

*Hong Kong Exchanges and Clearing Limited and The Stock Exchange of Hong Kong Limited take no responsibility for the contents of this announcement, make no representation as to its accuracy or completeness and expressly disclaim any liability whatsoever for any loss howsoever arising from or in reliance upon the whole or any part of the contents of this announcement.*

*This announcement does not constitute an offer to sell or the solicitation of an offer to buy any securities in the United States or any other jurisdiction in which such offer, solicitation or sale would be unlawful prior to registration or qualification under the securities laws of any such jurisdiction. The securities referred to herein will not be registered under the United States Securities Act of 1933, as amended (the “**Securities Act**”), and may not be offered or sold in the United States except pursuant to an exemption from, or a transaction not subject to, the registration requirements of the Securities Act. Any public offering of securities to be made in the United States will be made by means of a prospectus. Such prospectus will contain detailed information about the company making the offer and its management and financial statements. The Company does not intend to make any public offering of securities in the United States.*

花 樣 年

FANTASIA

**Fantasia Holdings Group Co., Limited**

**花樣年控股集團有限公司**

*(Incorporated in the Cayman Islands with limited liability)*

**(Stock Code: 01777)**

## **OVERSEAS REGULATORY ANNOUNCEMENT**

This overseas regulatory announcement is issued pursuant to Rule 13.10B of the Rules Governing the Listing of Securities (the “**Listing Rules**”) on The Stock Exchange of Hong Kong Limited (the “**Stock Exchange**”).

Reference is made to the announcements of Fantasia Holdings Group Co., Limited (the “**Company**”) dated May 20, 2013 and May 21, 2013 in relation to the Notes Issue (the “**Announcements**”). All terms used herein have the same meaning as defined in the Announcements, unless otherwise defined.

Please refer to the attached offering memorandum dated May 20, 2013 in relation to the Notes Issue (the “**Offering Memorandum**”), which was published on the website of Singapore Exchange Securities Trading Limited on May 28, 2013.

The posting of the Offering Memorandum on the website of the Stock Exchange is only for the purpose of facilitating equal dissemination of information to investors in Hong Kong and compliance with Rule 13.10B of the Listing Rules, and not for any other purposes.

The Offering Memorandum does not constitute a prospectus, notice, circular, brochure or advertisement offering to sell any securities to the public in any jurisdiction, nor is it an invitation to the public to make offers to subscribe for or purchase any securities, nor is it calculated to invite offers by the public to subscribe for or purchase any securities.

The Offering Memorandum must not be regarded as an inducement to subscribe for or purchase any securities of the Company, and no such inducement is intended. No investment decision should be based on the information contained in the Offering Memorandum.

By order of the Board  
**Fantasia Holdings Group Co., Limited**  
**Pan Jun**  
*Chairman*

Hong Kong, May 29, 2013

*As at the date of this announcement, the executive directors of the Company are Mr. Pan Jun, Ms. Zeng Jie, Baby, Mr. Lam Kam Tong and Mr. Zhou Jin Quan; the independent non-executive directors of the Company are Mr. Ho Man, Mr. Liao Martin Cheung Kong, JP, Mr. Huang Ming and Mr. Xu Quan.*

**IMPORTANT NOTICE  
NOT FOR DISTRIBUTION IN THE UNITED STATES**

**You must read the following disclaimer before continuing.** The following disclaimer applies to the document following this page and you are therefore advised to read this disclaimer carefully before accessing, reading or making any other use of the attached document. In accessing the attached document, you agree to be bound by the following terms and conditions, including any modifications to them from time to time, each time you receive any information from us as a result of such access.

**You acknowledge that the attached document and the information contained therein are strictly confidential and intended for you only.** You are not authorized to and you may not forward or deliver the attached document, electronically or otherwise, to any other person or reproduce such document in any manner whatsoever, nor may you disclose the information contained in the attached document to any third-party or use it for any other purpose. **Any forwarding, distribution, publication or reproduction of the attached document in whole or in part or disclosure of any information contained therein or any use of such information for any other purpose is unauthorized.** Failure to comply with this directive may result in a violation of the securities laws of applicable jurisdictions.

Nothing in this electronic transmission constitutes an offer to sell or a solicitation of an offer to buy any securities in any jurisdiction where it is unlawful to do so. The securities referred to in the attached document have not been and will not be registered under the U.S. Securities Act of 1933, as amended (the "U.S. Securities Act"), or under any securities laws of any state or other jurisdiction of the United States, and may not be offered, sold, resold, transferred or delivered, directly or indirectly, within the United States except pursuant to an applicable exemption from the registration requirements of the U.S. Securities Act and in compliance with any applicable securities laws of any state or other jurisdiction of the United States.

This document is not a prospectus for the purposes of the European Union's Directive 2003/71/EC (and any amendments thereto) as implemented in member states of the European Economic Area (the "EU Prospectus Directive"). This document has been prepared on the basis that all offers of the securities made to persons in the European Economic Area will be made pursuant to an exemption under the EU Prospectus Directive from the requirement to produce a prospectus in connection with offers of the securities.

**CONFIRMATION OF YOUR REPRESENTATION:** IN ORDER TO BE ELIGIBLE TO VIEW THE ATTACHED DOCUMENT, INVESTORS MUST COMPLY WITH THE FOLLOWING PROVISIONS. YOU HAVE BEEN SENT THE ATTACHED DOCUMENT ON THE BASIS THAT YOU HAVE CONFIRMED TO MERRILL LYNCH INTERNATIONAL, CITIGROUP GLOBAL MARKETS LIMITED, THE HONGKONG AND SHANGHAI BANKING CORPORATION LIMITED AND CHINA MERCHANTS SECURITIES (HK) CO., LIMITED (COLLECTIVELY THE "INITIAL PURCHASERS") THAT YOU (I) ARE OUTSIDE THE UNITED STATES, AND, TO THE EXTENT YOU PURCHASE THE SECURITIES DESCRIBED IN THE ATTACHED DOCUMENT, YOU WILL BE DOING SO IN AN OFFSHORE TRANSACTION, AS DEFINED IN REGULATIONS UNDER THE U.S. SECURITIES ACT ("REGULATION S"), IN COMPLIANCE WITH REGULATION S; AND (II) CONSENT TO DELIVERY BY ELECTRONIC TRANSMISSION.

If you have gained access to this transmission contrary to the foregoing restrictions, you will be unable to purchase any of the securities described therein.

This document has been made available to you in electronic form. You are reminded that documents transmitted via this medium may be altered or changed during the process of transmission and consequently none of the Initial Purchasers or any person who controls them or any of their respective directors, employees, representation or affiliates accepts any liability or responsibility whatsoever in respect of any difference between the document distributed to you in electronic format and the hard copy version.

You are responsible for protecting against viruses and other destructive items. Your receipt of this electronic transmission is at your own risk and it is your responsibility to take precautions to ensure that it is free from viruses and other items of a destructive nature.



FANTASIA

**FANTASIA HOLDINGS GROUP CO., LIMITED**

*(incorporated in the Cayman Islands with limited liability)*

**CNY1,000,000,000**

**7.875% Senior Notes due 2016**

**Issue Price: 100%**

Our 7.875% Senior Notes due 2016 (the “Notes”) will bear interest from May 27, 2013 at 7.875% per annum payable semi-annually in arrears on the business day on or nearest to May 27 and November 27 of each year, beginning November 27, 2013. The Notes will mature on the interest payment date on or nearest to May 27, 2016.

The Notes are senior obligations of Fantasia Holdings Group Co., Limited (the “Company”), guaranteed by certain of our existing subsidiaries (the “Subsidiary Guarantors”), other than (1) those organized under the laws of the PRC and (2) certain other subsidiaries specified in the section entitled “Description of the Notes.” We refer to the guarantees by the Subsidiary Guarantors as Subsidiary Guarantees. Under certain circumstances and subject to certain conditions, a Subsidiary Guarantee required to be provided by a subsidiary of the Company may be replaced by a limited-recourse guarantee (the “JV Subsidiary Guarantee”). We refer to the subsidiaries providing a JV Subsidiary Guarantee as JV Subsidiary Guarantors.

At any time prior to maturity, we may at our option redeem the Notes, in whole but not in part, at a redemption price equal to 100% of the principal amount of the Notes plus a premium (as set out in the section entitled “Description of the Notes” of this offering memorandum) as of, and accrued and unpaid interest, if any, to (but not including) the redemption date. At any time and from time to time prior to maturity, we may redeem up to 35% of the Notes, at a redemption price of 107.875% of the principal amount of the Notes, plus accrued and unpaid interest, if any, to (but not including) the redemption date, with the net cash proceeds from sales of certain kinds of capital stock of the Company. Upon the occurrence of a Change of Control Triggering Event (as defined in the indenture governing the Notes (the “Indenture”)), we must make an offer to repurchase all Notes outstanding at a purchase price equal to 101% of their principal amount, plus accrued and unpaid interest, if any, to the date of repurchase.

The Notes will be (1) senior in right of payment to any existing and future obligations of the Company expressly subordinated in right of payment to the Notes, (2) at least *pari passu* in right of payment against the Company with all other unsecured, unsubordinated indebtedness of the Company (subject to any priority rights of such unsubordinated indebtedness pursuant to applicable law), (3) effectively subordinated to the other secured obligations (if any) of the Company, the Subsidiary Guarantors and the JV Subsidiary Guarantors, to the extent of the value of the assets serving as security therefor (other than the collateral securing the Notes), and (4) effectively subordinated to all existing and future obligations of the Non-Guarantor Subsidiaries (as defined below). In addition, applicable law may limit the enforceability of the Subsidiary Guarantees and the JV Subsidiary Guarantees (if any) and the pledge of any collateral. See “Risk Factors — Risks Relating to the Subsidiary Guarantees, the JV Subsidiary Guarantees and the Collateral.”

For a more detailed description of the Notes, see the section entitled “Description of the Notes.”

**Investing in the Notes involves risks. See the section entitled “Risk Factors” beginning on page 19.**

Approval in-principle has been received for the listing and quotation of the Notes on the Official List of the Singapore Exchange Securities Trading Limited (the “SGX-ST”). The SGX-ST assumes no responsibility for the correctness of any of the statements made or opinions expressed or reports contained herein. Admission to the Official List of the SGX-ST and quotation of any Notes on the SGX-ST is not to be taken as an indication of the merits of the Company, the Subsidiary Guarantors, the JV Subsidiary Guarantors (if any) or any other subsidiary or associated company of the Company, the Notes, the Subsidiary Guarantees or the JV Subsidiary Guarantees. The Notes will be traded on the SGX-ST in a minimum board lot size of CNY200,000 with a minimum of six lots to be traded in a single transaction for so long as the Notes are listed on the SGX-ST and the rules of the SGX-ST so require.

The Notes, the Subsidiary Guarantees and the JV Subsidiary Guarantees (if any) have not been and will not be registered under the United States Securities Act of 1933, as amended (the “U.S. Securities Act”), and may not be offered or sold within the United States except pursuant to an exemption from, or in a transaction not subject to, the registration requirements of the U.S. Securities Act. The Notes are being offered and sold by the Initial Purchasers only outside the United States in offshore transactions in reliance on Regulation S under the U.S. Securities Act (“Regulation S”). For a description of certain restrictions on resale or transfer, see the section entitled “Transfer Restrictions.”

It is expected that the delivery of the Notes will be made on or about May 27, 2013 through the book-entry facilities of the Central Moneymarkets Unit Service (the “CMU”), the book-entry clearing system operated by the Hong Kong Monetary Authority (“HKMA”).

*Joint Lead Managers and Joint Bookrunners*

**BofA Merrill Lynch   Citigroup   HSBC   China Merchants Securities (HK)**

The date of this offering memorandum is May 20, 2013

## TABLE OF CONTENTS

SUMMARY .....	1	BUSINESS .....	108
THE OFFERING .....	6	REGULATION .....	146
SUMMARY CONSOLIDATED		MANAGEMENT .....	183
FINANCIAL AND OTHER DATA .....	13	PRINCIPAL SHAREHOLDERS .....	191
RISK FACTORS .....	19	RELATED PARTY TRANSACTIONS .....	192
USE OF PROCEEDS .....	57	DESCRIPTION OF MATERIAL	
EXCHANGE RATE INFORMATION .....	58	INDEBTEDNESS AND OTHER	
CAPITALIZATION AND		OBLIGATIONS .....	193
INDEBTEDNESS .....	60	DESCRIPTION OF THE NOTES .....	201
SELECTED CONSOLIDATED		TAXATION .....	266
FINANCIAL AND OTHER DATA .....	61	PLAN OF DISTRIBUTION .....	268
MANAGEMENT'S DISCUSSION AND		TRANSFER RESTRICTIONS .....	272
ANALYSIS OF FINANCIAL		RATINGS .....	274
CONDITION AND RESULTS OF		LEGAL MATTERS .....	274
OPERATIONS .....	67	INDEPENDENT ACCOUNTANTS .....	274
INDUSTRY OVERVIEW .....	93	GENERAL INFORMATION .....	275
CORPORATE STRUCTURE .....	104	INDEX TO FINANCIAL STATEMENTS ..	F-1

---

**This offering memorandum does not constitute an offer to sell to, or a solicitation of an offer to buy from, any person in any jurisdiction to whom it is unlawful to make the offer or solicitation in such jurisdiction. Neither the delivery of this offering memorandum nor any sale made hereunder shall, under any circumstances, create any implication that there has been no change in our affairs since the date of this offering memorandum or that the information contained in this offering memorandum is correct as of any time after that date.**

**This offering memorandum is not a prospectus for the purposes of the European Union's Directive 2003/71/EC (and any amendments thereto) as implemented in member states of the European Economic Area (the "EU Prospectus Directive"). This offering memorandum has been prepared on the basis that all offers of the Notes made to persons in the European Economic Area will be made pursuant to an exemption under the EU Prospectus Directive from the requirement to produce a prospectus in connection with offers of the Notes.**

**IN CONNECTION WITH THIS OFFERING, THE HONGKONG AND SHANGHAI BANKING CORPORATION LIMITED, AS STABILIZING MANAGER, OR ANY PERSON ACTING FOR IT, MAY PURCHASE AND SELL THE NOTES IN THE OPEN MARKET. THESE TRANSACTIONS MAY, TO THE EXTENT PERMITTED BY APPLICABLE LAWS AND REGULATIONS, INCLUDE SHORT SALES, STABILIZING TRANSACTIONS AND PURCHASES TO COVER POSITIONS CREATED BY SHORT SALES. THESE ACTIVITIES MAY STABILIZE, MAINTAIN OR OTHERWISE AFFECT THE MARKET PRICE OF THE NOTES. AS A RESULT, THE PRICE OF THE NOTES MAY BE HIGHER THAN THE PRICE THAT OTHERWISE MIGHT EXIST IN THE OPEN MARKET. IF THESE ACTIVITIES ARE COMMENCED, THEY MAY BE DISCONTINUED AT ANY TIME AND MUST IN ANY EVENT BE BROUGHT TO AN END AFTER A LIMITED TIME. THESE ACTIVITIES WILL BE UNDERTAKEN SOLELY FOR THE ACCOUNT OF THE INITIAL PURCHASERS, AND NOT FOR US OR ON OUR BEHALF.**

We, having made all reasonable inquiries, confirm that: (i) this offering memorandum contains all information with respect to us, our subsidiaries and affiliates referred to in this offering memorandum and the Notes, the Subsidiary Guarantees and the JV Subsidiary Guarantees (if any) that is material in the context of the issue and offering of the Notes; (ii) the statements contained in this offering memorandum relating to us and our subsidiaries and our affiliates are in every material respect true and accurate and not misleading; (iii) the opinions and intentions expressed in this offering memorandum with regard to us and our subsidiaries and affiliates are honestly held, have been reached after considering all relevant circumstances and are based on reasonable assumptions; (iv) there are no other facts in relation to us, our subsidiaries and affiliates, the Notes, the Subsidiary Guarantees and the JV Subsidiary Guarantees (if

any), the omission of which would, in the context of the issue and offering of the Notes, make this offering memorandum, as a whole, misleading in any material respect; and (v) we have made all reasonable enquiries to ascertain such facts and to verify the accuracy of all such information and statements. We accept responsibility accordingly.

This offering memorandum is highly confidential. We are providing it solely for the purpose of enabling you to consider a purchase of the Notes. You should read this offering memorandum before making a decision whether to purchase the Notes. You must not use this offering memorandum for any other purpose, or disclose any information in this offering memorandum to any other person.

We have prepared this offering memorandum, and we are solely responsible for its contents. You are responsible for making your own examination of us and your own assessment of the merits and risks of investing in the Notes. By purchasing the Notes, you will be deemed to have acknowledged that you have made certain acknowledgements, representations and agreements as set forth under the section entitled “Transfer Restrictions” below.

No representation or warranty, express or implied, is made by Merrill Lynch International, Citigroup Global Markets Limited, The Hongkong and Shanghai Banking Corporation Limited and China Merchants Securities (HK) Co., Limited (the “Initial Purchasers”) or any of their respective affiliates or advisors as to the accuracy or completeness of the information set forth herein, and nothing contained in this offering memorandum is, or should be relied upon as, a promise or representation, whether as to the past or the future.

Each person receiving this offering memorandum acknowledges that: (i) such person has been afforded an opportunity to request from us and to review, and has received, all additional information considered by it to be necessary to verify the accuracy of, or to supplement, the information contained herein; (ii) such person has not relied on the Initial Purchasers or any person affiliated with the Initial Purchasers in connection with any investigation of the accuracy of such information or its investment decision; and (iii) no person has been authorized to give any information or to make any representation concerning us, our subsidiaries and affiliates, the Notes, the Subsidiary Guarantees or the JV Subsidiary Guarantees (other than as contained herein and information given by our duly authorized officers and employees in connection with investors’ examination of our company and the terms of the offering of the Notes) and, if given or made, any such other information or representation should not be relied upon as having been authorized by us or the Initial Purchasers.

**The Notes, the Subsidiary Guarantees and the JV Subsidiary Guarantees (if any) have not been approved or disapproved by the United States Securities and Exchange Commission (the “SEC”), any state securities commission in the United States or any other United States regulatory authority, nor have any of the foregoing authorities passed upon or endorsed the merits of the offering or the accuracy or adequacy of this offering memorandum. Any representation to the contrary is a criminal offense in the United States.**

We are not, and the Initial Purchasers are not, making an offer to sell the Notes, including the Subsidiary Guarantees and the JV Subsidiary Guarantees (if any), in any jurisdiction except where an offer or sale is permitted. The distribution of this offering memorandum and the offering of the securities, including the Notes, the Subsidiary Guarantees and the JV Subsidiary Guarantees (if any), may in certain jurisdictions be restricted by law. Persons into whose possession this offering memorandum comes are required by us and the Initial Purchasers to inform themselves about and to observe any such restrictions. For a description of the restrictions on offers, sales and resales of the securities, including the Notes, the Subsidiary Guarantees and the JV Subsidiary Guarantees (if any), and distribution of this offering memorandum, see the sections entitled “Transfer Restrictions” and “Plan of Distribution” below.

This offering memorandum summarizes certain material documents and other information, and we refer you to them for a more complete understanding of what we discuss in this offering memorandum. In making an investment decision, you must rely on your own examination of us and the terms of the offering, including the merits and risks involved. We are not making any representation to you regarding the legality of an investment in the Notes by you under any legal, investment or similar laws or regulations. You should not consider any information in this offering memorandum to be legal, business or tax advice. You should consult your own professional advisors for legal, business, tax and other advice regarding an investment in the Notes.

We reserve the right to withdraw the offering of Notes at any time, and the Initial Purchasers reserve the right to reject any commitment to subscribe for the Notes in whole or in part and to allot to any prospective purchaser less than the full amount of the Notes sought by such purchaser. The Initial Purchasers and certain related entities may acquire for their own account a portion of the Notes.

## **CERTAIN DEFINITIONS, CONVENTIONS AND CURRENCY PRESENTATION**

We have prepared this offering memorandum using a number of conventions, which you should consider when reading the information contained herein. When we use the terms “we,” “us,” “our,” the “Company,” the “Group” and words of similar import, we are referring to Fantasia Holdings Group Co., Limited itself, or Fantasia Holdings Group Co., Limited and its consolidated subsidiaries, as the context requires.

Market data, industry forecast and the PRC and property industry statistics in this offering memorandum have been obtained from both public and private sources, including market research, publicly available information and industry publications. Although we believe this information to be reliable, it has not been independently verified by us or the Initial Purchasers or our or their respective directors and advisors, and neither we, the Initial Purchasers nor our or their directors and advisors make any representation as to the accuracy or completeness of that information. In addition, third-party information providers may have obtained information from market participants and such information may not have been independently verified. Due to possibly inconsistent collection methods and other problems, such statistics herein may be inaccurate. You should not unduly rely on such market data, industry forecast and the PRC and property industry statistics.

In this offering memorandum, all references to “US\$” and “U.S. dollars” are to United States dollars, the official currency of the United States of America (the “United States” or “U.S.”); all references to “HK\$” and “H.K. dollars” are to Hong Kong dollars, the official currency of the Hong Kong Special Administrative Region of the PRC (“Hong Kong” or “HK”); and all references to “RMB” or “Renminbi” are to Renminbi, the official currency of the People’s Republic of China (“China” or the “PRC”).

We record and publish our financial statements in Renminbi. Unless otherwise stated in this offering memorandum, all translations from Renminbi amounts to U.S. dollars were made at the rate of RMB6.2301 to US\$1.00, the noon buying rate in New York City for cable transfers payable in Renminbi as certified for customs purposes by the Federal Reserve Bank of New York on December 31, 2012, and all translations from H.K. dollars into U.S. dollars were made at the rate of HK\$7.7507 to US\$1.00, the noon buying rate in New York City for cable transfers payable in H.K. dollars as certified for customs purposes by the Federal Reserve Bank of New York on December 31, 2012. All such translations in this offering memorandum are provided solely for your convenience and no representation is made that the Renminbi amounts referred to herein have been, could have been or could be converted into U.S. dollars or H.K. dollars, or vice versa, at any particular rate or at all. For further information relating to the exchange rates, see the section entitled “Exchange Rate Information.”

References to “PRC” and “China,” in the context of statistical information and description of laws and regulations in this offering memorandum, except where the context otherwise requires, do not include Hong Kong, Macau Special Administrative Region of the PRC (“Macau”), or Taiwan. “PRC government” or “State” means the central government of the PRC, including all political subdivisions (including provincial, municipal and other regional or local governments) and instrumentalities thereof, or, where the context requires, any of them.

Our financial statements are prepared in accordance with Hong Kong Financial Reporting Standards (the “HKFRS”) which differ in certain respects from generally accepted accounting principles in certain other countries.

Unless the context otherwise requires, references to “2010,” “2011” and “2012” in this offering memorandum are to our financial years ended December 31, 2010, 2011 and 2012, respectively.

References to the “2010 Notes” are to our 14% Senior Notes due 2015.

References to the “2012 Notes” are to our 13.75% Senior Notes due 2017.

References to the “January 2013 Notes” are to our 10.75% Senior Notes due 2020.

References to “share” are to, unless the context indicates otherwise, an ordinary share, with a nominal value of HK\$0.1, in our share capital.

A property is considered sold after we have executed the purchase contract with a customer and have delivered the property to the customer. All site area and gross floor area (“GFA”) information presented in this offering memorandum represent the site area and GFA of the entire project, including those attributable to the minority shareholders of our non-wholly owned project companies.

In this offering memorandum, unless the context otherwise requires, all references to “affiliate” are to person or entity directly or indirectly controlled by, or under the direct or indirect common control of, another person or entity; all references to “subsidiary” are used with the meaning ascribed to it in the Rules Governing the Listing of Securities on the Hong Kong Stock Exchange, as amended (the “Listing Rules”), which includes: (i) a “subsidiary undertaking” as defined in the twenty-third schedule to the Companies Ordinance (Chapter 32 of the Laws of Hong Kong) (the “Companies Ordinance”), (ii) any entity which is accounted for and consolidated in the audited consolidated accounts of another entity as a subsidiary pursuant to HKFRS or International Financial Reporting Standards, as applicable, and (iii) any entity which will, as a result of acquisition of its equity interest by another entity, be accounted for and consolidated in the next audited consolidated accounts of such other entity as a subsidiary pursuant to HKFRS or International Financial Reporting Standards, as applicable; all references to “associate” are used with the meaning ascribed thereto under the Listing Rules, which includes: (i) in relation to an individual, his spouse and children under the age of 18, certain trustees, his or his family holding companies, as well as companies over which he, his family, trustee interests and holding companies exercise at least 30% voting power, (ii) in relation to a company, its subsidiaries, its holding companies, subsidiaries of such holding companies, certain trustees, as well as companies over which such company and its subsidiaries, trustee interests, holding companies and subsidiaries of such holding companies together exercise at least 30% voting power and (iii) in the context of connected transactions, certain connected persons and enlarged family members of a director, chief executive or substantial shareholder of a listed issuer; and all references to “controlling shareholder” are used with the meaning ascribed thereto under the Listing Rules, including any person or group of persons who are entitled to exercise 30% or more of the voting power at our general meetings or are in a position to control the composition of a majority of our board of directors, and “controlling interest” will be construed accordingly.

In this offering memorandum, a land grant contract refers to a state-owned land use rights grant contract (國有土地使用權出讓合同) between a developer and the relevant PRC governmental land administrative authorities, typically the local state-owned land bureaus.

In this offering memorandum, a land use rights certificate refers to a state-owned land use rights certificate (國有土地使用權證) issued by a local real estate and land resources bureau with respect to the land use rights; a construction land planning permit refers to a construction land planning permit (建設用地規劃許可證) issued by local urban zoning and planning bureaus or equivalent authorities in China; a construction works planning permit refers to a construction works planning permit (建設工程規劃許可證) issued by local urban zoning and planning bureaus or equivalent authorities in China; a construction permit refers to a construction works commencement permit (建築工程施工許可證) issued by local construction committees or equivalent authorities in China; a pre-sale permit refers to a commodity property pre-sale permit (商品房預售許可證) issued by local housing and building administrative bureaus or equivalent authorities with respect to the pre-sale of relevant properties; a certificate of completion refers to a construction project planning inspection and clearance certificate (建設工程規劃驗收合格證) issued by local urban zoning and planning bureaus or equivalent authorities or equivalent certificate issued by relevant authorities in China with respect to the completion of property projects subsequent to their on-site examination and inspection; and a property ownership certificate refers to a property ownership and land use rights certificate (國有土地使用權證) issued by a local real estate and land resources bureau with respect to the land use rights and the ownership rights of the buildings on the relevant land.

In this offering memorandum, where information has been presented in thousands or millions of units, amounts may have been rounded up or down. Accordingly, totals of columns or rows of numbers in tables may not be equal to the apparent total of the individual items and actual numbers may differ from those contained herein due to such rounding.

The English names of the PRC nationals, entities, departments, facilities, laws, regulations, certificates, titles and the like are translations of their Chinese names and are included for identification purposes only. In the event of any inconsistency, the Chinese name prevails.



## FORWARD-LOOKING STATEMENTS

This offering memorandum contains forward-looking statements that are, by their nature, subject to significant risks and uncertainties. These forward-looking statements include statements relating to:

- our business and operating strategies;
- our capital expenditure and property development plans;
- the amount and nature of, and potential for, future development of our business;
- our operations and business prospects;
- various business opportunities that we may pursue;
- the interpretation and implementation of the existing rules and regulations relating to land appreciation tax and its future changes in enactment, interpretation or enforcement;
- the prospective financial information regarding our businesses;
- availability and costs of bank loans and other forms of financing;
- our dividend policy;
- projects under development or held for future development;
- the regulatory environment of our industry in general;
- the performance and future developments of the property market in China or any region in China in which we may engage in property development;
- changes in political, economic, legal and social conditions in China, including the specific policies of the PRC central and local governments affecting the regions where we operate, which affect land supply, availability and cost of financing, and pre-sale, pricing and volume of our property development projects;
- significant delay in obtaining the various permits, proper legal titles or approvals for our properties under development or held for future development;
- timely repayments by our purchasers of mortgage loans guaranteed by us;
- changes in competitive conditions and our ability to compete under these conditions;
- the performance of the obligations and undertakings of the third-party contractors under various construction, building, interior decoration, material and equipment supply and installation contracts;
- changes in currency exchange rates; and
- other factors beyond our control.

In some cases, you can identify forward-looking statements by such terminology as “may,” “will,” “should,” “could,” “would,” “expect,” “intend,” “plan,” “anticipate,” “going forward,” “ought to,” “seek,” “project,” “forecast,” “believe,” “estimate,” “predict,” “potential” or “continue” or the negative of these terms or other comparable terminology. Such statements reflect the current views of our management with respect to future events, operations, results, liquidity and capital resources and are not guarantee of future performance and some of which may not materialize or may change. Although we believe that the

expectations reflected in these forward-looking statements are reasonable, we cannot assure you that those expectations will prove to be correct, and you are cautioned not to place undue reliance on such statements. In addition, unanticipated events may adversely affect the actual results we achieve. Important factors that could cause actual results to differ materially from our expectations are disclosed under the section entitled “Risk Factors” in this offering memorandum. Except as required by law, we undertake no obligation to update or otherwise revise any forward-looking statements contained in this offering memorandum, whether as a result of new information, future events or otherwise after the date of this offering memorandum. All forward-looking statements contained in this offering memorandum are qualified by reference to the cautionary statements set forth in this section.

## SUMMARY

*This summary does not contain all the information that may be important to you in deciding to invest in the Notes. You should read the entire offering memorandum, including the section entitled “Risk Factors” and our consolidated financial statements and related notes thereto, before making an investment decision.*

### Overview

We are a leading property developer and property related service provider in China. For four consecutive years from 2009 to 2012, we have members of our Group ranked among the China Top 100 Real Estate Developers (中國房地產百強企業) and the China Top 100 Property Management Companies (中國物業服務百強企業) by the China Real Estate Top 10 Research Team (中國房地產Top 10研究組). We were also ranked among the China Real Estate Top 100 Listed Companies (中國房地產上市公司百強) in 2011 and the Top 50 China Real Estate Listed Companies in terms of Comprehensive Strength (中國房地產上市公司綜合實力五十強) in 2011 and 2012 by the China Real Estate Research Institute, China Real Estate Association and China Real Estate Assessment Center. We first commenced our property development business in Shenzhen in 1996. Leveraging on our broad experience and capabilities, we have successfully expanded into, and currently focus our real estate activities in, four of the fastest-growing economic regions in China, including the Chengdu-Chongqing Economic Zone, the Pearl River Delta region, the Yangtze River Delta region and the Beijing-Tianjin metropolitan region.

Our target customers are affluent middle- to upper-class individuals and families and fast growing small- to medium-sized enterprises. We envisage that the demand for properties designed for these customers will increase as such customers' household income and purchasing power continue to rise. To cater to the diverse needs of our target customers, we have developed a portfolio of property development projects with a focus on the following:

- *Urban Complexes*

Our urban complexes are mostly located in the peripheral areas of existing central business districts in major cities such as Shenzhen and Chengdu or in the emerging new business districts designated under city development plans of local governments. These complexes integrate various types of properties, such as offices, apartments, retail shops and/or boutique hotels, into a single property development project. For example, our urban complex Chengdu Hailun Plaza (成都喜年廣場), which has received several awards, is one of the tallest buildings and a local landmark in Chengdu, and we believe our Chengdu MIC Plaza (formerly known as Chengdu Meinian International Plaza, 成都美年國際廣場) is one of the largest urban complexes currently under development in Chengdu.

- *Boutique Upscale Residences*

Our boutique upscale residences are located in urban and suburban areas with natural scenic surroundings or cultural landmarks. They are connected by roads or expressways to the centers of major metropolitan areas. These boutique upscale residences include high- and low-rise apartment buildings, townhouses and stand-alone houses and cater to the residential and investment needs of our high-end consumers. We typically develop our boutique upscale residential projects in several phases so that we can manage our capital resources more efficiently and increase the average selling price as the project becomes more developed and attractive to our customers. Examples of such boutique upscale residential projects include Grand Valley (大溪谷), a large scale residential complex in Pujiang County of Chengdu that is surrounded by natural sceneries, and Chengdu Belle Epoque (成都君山), a large scale residential community located in a famous tourist attraction in Xinjin County of Chengdu, Yixing Town on the Water (雲海間), adjacent to the Hengshan Reservoir in Jiangsu province, and Dongguan Mont Conquerant (東莞君山), adjacent to the Fengjing Golf Course.

As of December 31, 2012, our portfolio of land bank consisted of approximately 31% of boutique upscale residences, 36% of urban complexes and 33% of mid-to-high end residences in terms of GFA. We

plan to continue to focus our property development activities on developing a portfolio of products that caters to our target customers across four of China's most economically prosperous regions. We plan to achieve this objective by continuing to selectively acquire low-cost land in the four regions. We conduct comprehensive and in-depth market research and analysis on the land that we intend to acquire and the surrounding areas. We consider the geographic as well as marketing factors when evaluating a target parcel, including development potentials, size and suitability of the land for developments that can fit into our existing portfolio, convenience and availability of infrastructure support, purchasing power of our potential customers in relevant areas, development costs and the estimated return on investment. We budget for the cost of land acquisition as well as the overall development costs, which are subject to strict internal procedures and are closely monitored and adjusted throughout the construction process. Acquisition proposal is reviewed and approved by the relevant personnel of our Group, including our chief executive officer and our board of directors. We usually acquire land using our own capital within a pre-set budget and arrange project loans with banks in China at a later stage to support the subsequent development of the property.

In addition to our property development business, we also provide property operation services, property agency services and hotel services to our own properties and properties of third parties. In February 2011, we disposed of our entire 85% equity interests in Shenzhen Xingyan Property Consultancy Company Limited (深圳市星彥地產顧問有限公司), our subsidiary engaged in the provision of property agency services, to concentrate on our main business, but we still maintain secondary property brokerage services as a value-added service in the property operation services business. We believe our property related services enable us to strengthen our property development capabilities. For example, our property operation services enhance the value of our properties. We plan to continue to enhance such real estate services that we offer and to further enhance the intrinsic synergies between our real estate products and services. We will in particular focus on enhancing our property operation services and hotel services which we believe will serve as relatively stable and growing revenue sources to our Group on the one hand, and will continue to increase the attractiveness and the average selling price of the properties developed by us on the other.

We have received numerous accolades for our property development and services capabilities. For example, our subsidiary, Fantasia (Chengdu) Development Co., Ltd. was awarded one of the real estate industry's highest honorary award "Golden Tripod" — 2009 outstanding development Business Awards ("金鼎獎" — 2009年度優秀開發企業獎) jointly issued by Chengdu Municipal Government (成都市政府) and the Chengdu Real Estate Bureau (成都房地產管理局) in 2010. Another subsidiary, Shenzhen Colour Life Services Group Company Limited, was awarded "Top 10 Growth Enterprises in Top 100 Property Services Companies in China in 2012" (2012中國物業服務百強企業成長性TOP 10) and "China Top 100 Property Services Companies" (中國物業服務百強企業) for four consecutive years from 2009 to 2012 by China Real Estate Top 10 Research Team (中國房地產TOP 10研究組) in June 2012. Our subsidiary, Shenzhen Colour Life Services Group Company Limited was awarded "2012 China Property Services Enterprise of Brand Excellence" (2012中國物業服務優秀品牌企業) by China Index Research Institute in August 2012. We were also awarded "2012 China Best Commercial Real Estate Brand" (2012中國最佳商業地產品牌) by Organizing Committee of Boao Real Estate Forum (博鰲房地產論壇委員會) in August 2012, and was listed on both "List of Top 100 Outstanding Real Estate Enterprises in China for 2012" (2012年度中國房地產卓越100榜) and "List of China's Outstanding Real Estate Management and Real Estate Teams in China for 2012" (2012年度中國房地產管理與團隊卓越榜) by guandian.cn (觀點地產新媒體). Our property development projects have also won numerous awards and recognitions for their design and quality. For example, our project Shenzhen Meinian International Complex (深圳美年國際廣場) was awarded "China Real Estate Index System: The Best Business Complex of Garden Style in South China in 2010" (2010 中國房地產指數系統華南最佳園林式商務綜合體) by China Real Estate Association (中國房地產協會) and China Index Research Institute (中國指數研究院) in 2010. Tianjin Hailun Plaza (天津喜年廣場) was awarded "Structural HaiHe Cup" (結構海河杯) by Tianjin Construction Association (天津市建築業協會) in 2010. Dongguan Mont Conquerant (東莞君山) was awarded "China Real Estate Index System: Top Ten Distinctive Villa Models in 2010 — Villa in the Air" (2010中國房地產指數系統十大特色典範別墅—空中別墅) by China Index Research Institute (中國指數研究院) in 2010. Chengdu Hailun Plaza (成都喜年廣場) was awarded "2010 – 2011 Silver Medal of the State Outstanding Construction Projects" (2010年–2011年度國家優質工程銀獎) organized by China Construction Industry Association (中國建築業協會) in 2011. Guilin Fantasia Town was awarded "Real Estate with the Most Potential in Value in 2011" (2011年最具價值潛力樓盤) by the Fourth Session of Guilin Spring Brand Real Estate Fair (桂林第四屆春季品牌房地產交易會) in 2011. Shenzhen Funian Plaza was awarded "Grand Prize for Commercial Real Estate for 2012" (2012年度商業地產大獎) by 21st Century Business Herald (《21世紀經濟報導》) and Golden Brick Award Selection Committee for Real

Estate of China (中國地產金磚獎評選委員會) in July 2012. It was further awarded “Grand Prize of Office Building of the Year at the 2012 China’s Real Estate Annual Meeting” (2012中國地產年會年度寫字樓大獎) by Nanfang City News (《南方都市報》). Nanjing Yuhuatai Project was awarded “The Best Commercial Real Estate in Nanjing, China for 2012” (2012中國(南京)最佳商業地產) by Yangtze Evening News (《揚子晚報》).

As of December 31, 2012, we had a total of 40 projects at various stages of development (including completed projects, projects under development and projects held for future development), including 14 projects located in the Chengdu-Chongqing Economic Zone, 13 projects located in the Pearl River Delta region, eight projects located in the Yangtze River Delta region and five projects located in the Beijing-Tianjin metropolitan region.

As of December 31, 2012, we had a total land bank of approximately 11,714,530 square meters, which consist of:

- an aggregate planned GFA of approximately 8,025,896 square meters of properties for which we had fully paid the land premium and obtained land use rights (consisting of an aggregate planned GFA of approximately 2,672,213 square meters of properties under development and an aggregate planned GFA of approximately 5,353,683 square meters of properties held for future development for which we have obtained land use rights); and
- an aggregate planned GFA of approximately 3,688,634 square meters of properties for which we had entered into preliminary framework agreements but had not obtained the land use rights or property rights.

Of our total land bank as of December 31, 2012, approximately 6,645,173 square meters, or 56.7%, were located in the Chengdu-Chongqing Economic Zone; approximately 3,317,137 square meters, or 28.3%, were located in the Pearl River Delta region; approximately 901,562 square meters, or 7.7%, were located in the Yangtze River Delta region; and approximately 850,658 square meters, or 7.3%, were located in the Beijing-Tianjin metropolitan region. We develop most of our properties, including properties that are currently under development, for sale but will hold certain of these developed properties for investment and hotel management purposes.

For each of the years ended December 31, 2010, 2011 and 2012, our revenue was RMB4,471.2 million, RMB5,592.4 million and RMB6,230.1 million (US\$1,000.0 million), respectively. Our revenue for the three years ended December 31, 2010, 2011 and 2012 consisted of revenue derived from (i) the sales of our developed properties, (ii) the lease of investment properties, (iii) the provision of property agency and related services, (iv) the provision of property operation and related services, and (v) the provision of hotel management and related services. The following table sets forth our revenue for each of the components described above and the percentage of total revenue represented for the years indicated with the fluctuations of the percentage due primarily to the different product mix delivered to customers in respective period:

	For the year ended December 31,						
	2010		2011		2012		
	RMB	%	RMB	%	RMB	US\$	%
	(unaudited)						
	(in thousands, except percentages)						
Property development . . . . .	4,320,413	96.6	5,396,289	96.5	5,885,314	944,658	94.5
Property investment . . . . .	17,727	0.4	37,887	0.7	90,266	14,489	1.4
Property agency services . . . . .	36,845	0.8	10,571	0.2	14,470	2,322	0.2
Property operation services . . . . .	89,228	2.0	124,895	2.2	184,683	29,644	3.0
Hotel services . . . . .	7,021	0.2	22,708	0.4	55,317	8,879	0.9
Total . . . . .	4,471,234	100.0	5,592,350	100.0	6,230,050	999,992	100.0

## Recent Developments

Subsequent to December 31, 2012, we entered into certain framework agreements and formal agreements in relation to acquisition of parcels of land as set forth in the table below:

Date of framework agreement/ Time of Acquisition	Location	Attributable interest	Site area (square meters)	Planned total GFA (square meters)	Consideration (RMB in millions)	Type
February 2013 . . . . .	Wenjiang, Chengdu	100%	73,394	293,588	213.00	Residential and commercial
February 2013 . . . . .	Shenzhen	100%	43,236	117,000	95.80	Industrial offices
March 2013 . . . . .	Suzhou	100%	73,059	199,865	511.00	Residential and commercial
March 2013 . . . . .	Singapore	90%	13,023	14,500	754.00	Residential
March 2013 . . . . .	Dongguan	100%	14,306	33,719	31.50	Residential
April 2013 . . . . .	Pixian, Chengdu	100%	40,381	175,249	199.88	Residential and commercial
May 2013 . . . . .	Shanghai	100%	N/A	17,563	282.50	Residential
Total . . . . .			<u>257,399</u>	<u>851,484</u>	<u>2,087.68</u>	

## Our Competitive Strengths

We believe that our primary competitive strengths are:

- property development portfolio strategically located across four of China's most economically prosperous regions;
- ability to acquire land at low cost;
- strong business model with track record of success;
- well-known brand name;
- strong value-accretion property development and service capabilities; and
- experienced and stable management team with proven track record supported by seasoned professional employees.

## Our Business Strategies

Our business strategies are to:

- continue to expand in fast-growing economic regions in China and selectively acquire low-cost land;
- focus on further improving the intrinsic synergies of our real estate products and value-added services;
- continue to improve our property operation service and hotel service capabilities to further increase the attractiveness and value of our properties; and
- continue to promote our brand names.

**General Information**

We were incorporated in the Cayman Islands on October 17, 2007, as an exempted company with limited liability. Our shares have been listed on the Stock Exchange of Hong Kong Limited since November 25, 2009. Our principal place of business in the PRC is at 27/F, Block A, Hailrun Complex, No. 6021 Shennan Boulevard, Shenzhen, Guangdong Province, China. Our place of business in Hong Kong is at Room 1103, Top Glory Tower, 262 Gloucester Road, Causeway Bay, Hong Kong. Our registered office is located at Cricket Square, Hutchins Drive, P.O. Box 2681, Grand Cayman, KY1-1111, Cayman Islands. Our website is *www.cnfantasia.com*. Information contained on our website does not constitute part of this offering memorandum.

## THE OFFERING

Terms used in this summary and not otherwise defined shall have the meanings given to them in “Description of the Notes.”

Issuer . . . . .	Fantasia Holdings Group Co., Limited (the “Company”).
Notes Offered . . . . .	CNY1,000,000,000 aggregate principal amount of 7.875% Senior Notes due 2016 (the “Notes”).
Offering Price . . . . .	100% of the principal amount of the Notes.
Maturity Date . . . . .	Interest payment date on or nearest to May 27, 2016.
Interest . . . . .	The Notes will bear interest from and including May 27, 2013 at the rate of 7.875% per annum, payable semi-annually in arrears.
Interest Payment Dates . . . . .	The business day on or nearest to May 27 and November 27 of each year, commencing November 27, 2013.
Ranking of the Notes . . . . .	The Notes are:

- general obligations of the Company;
- senior in right of payment to any existing and future obligations of the Company expressly subordinated in right of payment to the Notes;
- at least *pari passu* in right of payment with all other unsecured, unsubordinated Indebtedness of the Company (subject to any priority rights of such unsubordinated Indebtedness pursuant to applicable law);
- guaranteed by the Subsidiary Guarantors on a senior basis, subject to certain limitations described under “Risk Factors — Risks Relating to the Subsidiary Guarantees, the JV Subsidiary Guarantees and the Collateral” and “Description of the Notes — The Subsidiary Guarantees;”
- effectively subordinated to the other secured obligations (if any) of the Company, the Subsidiary Guarantors and the JV Subsidiary Guarantors, to the extent of the value of the assets serving as security therefor (other than the Collateral); and
- effectively subordinated to all existing and future obligations of the Non-Guarantor Subsidiaries.

After the pledge of the Collateral by the Company and the Subsidiary Guarantor Pledgors and subject to certain limitations described under “Risk Factors — Risks Relating to the Subsidiary Guarantees, the JV Subsidiary Guarantees and Collateral,” the Notes will:

- be entitled to the benefit of a lien on the Collateral pledged by the Company and the Subsidiary Guarantor Pledgors (subject to any Permitted Liens) shared on a *pari passu* basis pursuant to the Intercreditor Agreement among (i) holders of the 2010 Notes, (ii) holders of the 2012 Notes, (iii) holders of the January 2013 Notes, (iv) holders of the Notes and (v) holders of other Permitted *Pari Passu* Secured Indebtedness; and



- rank effectively senior in right of payment to unsecured obligations of the Company with respect to the value of the Collateral pledged by the Company securing the Notes (subject to any priority rights of such unsecured obligations pursuant to applicable law).

Subsidiary Guarantees . . . . . Each of the Subsidiary Guarantors will, jointly and severally, guarantee the due and punctual payment of the principal of, premium, if any, and interest on, and all other amounts payable under, the Notes.

The initial Subsidiary Guarantors will consist of all of the Restricted Subsidiaries other than (i) those Restricted Subsidiaries organized under the laws of the PRC and (ii) Talent Bright International Limited, Fantasia Property Management (International) Company Limited, Winning Sky International Limited and Hong Kong Kangnian Trading Co., Limited.

All of the initial Subsidiary Guarantors are holding companies that do not have significant operations. See “Risk Factors — Risks Relating to the Subsidiary Guarantees, the JV Subsidiary Guarantees and the Collateral — Our initial Subsidiary Guarantors do not currently have significant operations and certain Subsidiary Guarantees may in some cases be replaced by limited-recourse guarantees.”

Any future Restricted Subsidiary, as defined under “Description of the Notes — Certain Definitions” (other than subsidiaries organized under the laws of the PRC), will guarantee the Notes as either a Subsidiary Guarantor or a JV Subsidiary Guarantor promptly upon becoming a Restricted Subsidiary. Notwithstanding the foregoing, the Company may elect to have any future Restricted Subsidiary organized outside the PRC not provide a Subsidiary Guarantee or a JV Subsidiary Guarantee at the time such entity becomes a Restricted Subsidiary, *provided* that, after giving effect to the Consolidated Assets of such Restricted Subsidiary, the Consolidated Assets of all Restricted Subsidiaries organized outside the PRC that are not Subsidiary Guarantors or JV Subsidiary Guarantors do not account for more than 10% of the Total Assets of the Company.

A Subsidiary Guarantee may be released or replaced in certain circumstances. See “Description of the Notes — The Subsidiary Guarantees — Release of the Subsidiary Guarantees and JV Subsidiary Guarantees.” In the case of a Subsidiary Guarantor with respect to which the Company or any of its Restricted Subsidiaries is proposing to sell, whether through the sale of existing shares or the issuance of new shares, no less than 20% of the Capital Stock of such Subsidiary Guarantor, the Company may (i) release the Subsidiary Guarantees provided by such Subsidiary Guarantor and each of its Restricted Subsidiaries organized outside the PRC, (ii) discharge the pledge of the Capital Stock granted by such Subsidiary Guarantor, and (iii) discharge the pledge of Capital Stock made by the Company or any Subsidiary Guarantor over the shares it owns in such Subsidiary Guarantor, *provided* that after the release of such Subsidiary Guarantees, the Consolidated Assets of all Restricted Subsidiaries organized outside the PRC that are not Subsidiary Guarantors or JV Subsidiary Guarantors (including the Subsidiary Guarantors whose Subsidiary Guarantees were released) do not account for more than 10% of the Total Assets of the Company.

Ranking of Subsidiary Guarantees . . . . . The Subsidiary Guarantee of each Subsidiary Guarantor:

- is a general obligation of such Subsidiary Guarantor;
- is effectively subordinated to other secured obligations (if any) of such Subsidiary Guarantor, to the extent of the value of the assets serving as security therefor (other than the Collateral);
- is senior in right of payment to all future obligations of such Subsidiary Guarantor expressly subordinated in right of payment to such Subsidiary Guarantee; and
- ranks at least *pari passu* with all other unsecured, unsubordinated Indebtedness of such Subsidiary Guarantor (subject to any priority rights of such unsubordinated Indebtedness pursuant to applicable law).

After the pledge of the Collateral by the Company and the Subsidiary Guarantor Pledgors and subject to certain limitations described under “Risk Factors — Risks Relating to the Subsidiary Guarantees, the JV Subsidiary Guarantees and Collateral,” the Subsidiary Guarantees of each Subsidiary Guarantor Pledgor will:

- be entitled to the benefit of a security interest in the Collateral pledged by such Subsidiary Guarantor Pledgor (subject to any Permitted Liens) shared on a *pari passu* basis pursuant to the Intercreditor Agreement among (i) holders of the 2010 Notes, (ii) holders of the 2012 Notes, (iii) holders of the January 2013 Notes, (iv) holders of the Notes and (v) holders of other Permitted *Pari Passu* Secured Indebtedness; and

- rank effectively senior in right of payment to the unsecured obligations of such Subsidiary Guarantor Pledgor with respect to the value of the Collateral securing such Subsidiary Guarantee (subject to any priority rights of such unsecured obligations pursuant to applicable law).

Ranking of JV Subsidiary Guarantees . . . .

A JV Subsidiary Guarantee instead of a Subsidiary Guarantee may be provided by a Subsidiary Guarantor following a sale by the Company or any of its Restricted Subsidiaries of Capital Stock in such Subsidiary Guarantor, where such sale is for no less than 20% and no more than 49.9% of the issued Capital Stock of such Subsidiary Guarantor. No JV Subsidiary Guarantee exists as of the Original Issue Date.

The JV Subsidiary Guarantee of each JV Subsidiary Guarantor will:

- be a general obligation of such JV Subsidiary Guarantor;
- be enforceable only up to the JV Entitlement Amount;
- be effectively subordinated to secured obligations (if any) of such JV Subsidiary Guarantor, to the extent of the value of the assets serving as security therefor;
- be limited to the JV Entitlement Amount, and will be senior in right of payment to all future obligations of such JV Subsidiary Guarantor expressly subordinated in right of payment of such JV Subsidiary Guarantee; and
- be limited to the JV Entitlement Amount, and will rank at least *pari passu* with all other unsecured, unsubordinated Indebtedness of such JV Subsidiary Guarantor (subject to any priority rights of such unsubordinated Indebtedness pursuant to applicable law).

Security to be Granted . . . . .

The Company has agreed, for the benefit of the holders of the Notes, to pledge, or cause the initial Subsidiary Guarantor Pledgors to pledge, as the case may be, the Capital Stock of each initial Subsidiary Guarantor (collectively, the “Collateral”) in order to secure the obligations of the Company under the Notes and the Indenture and of such Subsidiary Guarantor Pledgor under its Subsidiary Guarantee.

The Collateral securing the Notes and the Subsidiary Guarantees may be released or reduced in the event of certain asset sales and certain other circumstances. In addition, the Collateral will be shared on a *pari passu* basis pursuant to the Intercreditor Agreement entered into by the holders of the Notes, the holders of the 2010 Notes, the holders of the 2012 Notes, the holders of the January 2013 Notes and the holders of other Permitted *Pari Passu* Secured Indebtedness (subject to conditions of completion and accession to the Intercreditor Agreement) on the date the Notes are issued. See “Description of the Notes — Security.”

Intercreditor Agreement . . . . .	The Company, the Subsidiary Guarantor Pledgors, the Collateral Agent, the trustee for the 2012 Notes and the trustee for the 2010 Notes have entered into an intercreditor agreement dated September 27, 2012, to which the trustee for the January 2013 Notes has acceded on January 22, 2013 and as amended or supplemented from time to time. The trustee for the Notes will accede to the Intercreditor Agreement, which provides that the security interests held in the Collateral will be shared on a <i>pari passu</i> basis among the holders of the 2010 Notes, the holders of the 2012 Notes, the holders of the January 2013 Notes, the holders of the Notes and the holders of other Permitted Pari Passu Secured Indebtedness.
Use of Proceeds . . . . .	<p>We intend to use the proceeds from this offering to refinance certain of our existing indebtedness, finance our existing and new property development projects (including land premium and construction costs), and for other general corporate purposes.</p> <p>We may adjust the foregoing plans in response to changing market conditions and, thus, reallocate the use of the proceeds. Pending application of the net proceeds of this offering, we intend to invest such net proceeds in Temporary Cash Investments as defined under “Description of the Notes.”</p>
Optional Redemption . . . . .	<p>At any time prior to maturity, the Company may at its option redeem the Notes, in whole but not in part, at a redemption price equal to 100% of the principal amount of the Notes plus the Applicable Premium (as defined under “Description of the Notes”) as of, and accrued and unpaid interest, if any, to (but not including) the redemption date.</p> <p>At any time and from time to time prior to maturity, the Company may redeem up to 35% of the aggregate principal amount of the Notes at a redemption price of 107.875% of the principal amount of the Notes, plus accrued and unpaid interest, if any, to (but not including) the redemption date, with the proceeds from sales of certain kinds of its capital stock, subject to certain conditions.</p>
Repurchase of Notes Upon a Change of Control Triggering Event . . . . .	Upon the occurrence of a Change of Control Triggering Event, the Company will make an offer to repurchase all outstanding Notes at a purchase price equal to 101% of their principal amount plus accrued and unpaid interest, if any, to (but not including) the repurchase date.

Redemption for Taxation Reason . . . . .	Subject to certain exceptions, the Company may redeem the Notes, as a whole but not in part, at a redemption price equal to 100% of the principal amount thereof, together with accrued and unpaid interest (including any Additional Amounts), if any, to the date fixed by the Company for redemption, if the Company or a Subsidiary Guarantor would become obligated to pay certain additional amounts as a result of certain changes in specified tax laws or certain other circumstances. See “Description of the Notes — Redemption for Taxation Reasons.”
Covenants . . . . .	<p>The Notes, the Indenture governing the Notes and the Subsidiary Guarantees will limit the Company’s ability and the ability of its Restricted Subsidiaries to, among other things:</p> <ul style="list-style-type: none"> <li>• incur or guarantee additional indebtedness and issue disqualified or preferred stock;</li> <li>• declare dividends on its capital stock or purchase or redeem capital stock;</li> <li>• make investments or other specified restricted payments;</li> <li>• issue or sell capital stock of Restricted Subsidiaries;</li> <li>• guarantee indebtedness of Restricted Subsidiaries;</li> <li>• sell assets;</li> <li>• create liens;</li> <li>• enter into sale and leaseback transactions;</li> <li>• enter into agreements that restrict the Restricted Subsidiaries’ ability to pay dividends, transfer assets or make intercompany loans;</li> <li>• enter into transactions with shareholders or affiliates; and</li> <li>• effect a consolidation or merger.</li> </ul> <p>These covenants are subject to a number of important qualifications and exceptions described in “Description of the Notes — Certain Covenants.”</p>
Transfer Restrictions . . . . .	The Notes will not be registered under the U.S. Securities Act or under any state securities laws of the United States and will be subject to customary restrictions on transfer and resale. See “Transfer Restrictions.”
Form, Denomination and Registration . . . . .	The Notes will be issued only in fully registered form, without coupons, in minimum denominations of CNY1,000,000 of principal amount and integral multiples of CNY100,000 in excess thereof and will be initially represented by one or more global notes registered in the name of a nominee of a sub-custodian nominated by the HKMA.

Clearance and Settlement . . . . .	Beneficial interests in the Notes will be shown on, and transfers thereof will be effected only through, book-entry records maintained by the Operator. For persons seeking to hold a beneficial interest in the Notes through Euroclear or Clearstream, such persons will hold their interests through an account opened and held by Euroclear or Clearstream with the Operator. For a description of certain factors relating to clearance and settlement, see “Description of the Notes — Book-Entry; Delivery and Form.”		
Delivery of the Notes . . . . .	The Company expects that the Notes will be ready for deliver on or about May 27, 2013 in book-entry form through the facilities of CMU. See “Plan of Distribution.”		
Trustee, Paying Agent, Note Registrar and CMU Lodging Agent . . . . .	Citicorp International Limited		
Collateral Agent . . . . .	Citicorp International Limited		
Listing . . . . .	Approval in-principle has been received for the listing and quotation of the Notes on the Official List of the SGX-ST. The Notes will be traded in a minimum board lot size of CNY200,000 with a minimum of six lots to be traded in a single transaction for so long as the Notes are listed on the SGX-ST and the rules of the SGX-ST so require.		
Governing Law . . . . .	The Notes and the Indenture will be governed by and will be construed in accordance with the laws of the State of New York. The relevant pledge documents will be governed under the laws of the jurisdiction in which the relevant Subsidiary Guarantor is incorporated.		
Risk Factors . . . . .	For a discussion of certain factors that should be considered in evaluating an investment in the Notes, see “Risk Factors.”		
Ratings . . . . .	The Notes have been rated B+ by Standard and Poor’s Rating Services and B2 by Moody’s Investors Service. We cannot assure investors that these ratings will not be adversely revised or withdrawn either before or after delivery of the Notes.		
Security Codes . . . . .	<u>Hong Kong ISIN</u>	<u>Common Code</u>	<u>CMU Instrument No.</u>
	HK0000150760	093560574	CILHFN13009

## SUMMARY CONSOLIDATED FINANCIAL AND OTHER DATA

The following table presents our summary financial and other data. The summary consolidated statement of comprehensive income data for 2010, 2011 and 2012 and the summary consolidated statement of financial position data as of December 31, 2010, 2011 and 2012 set forth below (except for EBITDA data) have been derived from our consolidated financial statements for such years and as of such dates, as audited by Deloitte Touche Tohmatsu (“Deloitte”), the independent certified public accountants, and included elsewhere in this offering memorandum. Our financial statements have been prepared and presented in accordance with HKFRS, which differ in certain respects from generally accepted accounting principles in other jurisdictions. Certain financial data as of and for the year ended December 31, 2011 set forth in the following table have been restated for comparison purposes as a result of our adoption of certain amendments to Hong Kong Accounting Standard 12 “Deferred Tax: Recovery of Underlying Assets” (“HKAS 12”) which became effective on January 1, 2012. Summary financial data as of and for the year ended December 31, 2010 set forth in the following table have not been restated and therefore, may not be comparable to those as of and for the years ended December 31, 2011 and 2012. See Note 2 to consolidated financial statements as of and for the year ended December 31, 2012 included elsewhere in this offering memorandum. The summary financial data below should be read in conjunction with the section entitled “Management’s Discussion and Analysis of Financial Condition and Results of Operations” and our consolidated financial statements and the notes to those statements included elsewhere in this offering memorandum.

### Summary Consolidated Statement of Comprehensive Income and Other Financial Data

	For the year ended December 31,			
	2010 (RMB)	2011 (RMB)	2012 (RMB)	2012 (US\$)
	(unaudited)			
	(in thousands)			
<b>Revenue</b> . . . . .	4,471,234	5,592,350	6,230,050	999,992
Cost of sales and services . . . . .	(2,546,440)	(3,200,650)	(3,709,778)	(595,460)
<b>Gross profit</b> . . . . .	1,924,794	2,391,700	2,520,272	404,532
Other income, gains and losses . . . . .	32,199	46,922	31,800	5,104
Change in fair value of investment properties . .	320,461	182,980	167,876	26,946
Recognition of change in fair value of completed properties for sale upon transfer to investment properties . . . . .	67,326	191,142	330,257	53,010
Selling and distribution expenses . . . . .	(131,278)	(262,433)	(314,100)	(50,417)
Administrative expenses . . . . .	(238,724)	(309,972)	(291,966)	(46,864)
Finance costs . . . . .	(180,131)	(108,471)	(57,698)	(9,261)
Impairment loss recognized in respect of goodwill . . . . .	(5,375)	(1,321)	–	–
Share of results of associates . . . . .	406	171	417	67
Gain on disposal of an associate . . . . .	–	3,533	–	–
Gain on disposal of a subsidiary . . . . .	–	17,589	–	–
<b>Profit before taxation</b> . . . . .	1,789,678	2,151,840	2,386,858	383,117
Income tax expense . . . . .	(828,708)	(1,038,344) <sup>(1)</sup>	(1,261,209)	(202,438)
<b>Profit for the year</b> . . . . .	960,970	1,113,496 <sup>(1)</sup>	1,125,649	180,679

	For the year ended December 31,			
	2010 (RMB)	2011 (RMB)	2012 (RMB)	2012 (US\$) (unaudited)
	(in thousands)			
<b>Other comprehensive income (expense)</b>				
Surplus on revaluation of properties . . . . .	–	11,795	45,708	7,337
Deferred taxation liability arising from revaluation of properties . . . . .	–	(4,851) <sup>(1)</sup>	(14,633)	(2,349)
Other comprehensive income for the year/period (net of income tax) . . . . .	–	6,944 <sup>(1)</sup>	31,075	4,988
<b>Total comprehensive income for the year . . . . .</b>	<u>960,970</u>	<u>1,120,440<sup>(1)</sup></u>	<u>1,156,724</u>	<u>185,667</u>
Profit for the year attributable to:				
Owners of the Company . . . . .	807,281	1,057,479 <sup>(1)</sup>	1,139,241	182,861
Non-controlling interests . . . . .	153,689	56,017	(13,592)	(2,182)
	<u>960,970</u>	<u>1,113,496<sup>(1)</sup></u>	<u>1,125,649</u>	<u>180,679</u>
Total comprehensive income attributable to:				
Owners of the Company . . . . .	807,281	1,064,423 <sup>(1)</sup>	1,163,210	186,708
Non-controlling interests . . . . .	153,689	56,017	(6,486)	(1,041)
	<u>960,970</u>	<u>1,120,440<sup>(1)</sup></u>	<u>1,156,724</u>	<u>185,667</u>
Earnings per share – Basic (RMB) . . . . .	0.17	0.21 <sup>(1)</sup>	0.22	0.04
<b>Other Financial Data</b>				
EBITDA <sup>(2)</sup> . . . . .	1,591,117	1,911,194	1,996,712	320,494
EBITDA margin <sup>(3)</sup> . . . . .	36%	34%	32%	32%

*Notes:*

(1) The Group has applied certain amendments to HKAS 12 that are mandatorily effective for the results for the year ended December 31, 2012. Under the amendments to HKAS 12, investment properties that are measured using the fair value model in accordance with Hong Kong Accounting Standard 40 “Investment Property” (“HKAS 40”) are presumed to be recovered through sale for the purposes of measuring deferred taxes, unless the presumption is rebutted in certain circumstances.

The Group measures its investment properties using the fair value model. As a result of the application of the amendments to HKAS 12, the directors reviewed the Group’s investment property portfolios and concluded that the Group’s investment properties are not held under a business model whose objective is to consume substantially all of the economic benefits embodied in the investment properties over time. Accordingly the presumption set out in the amendments to HKAS 12 is not rebutted.

As a result of the application of the amendments to HKAS 12, the Group recognized the deferred taxes on changes in fair value of the Group’s investment properties in PRC taking into account the land appreciation tax and enterprise income tax payable upon sales of those investment properties. Previously, the Group recognized deferred taxes on changes in fair value of investment properties on the basis that the entire carrying amounts of the properties were recovered through use.



The effect of the change in accounting policy described above on the results for the current and preceding year by line items presented in the consolidated statement of comprehensive income is as follows:

	For the year ended December 31,	
	2011	2012
	(RMB)	(RMB)
	(in thousands)	
Increase in income tax expense and decrease in profit for the year . . . . .	96,145	131,709
Increase in deferred tax charge recognised in other comprehensive income in relation to change in fair value of owner-occupied properties to investment properties . . . . .	1,902	3,205
	<u>98,047</u>	<u>134,914</u>
	For the year ended December 31,	
	2011	2012
	(RMB)	(RMB)
	(in thousands)	
<b>Impact on basic earnings per share</b>		
Basic earnings per share before adjustment . . . . .	0.23	0.24
Adjustments arising from change in accounting policy in relation to application of amendments to HKAS 12 in respect of deferred taxes on investment properties . . . . .	(0.02)	(0.02)
Reported basic earnings per share . . . . .	<u>0.21</u>	<u>0.22</u>

- (2) *EBITDA for any period consists of profit from operating activities before change in fair value of investment properties and impairment loss recognized in respect of goodwill plus depreciation and amortization expenses. EBITDA is not a standard measure under HKFRS. EBITDA is a widely used financial indicator of a company's ability to service and incur debt. EBITDA should not be considered in isolation or construed as an alternative to cash flows, net income or any other measure of financial performance or as an indicator of our operating performance, liquidity, profitability or cash flows generated by operating, investing or financing activities. EBITDA does not account for taxes, interest expense or other non-operating cash expenses. In evaluating EBITDA, we believe that investors should consider, among other things, the components of EBITDA such as sales and operating expenses and the amount by which EBITDA exceeds capital expenditures and other charges. We have included EBITDA because we believe it is a useful supplement to cash flow data as a measure of our performance and our ability to generate cash flow from operations to cover debt service and taxes. EBITDA presented herein may not be comparable to similarly titled measures presented by other companies. Investors should not compare our EBITDA to EBITDA presented by other companies because not all companies use the same definition. See the section entitled "Management's Discussion and Analysis of Financial Condition and Results of Operations — Non-GAAP Financial Measures" for a reconciliation of our profit for the year under HKFRS to our definition of EBITDA. Investors should also note that EBITDA as presented herein may be calculated differently from Consolidated EBITDA as defined and used in the Indenture governing the Notes. Interest expense excludes amounts capitalized. See the section entitled "Description of the Notes — Definitions" for a description of the manner in which Consolidated EBITDA is defined for purposes of the Indenture governing the Notes.*
- (3) *EBITDA margin is calculated by dividing EBITDA by revenue.*

## Summary Consolidated Statement of Financial Position

	As of December 31,			
	2010	2011	2012	2012
	(RMB)	(RMB)	(RMB)	(US\$)
	(unaudited)			
	(in thousands)			
<b>Non-current Assets</b>				
Property, plant and equipment . . . . .	374,434	529,215	585,687	94,009
Investment properties . . . . .	1,697,677	2,443,694	3,422,233	549,306
Interests in associates . . . . .	17,795	1,077	1,171	188
Interest in a jointly controlled entity . . . . .	–	–	19,720	3,165
Advance to an associate . . . . .	72,041	–	–	–
Goodwill . . . . .	–	–	16,488	2,647
Prepaid lease payments . . . . .	346,045	163,307	822,252	131,981
Premium on prepaid lease payments . . . . .	359,203	440,275	591,144	94,885
Prepayment . . . . .	43,370	11,890	–	–
Land development expenditure . . . . .	393,849	1,335,848	1,217,463	195,416
Deposits paid for acquisition of subsidiaries . . . . .	–	8,084	6,890	1,106
Deposits paid for acquisition of a property project . . . . .	37,000	104,900	126,004	20,225
Deposit paid for acquisition of land use rights . . . . .	–	–	158,123	25,380
Deferred tax assets . . . . .	157,504	220,826	329,372	52,868
	<u>3,498,918</u>	<u>5,259,116</u>	<u>7,296,547</u>	<u>1,171,176</u>
<b>Current Assets</b>				
Properties for sale . . . . .	7,644,582	10,222,320	11,372,628	1,825,433
Prepaid lease payments . . . . .	6,881	6,413	28,121	4,514
Premium on prepaid lease payments . . . . .	6,101	11,157	19,219	3,085
Deposits paid for acquisition of land use rights . . . . .	763,095	–	–	–
Trade and other receivables . . . . .	977,179	1,216,377	2,142,501	343,895
Amounts due from related parties . . . . .	7,500	3,262	–	–
Amounts due from customers for contract works . . . . .	15,939	16,359	52,482	8,424
Tax recoverable . . . . .	5,580	51,143	77,179	12,388
Financial assets at fair value through profit or loss . . . . .	–	–	42,200	6,774
Restricted bank deposits . . . . .	85,161	315,134	707,614	113,580
Bank balances and cash . . . . .	2,371,452	1,021,355	2,788,106	447,521
	<u>11,883,470</u>	<u>12,863,520</u>	<u>17,230,050</u>	<u>2,765,614</u>
<b>Current Liabilities</b>				
Trade and other payables . . . . .	1,686,718	2,268,829	2,603,457	417,884
Deposits received for sale of properties . . . . .	1,834,067	2,619,004	4,186,104	671,916
Amounts due to customers for contract works . . . . .	–	–	2,291	368
Amounts due to related parties . . . . .	100,549	2,547	1,573	252
Tax payable . . . . .	1,104,147	1,527,259	2,238,038	359,230
Borrowings – due within one year . . . . .	2,132,381	2,100,069	2,452,294	393,620
	<u>6,857,862</u>	<u>8,517,708</u>	<u>11,483,757</u>	<u>1,843,270</u>
<b>Net Current Assets</b> . . . . .	<u>5,025,608</u>	<u>4,345,812</u>	<u>5,746,293</u>	<u>922,344</u>
<b>Total Assets less Current Liabilities</b> . . . . .	<u>8,524,526</u>	<u>9,604,928</u>	<u>13,042,840</u>	<u>2,093,520</u>

	As of December 31,			
	2010 (RMB)	2011 (RMB)	2012 (RMB)	2012 (US\$)
	(unaudited)			
	(in thousands)			
<b>Non-Current Liabilities</b>				
Deferred tax liabilities . . . . .	128,121	429,372 <sup>(1)</sup>	692,558	111,163
Amount due to a related party . . . . .	–	–	–	–
Borrowings – due after one year . . . . .	2,642,605	2,640,933	3,100,113	497,602
Senior notes . . . . .	787,330	752,367	2,329,003	373,831
	<u>3,558,056</u>	<u>3,822,672<sup>(1)</sup></u>	<u>6,121,674</u>	<u>982,596</u>
	<u>4,966,470</u>	<u>5,782,256<sup>(1)</sup></u>	<u>6,921,166</u>	<u>1,110,924</u>
<b>Capital and Reserves</b>				
Share capital . . . . .	429,389	457,093	457,093	73,369
Reserves . . . . .	<u>4,072,745</u>	<u>5,144,506<sup>(1)</sup></u>	<u>6,144,037</u>	<u>986,186</u>
Equity attributable to owners of the Company . . . . .	4,502,134	5,601,599 <sup>(1)</sup>	6,601,130	1,059,555
Non-controlling interests . . . . .	464,336	180,657	320,036	51,369
	<u>4,966,470</u>	<u>5,782,256<sup>(1)</sup></u>	<u>6,921,166</u>	<u>1,110,924</u>

*Note:*

(1) The Group has applied certain amendments to HKAS 12 that are mandatorily effective for the results for the year ended December 31, 2012. Under the amendments to HKAS 12, investment properties that are measured using the fair value model in accordance with HKAS 40 are presumed to be recovered through sale for the purposes of measuring deferred taxes, unless the presumption is rebutted in certain circumstances.

The Group measures its investment properties using the fair value model. As a result of the application of the amendments to HKAS 12, the directors reviewed the Group's investment property portfolios and concluded that the Group's investment properties are not held under a business model whose objective is to consume substantially all of the economic benefits embodied in the investment properties over time. Accordingly the presumption set out in the amendments to HKAS 12 is not rebutted.

As a result of the application of the amendments to HKAS 12, the Group recognized the deferred taxes on changes in fair value of the Group's investment properties in PRC taking into account the land appreciation tax and enterprise income tax payable upon sales of those investment properties. Previously, the Group recognized deferred taxes on changes in fair value of investment properties on the basis that the entire carrying amounts of the properties were recovered through use.

The effect of the change in accounting policy described above on the financial positions of the Group as of December 31, 2011, is as follow:

	As of December 31, 2011	Adjustments	As of December 31, 2011
	(originally stated)		(restated)
	(RMB)	(RMB)	(RMB)
	(in thousands)		
Deferred tax liabilities and total effect of net assets . . . . .	<u>212,347</u>	<u>217,025</u>	<u>429,372</u>
Accumulated profits . . . . .	2,663,549	(166,628)	2,496,921
Special reserve . . . . .	(15,673)	(48,495)	(64,168)
Property revaluation reserve . . . . .	8,846	(1,902)	6,944
Total effect on equity . . . . .	<u>2,656,722</u>	<u>(217,025)</u>	<u>2,439,697</u>

The effect of the change in accounting policy described above on the financial positions of the Group as of January 1, 2011, is as follows:

	As of January 1, 2011		As of January 1, 2011
	(originally stated)	Adjustments	(restated)
	(RMB)	(RMB)	(RMB)
		(in thousands)	
Deferred tax liabilities and total effect on net assets . . . . .	128,121	118,978	247,099
Accumulated profits . . . . .	1,516,228	(70,483)	1,445,745
Non-controlling interests . . . . .	464,336	(48,495)	415,841
Total effect on equity. . . . .	1,980,564	(118,978)	1,861,586

## RISK FACTORS

*You should carefully consider the risks and uncertainties described below and other information contained in this offering memorandum before making an investment decision. The risks and uncertainties described below may not be the only ones that we face. Additional risks and uncertainties that we are not aware of or that we currently believe are immaterial may also adversely affect our business, financial condition or results of operations. If any of the possible events described below occur, our business, financial condition or results of operations could be materially and adversely affected. In such case, we may not be able to satisfy our obligations under the Notes, and you could lose all or part of your investment.*

### **Risks Relating to Our Business**

***We rely heavily on the strong performance of the property market in China, particularly in the Chengdu-Chongqing Economic Zone, the Pearl River Delta region, the Yangtze River Delta region and the Beijing-Tianjin metropolitan region***

Our growth in the past has benefited from the strong demand for properties in China, particularly in the Chengdu-Chongqing Economic Zone, the Pearl River Delta region, the Yangtze River Delta region and the Beijing-Tianjin metropolitan region, where a majority of our past and current property development projects are located. As we intend to continue to focus our efforts in these four regions, we will continue to depend in the near future on the continuous growth and performance of the property market in such regions. Market demand for residential and commercial properties and office spaces could be affected by various factors, including the general economic environment and any macro-economic control measures implemented by the PRC government, many of which are beyond our control. We cannot assure you that such demand will continue to grow or remain at previous levels in the future, especially in light of the current global financial and economic crisis. See “— We may be adversely affected by fluctuations in the global economy and financial markets.” Any adverse developments in the supply and demand of properties or in property prices in China, particularly in the Chengdu-Chongqing Economic Zone, the Pearl River Delta region, the Yangtze River Delta region and the Beijing-Tianjin metropolitan region, could have a material adverse effect on our business, financial condition and results of operations.

***Increasing competition in the PRC, particularly in the Chengdu-Chongqing and Pearl River Delta regions, may adversely affect our business and financial condition***

Sales in the Chengdu-Chongqing and Pearl River Delta regions accounted for a significant portion of our total contracted sales in 2011 and 2012. In recent years, an increasing number of property developers have begun property development in Chengdu-Chongqing and Pearl River Delta regions and elsewhere in the PRC. These include overseas property developers (including a number of leading Hong Kong property developers), and developers from other parts of the PRC, some of which may have better track records and greater financial and other resources than us. The intensity of the competition between property developers for land, financing, raw materials and skilled management and labor resources, in regions or cities where we operate, in particular, in the Chengdu-Chongqing and Pearl River Delta regions, may result in increased costs for the acquisition of land for development, an oversupply of properties in certain parts of the PRC, including the Chengdu-Chongqing and Pearl River Delta regions, a decrease in property prices and a slowdown in the rate at which new property developments will be approved and/or reviewed by the relevant government authorities, any of which may adversely affect our business and financial position. In addition, the property market in the Chengdu-Chongqing and Pearl River Delta regions and elsewhere in the PRC is rapidly changing. If we cannot respond to changes in market conditions more swiftly or more effectively than our competitors, our business, results of operations and financial condition could be adversely affected.

*We may not have adequate capital resources to fund our land acquisitions and property developments*

Property development is capital intensive. We principally fund our property developments from a combination of internal funds, borrowings from banks, proceeds from sales and pre-sales of our properties, capital contributions from shareholders and proceeds from issuance of equity and debt securities, such as our IPO in November 2009 and our offering of the 2010 Notes, the 2012 Notes and the January 2013 Notes. Our ability to secure sufficient financing for land acquisition and property development depends on a number of factors that are beyond our control, including market conditions in debt and equity capital markets, investors' perception of our securities, lenders' perception of our creditworthiness, the PRC economy and the PRC regulations that affect the availability and finance costs for real estate companies.

Various PRC regulations restrict our ability to raise capital through external financing and other methods, including without limitation, the following:

- we cannot pre-sell uncompleted units in a project prior to achieving certain development milestones;
- PRC banks are prohibited from extending loans to real estate companies for the purposes of funding the purchase of land use rights;
- we cannot borrow from a PRC bank for a particular project unless we fund at least 20% of the estimated total capital required for that project from our own capital;
- we cannot borrow from a PRC bank for a particular project unless we obtain the land use rights certificate, construction land planning permit, construction works planning permit and construction works commencement permit for that project;
- PRC banks are restricted from granting loans for the development of luxury residential properties;
- property developers are strictly prohibited from using the proceeds from a loan obtained from a local bank to fund property developments outside the region where that bank is located; and
- PRC banks are prohibited from accepting properties that have been vacant for more than three years as collateral for loans.

In addition, PBOC has adjusted the reserve requirement ratio for commercial banks six times in 2010, seven times in 2011 and twice in 2012. The reserve requirement ratio for commercial banks currently ranges from 10.5% to 20% with effect from May 18, 2012. Changes in the reserve requirement ratio affect the amount of funds that banks must hold in reserve against deposits made by their customers. Increase in such reserve requirement ratio will reduce the amount of commercial bank credit available to businesses in China, including us. In November 2009, the PRC government raised the minimum down payment for land premiums to 50% and in March 2010, the Ministry of Land and Resources stipulated that the minimum down payment of land premium of 50% should be paid within one month after the signing of a land grant contract and the rest of the land premium should be fully paid within one year after the signing of a land grant contract. Such change of policy may constrain our cash otherwise available for additional land acquisition and construction.

The PRC government may introduce other measures that limit our access to additional capital. For example, in November 2007, China Banking Regulatory Commission (the "CBRC") provided policy guidelines to the PRC banks and Chinese subsidiaries of foreign banks that loans outstanding as of December 31, 2007 should not exceed the level of outstanding loans as of October 31, 2007. This lending freeze may limit our ability to access additional loans or to rollover existing loans as they mature, and may also prevent or delay potential customers' ability to secure mortgage loans to purchase residential properties. In addition, on July 10, 2007, the General Department of the State Administration of Foreign Exchange (the "SAFE") issued the Circular on Distribution of List of the First Group of Foreign-Invested

Real Estate Projects Filed with the Ministry of Commerce (關於下發第一批通過商務部備案的外商投資房地產項目名單的通知) which restricts a foreign-invested property developer's ability to raise capital through foreign debt, if such developer is established after June 1, 2007 or increases its registered capital after June 1, 2007. Under this circular, our ability to utilize the proceeds of this offering to provide funding to our PRC operations is further limited. See "Regulation — I. Legal Supervision Relating to the Property Sector in the PRC — F. Property Credit" to this offering memorandum for further details.

We cannot assure you that we will be able to renew our current credit facilities or obtain sufficient funding to finance intended purchases of land use rights, develop future projects or meet other capital needs as and when required at a commercially reasonable cost or at all. Failure to obtain adequate funding at a commercially reasonable cost may limit our ability to commence new projects or to continue the development of existing projects. Such failure may also increase our finance costs.

***We may be adversely affected by fluctuations in the global economy and financial markets***

The global economic slowdown and turmoil in the global financial markets that started in the second half of 2008 have had a negative impact on the world economy, which in turn has affected the PRC real estate industry and many other industries. Since then PRC and many other foreign economies have shown signs of recovery. In 2010, a financial crisis emerged in Europe, triggered by high budget deficits and rising direct and contingent sovereign debt in Greece, Ireland, Italy, Portugal and Spain, which created concerns about the ability of these European nations to continue to service their sovereign debt obligations. On August 6, 2011, Standard and Poor's Ratings Services ("S&P") downgraded the rating for long-term United States debt to "AA+" from "AAA" for the first time in 70 years. The downgrade of United States debt by S&P, coupled with the economic turmoil in Europe and other parts of the world could lead to another global economic downturn and financial market crisis.

The outlook for the world economy and financial markets remains uncertain. In Europe, several countries are facing difficulties in refinancing sovereign debt. In the United States, the unemployment rate remains high, and recovery in the housing market remains subdued. In Asia and other emerging markets, some countries are expecting increasing inflationary pressure as a consequence of liberal monetary policy or excessive foreign fund inflow, or both. In the Middle East, political unrest in various countries has resulted in economic instability and uncertainty. China's economic growth may slow down due to weakened exports.

These and other issues resulting from the global economic slowdown and financial market turmoil have adversely affected, and may continue adversely affecting, homeowners and potential property purchasers, which may lead to a decline in the general demand for our products and erosion of their sale prices. In addition, any further tightening of liquidity in the global financial markets may negatively affect our liquidity. Therefore, if the global economic slowdown and turmoil in the financial markets crisis continue, our business, financial condition and results of operations may be adversely affected.

***Our business may be adversely affected by changes in interest rates***

We rely on borrowings to finance a substantial part of our project developments. Currently, our borrowings primarily consist of loans from commercial banks in China. Many of our customers also need to finance their purchase of our properties through mortgage loans. Interest rates in the PRC have decreased several times recently. The PBOC has adjusted the benchmark one-year lending rate numerous times in the past in response to the changing PRC and global financial and economic conditions. We cannot assure you that the PBOC will decrease the benchmark one-year lending rate or that the interest rates at which financing will be available to us or our customers will decrease in the future. In addition, we cannot predict if and when interest rate in the PRC may increase. Any increase in the interest rates will increase our finance costs and also increase the costs of our customers to purchase our properties with mortgages and therefore adversely affect our business, financial conditions and results of operation. See "— The terms on which mortgages are available, if at all, may affect our sales."

***We may not always be able to obtain land sites that are suitable for property development within our budget***

We derive a significant portion of our revenue from sales of properties that we have developed. This revenue stream depends on the completion of, and our ability to sell, our properties. To maintain or grow our business in the future we will need to replenish our land reserves with suitable development sites. Our ability to identify and acquire suitable land sites is subject to a number of factors, some of which are beyond our control. Our business, financial condition and results of operations may be materially and adversely affected if we are unable to obtain land sites for development at prices that allow us to achieve reasonable returns upon the sale of developed properties to our customers.

The PRC government controls all new land supply in the PRC and regulates land sales in the secondary market. As a result, the policies of the PRC government towards land supply may adversely affect our ability to acquire land use rights for sites we seek to develop and could increase the costs of any acquisition. The PRC central and local governments may regulate the means by which property developers, including us, obtain land sites for property developments. In recent years, the PRC government has promulgated policies that restrict banks from granting loans to finance the construction of luxury residential properties and limit or prohibit the supply of land available for projects such as villa-style developments, low density housing developments and golf courses. Although we will continue to seek suitable development opportunities, the current or future regulatory climate may restrict our ability to engage in such developments in the future. See also “— Risks Relating to Our Industry — PRC government policies, regulations and measures intended to curtail the overheating of the property market may adversely affect our business.”

***We have entered into several preliminary framework agreements for potential new property development projects which are subject to significant risks and uncertainties***

Subsequent to December 31, 2012, we have entered into certain framework agreements and formal agreements in relation to acquisition of parcels of land with a total site area of approximately 257,399 square meters and an aggregate planned GFA of approximately 851,484 square meters with third parties or with local governments in which the projects are located. There are significant risks with respect to these potential new projects as further agreements are required to be entered into in order for us to obtain the respective land use rights for the land parcels specified in the preliminary framework agreements. In addition, in order to obtain the land use rights for some of these potential new projects, we will be required to go through public tender, auction or listing-for-sale processes in accordance with the relevant PRC regulations. We may not be able to successfully obtain the land use rights for the lands specified in the preliminary framework agreements through such processes or obtain the land use rights that can be used for the same purpose as those indicated in the preliminary framework agreements. If we fail to obtain the land use rights certificates for these parcels of land or other parcels of land in which we may acquire an interest in the future, we will not be able to develop and sell properties on such land. We may not be able to acquire replacement parcels of land on terms acceptable to us, or at all, which could have a material adverse effect on our future prospects, business, financial condition and results of operations.

Further, we may not be able to enter into future agreements to obtain the land parcels due to reasons that are beyond our control. Changes in the PRC regulatory environment or policies or changes in the general economic environment or property market in China may result in the other parties' unwillingness or inability to implement the transactions contemplated under the preliminary framework agreements, or result in changes to the general understanding of the preliminary framework agreements that may be adverse to us, including changes in the price of the land use rights to the specified land parcels. The preliminary framework agreements may not be considered as enforceable by the relevant PRC courts for the purpose of entering into future agreements to obtain the relevant land parcels. If we cannot obtain the relevant land parcels contemplated under the preliminary framework agreements in accordance with the understanding of the preliminary framework agreements or at all, our business and future prospects could be materially and adversely affected.



***We face uncertainties when obtaining land sites through the acquisition of project companies***

We have in the past, from time to time, obtained land sites for our projects through acquisition of project companies that held the land use rights, in addition to increasing our land bank through public tender, auction and listing-for-sale. We may continue to obtain land sites through such acquisitions in the future. We cannot assure you that we have discovered, or will be able to discover, all existing or potential liabilities of the target project companies. In addition, the government may change the permitted use of the land sites to which such project companies own the land use rights after our acquisitions, rendering the land sites unsuitable for our property development purposes. If any of the undiscovered existing or potential liabilities of the acquired project companies are found to be material, or if we are unable to develop properties on the land sites to which the acquired project companies have the land use rights, our business, financial conditions and results of operations may be materially and adversely affected. In addition, we may acquire such project companies for an amount that is less than their fair market value, resulting in gains recognized on our consolidated statements of comprehensive income. However, such gains do not give rise to any change to our cash position and therefore we may experience constraints on our liquidity even though our profitability increased.

***Our results of operations may be materially and adversely affected if we fail to obtain, or there are material delays in obtaining, requisite governmental approvals for our property developments***

The property industry in the PRC is heavily regulated by the PRC government. Property developers in China must comply with various requirements mandated by national and local laws and regulations, including the policies and procedures established by local authorities designed for the implementation of such laws and regulations. In order to develop and complete a property development, at various stages of the property development, a property developer must obtain various permits, licenses, certificates and other approvals from the relevant administrative authorities including a land use rights certificate, a construction land planning permit, a construction works planning permit, a construction works commencement permit and a pre-sale permit or confirmation of completion and acceptance. Each approval may depend on the satisfaction of certain conditions. See “Regulation — I. Legal Supervision Relating to the Property Sector in the PRC — D. Development of a Property Project.” We cannot assure you that we will not encounter material delays or other impediments in fulfilling the conditions precedent to the approvals, or that we will be able to adapt to new laws, regulations or policies that may come into effect from time to time with respect to the property industry in general or the particular processes with respect to regulatory approvals. There may also be delays on the part of the relevant regulatory bodies in reviewing our applications and granting approvals. If we fail to obtain, or encounter material delays in obtaining, the requisite governmental approvals, the completion of our developments and sale of our properties could be substantially disrupted or delayed and any such disruption or delay would materially and adversely affect our business, results of operations and financial condition. Furthermore, the relevant regulatory bodies may not approve the development plans for our projects and we may need to amend such development plans to obtain the necessary permits. Amendment to our development plans may have a material and adverse effect on our business and results of operations.

***We face intense competition with respect to our property development, property operation services, property agency services and hotel services businesses***

The property industry in the PRC is highly competitive and we face competition as to our property development business from major domestic developers and, to a lesser extent, foreign developers primarily from other countries or regions in Asia, including several leading developers from Hong Kong. Competition among property developers may increase the costs for land acquisitions and raw materials and administrative costs for hiring or retaining qualified personnel, result in shortages of skilled contractors and oversupply of properties, decrease property prices in certain parts of the PRC, and slowdown the rate at which new property developments will be approved and/or reviewed by the relevant government authorities, any of which may adversely affect our business and financial condition. In addition, the PRC government’s recent measures designed to reduce land supply further increased competition for land among property developers. Certain of our competitors are well capitalized and have greater financial, marketing and other resources than we have. Some also have larger land banks, greater economies of scale, better brand recognition, longer track record and more established relationships with contractors, suppliers and customers in certain markets. Such property developers may be able to respond

to changes in market conditions more promptly and effectively than we can, or may be more competitive in acquiring land through auction or other processes. If we are unable to maintain a competitive position with respect to the acquisition of land, adapt to changing market conditions or otherwise compete successfully with our competitors, our prospects, business, financial condition and results of operations may be materially and adversely affected.

In addition, we face intense competition as to our property operation services business and hotel services business at the national, regional and local levels. Competition in such businesses is based on quality of services, brand name recognition, geographic coverage, commission rates and range of services. Unlike property development business, such businesses have a low entry barrier and do not require significant capital commitments. This low entry barrier allows new competitors to enter into the market with relative ease. New and existing competitors may offer competitive rates, greater convenience or superior services, which could attract our customers away from us. Competition among companies providing such services may cause a decrease in commission rates and higher costs to attract or retain talented employees. Furthermore, our relative competitive position varies significantly by service type and geographic area. Certain of our competitors may be smaller than us but may be more established and have greater market presence and brand name recognition on a local or regional basis, while certain competitors are large national and international firms that may have more financial or other resources than us. If we fail to compete effectively, our property operation services business and hotel services business may suffer and our results of operations may be materially and adversely affected.

***The terms on which mortgages are available, if at all, may affect our sales***

Most of our purchasers rely on mortgages to fund their purchases. An increase in interest rates may significantly increase the cost of mortgage financing, thus reducing the attractiveness of mortgages as a source of financing for property purchases and adversely affecting the affordability of residential properties. In addition, the PRC government and commercial banks may also increase down payment requirements, impose other conditions or otherwise change the regulatory framework in a manner that would make mortgage financing unattractive or unavailable to potential property purchasers.

The CBRC issued a regulation on September 2, 2004 to limit mortgage loans on properties to no more than 80% of the sale price of the underlying properties. On March 17, 2005, the PBOC set forth the minimum interest rate for property mortgage loans to 0.9 times the corresponding benchmark lending rates, resulting in an increase in the minimum interest rate for mortgages. In May 2006, the PRC government increased the minimum amount of down payment to 30% of the purchase price for properties with a GFA of more than 90 square meters. In September 2007, the minimum down payment for any purchase of second or subsequent residential property was increased to 40% of the purchase price if the purchaser had obtained a bank loan to finance the purchase of his or her first property. Moreover, the interest rate for bank loans for such purchases shall not be less than 110% of the PBOC benchmark lending rate of the same term and category. For further purchases of properties, there would be upward adjustments on the minimum down payment and interest rate for any bank loan. In addition, mortgagee banks may not lend to any individual borrower if the monthly repayment of the anticipated mortgage loan would exceed 50% of the individual borrower's monthly income or if the total debt service of the individual borrower would exceed 55% of such individual's monthly income. In December 2007, the PBOC and CBRC issued another notice to clarify that, in determining the applicability of the relevant restrictions, the number of mortgage loans deemed to have been borrowed by a borrower shall include mortgage loans borrowed by any member of his or her family. In October 2008, in response to the global financial and economic crisis, the PBOC decreased the minimum amount of down payment for residential property purchases to 20% and reduced the minimum interest rate for mortgage loans for such purchases to 70% of the benchmark lending rate. However, despite such decrease in lending requirements, certain PRC banks have implemented their own internal restrictive conditions which limited the number of borrowers that can take advantage of the reduced requirements as announced by the PBOC. On April 17, 2010, the State Council issued a notice to raise the minimum down payment for second home purchases to 50% and set a minimum 30% down payment on first homes with a GFA of more than 90 square meters. Further, pursuant to such notice, the interest rate for mortgage loans of second homes cannot be lower than 110% of the PBOC benchmark lending rate. On September 29, 2010, the PBOC and the CBRC issued a notice to prohibit (i) commercial banks from providing housing mortgages to any members of a family unit purchasing their third or subsequent residential house or non-local residents who fail to provide one

year or longer worth of local tax payment certificates or social insurance payment certificates; and (ii) commercial banks from granting or extending loans to property developers that violate laws and regulations. See “Regulation – I. Legal Supervision Relating to the Property Sector in the PRC – E. Transfer and Sale of Property – (iii) Mortgages of Property” and “Regulation – I. Legal Supervision Relating to the Property Sector in the PRC – F. Property Credit.” In the event that mortgage loans for property purchases becomes more difficult to obtain or that the costs of such financing increases, many of our prospective customers who rely on such financing may not be able to purchase our properties, which in turn will materially and adversely affect our business, financial condition and results of operations.

In line with industry practice, we provide guarantees to banks for mortgage loans they offer to purchasers of our properties. If there are changes in laws, regulations, policies and practices that would prohibit property developers from providing guarantees to banks in respect of mortgages offered to property purchasers and these banks would not accept any alternative guarantees by other third parties, or if no third party is available in the market to provide such guarantees, it may become more difficult for property purchasers to obtain mortgages from banks during pre-sales. Such difficulties in financing could result in a substantially lower rate of pre-sales of our properties, which could adversely affect our business, financial condition and results of operations. We are not aware of any impending changes in laws, regulations, policies or practices which will prohibit such practice in the PRC. However, we cannot assure you that such changes in laws, regulations, policies or practices will not occur in the future.

***Changes in laws and regulations in relation to the pre-sale of properties may adversely affect our business, financial condition and results of operations***

Proceeds from the pre-sales of our properties are an important source of funds for the respective property developments and have an impact on our cash flow and liquidity position. On August 5, 2005, the PBOC proposed in a report entitled “2004 Real Estate Financing Report (2004中國房地產金融報告)” that the practice of pre-selling uncompleted properties be discontinued, on the grounds that such practice creates significant market risks and generates transactional irregularities. While such proposal has not been adopted by any PRC government authorities and has no mandatory effect, we cannot assure you that the PRC government will not ban or impose material limitations on presales of uncompleted properties in the future. Future implementation of any restrictions on our ability to pre-sell our properties, including any requirements to increase the amount of up-front expenditure we must incur prior to obtaining the pre-sale permit, would extend the time required for recovery of our capital outlay and would force us to seek alternative means to finance the various stages of our property development. This, in turn, could have a material and adverse effect on our business, financial condition and results of operations.

***We are exposed to pre-sale related contractual and legal risks***

We make certain undertakings in our pre-sale contracts. Our pre-sale contracts and the PRC laws and regulations provide for remedies for breach of these undertakings. For example, if we pre-sell units in a property development and we fail to complete that development, we will be liable to the purchasers for their losses. If we fail to complete a pre-sold property on time, we may be liable to the relevant purchasers for such late delivery under the relevant pre-sale contracts or pursuant to relevant PRC laws and regulations. If our delay extends beyond a specified period, the purchasers may terminate their pre-sale contracts and claim for damages. A purchaser may also claim damages against us if the GFA of the relevant unit, as set out in the individual property ownership certificate, deviates by more than 3% from the GFA of that unit set out in his or her contract. We cannot assure you that we will not experience delays in the completion and delivery of our properties, nor that the GFA for a delivered unit will not deviate more than 3% from the GFA set out in the relevant pre-sale contract.

***We cannot assure you that services performed by independent contractors will always meet our quality standards and timing requirement or will be available within our budget***

We engage independent contractors to provide various services, including but not limited to construction, piling and foundation, engineering, interior decoration, mechanical and electrical installation and utilities installation. We generally select independent contractors through an open tender process. We cannot assure you that we will be able to obtain services from independent contractors within our budget or at all, or the services rendered by any of these independent contractors or subcontractors will always be satisfactory or meet our quality and safety standards and our timing requirement. If the performance of any independent contractor is not satisfactory or is delayed, we may need to replace such contractor or take other actions to remedy the situation, which could adversely affect the cost and construction progress of our projects. Moreover, the completion of our property developments may be delayed, and we may incur additional costs due to a contractor's financial or other difficulties. Any of these factors could have a material adverse effect on our business, financial condition and results of operations.

***If we are not properly insulated from the rising cost of labor, construction materials or building equipment, our results of operations may be adversely affected***

As the result of economic growth and the boom in the property industry in the PRC, wages for construction workers and the prices of construction materials and building equipment have experienced substantial increases in recent years. In addition, the PRC Labor Contract Law (中華人民共和國勞動合同法) that came into effect on January 1, 2008 enhanced the protection for employees and increased employers' liability which may further increase our labor costs. Under the terms of most of our construction contracts, the construction contractors are responsible for the wages of construction workers and procuring construction materials for our property development and bear the risk of fluctuations in wages and construction material prices during the term of the relevant contract. However, we are exposed to the price volatility of labor and construction materials to the extent that we periodically enter into new or renew existing construction contracts at different terms during the life of a project, which may span over several years, or if we choose to hire the construction workers directly or purchase the construction materials directly from suppliers. We are also exposed to the price volatility of building equipment used in properties developed by us because we usually procure such equipment ourselves. Furthermore, we typically pre-sell our properties prior to their completion and we will be unable to pass the increased costs on to purchasers of our properties if the construction costs increase subsequent to the time of such pre-sale. If we are unable to pass on any increase in the cost of labor, construction materials and building equipment to either our construction contractors or to the purchasers of our properties, our results of operations may be adversely affected.

***We may be subject to legal and business risks if we fail to obtain, renew or keep necessary qualification certificates for our property development, property operation services, hotel services, property investment and property agency services businesses***

Property developers in the PRC must obtain a qualification certificate in order to engage in property development businesses in the PRC. Property developers in the PRC must also produce a valid qualification certificate when they apply for a pre-sale permit. According to the Provisions on Administration of Qualifications of Property Developers (房地產開發企業資質管理規定), newly established property developers must first apply for a provisional qualification certificate, which is valid for one year and can be renewed for a maximum of two additional years. A property developer is required to obtain a formal qualification certificate before its provisional qualification certificate expires. All formal qualification certificates are subject to verification on an annual basis. If the newly established property developer fails to commence a property development project within the one-year period when the provisional qualification certificate is in effect, it will not be allowed to extend its provisional qualification certificate. It is mandatory under government regulations that developers fulfill all statutory requirements before obtaining or renewing their qualification certificates. See "Regulation — I. Legal Supervision Relating to the Property Sector in the PRC — C. Qualifications of a Property Development Enterprise."

As of December 31, 2012, we had 32 project companies that were, or expected to be, engaged in the property development business, of which 19 had obtained formal qualification certificates, and 13 had obtained provisional qualification certificates. If any of our project companies that are, or expect to be, engaged in property development business is unable to meet the relevant requirements and therefore unable to obtain or renew its provisional qualification certificate, obtain its formal qualification certificate when its provisional qualification certificate expires, or pass the annual verification of its formal qualification certificate, such project company will be given a deadline within which it has to meet these requirements and it will also be subject to a penalty of between RMB50,000 and RMB100,000. Failure to meet the requirements within the deadline could result in the revocation of the qualification certificate and the business license of the relevant project company. We cannot assure you that we will be able to pass the annual verification of the qualification certificates of each of our project companies or that we will be able to renew our provisional qualification certificates or obtain formal qualification certificates in a timely manner, or at all, as and when the provisional qualification certificates expire.

Our PRC subsidiaries engaged in the property operation services (including property management services, building equipment installation, maintenance and repair services and information network services), hotel services and property investment businesses are required to obtain relevant qualification certificates from competent PRC government agencies for the provision of their services and some such qualification certificates are subject to annual verifications. As of December 31, 2012, except for Tianjin Xintang Property Management Company Limited (“Tianjin Xintang”) and Shenyang Auspicious Baxter Property Services Company Limited (“Shenyang Auspicious Baxter”), all of our PRC subsidiaries engaged in the property operation services, hotel services and property investment businesses had obtained or were in the process of obtaining the required qualification certificates. The qualification certificates for property management services held by Tianjin Xintang and Shenyang Auspicious Baxter have expired and have not been renewed. The services that Tianjin Xintang and Shenyang Auspicious Baxter used to provide are now provided by the Tianjin branch and the Shenyang branch of Shenzhen Colour Life Services Group Limited, respectively. We cannot assure you that our PRC subsidiaries engaged in the property operation services, hotel services and property investment businesses will be able to pass the annual verification of their qualification certificates or that we will be able to obtain new qualification certificates for our subsidiaries that may engage in the property operation services, hotel services and property investment businesses in the future.

We are also subject to numerous national, regional and local laws and regulations specific to the property agency services. If we fail to properly file records or to obtain or maintain the licenses and permits for conducting property agency services, we may be ordered to cease conducting the relevant real estate services and be subject to warning, fines and revocation of its licenses. As the size and scope of real estate transactions have increased significantly during the past several years, both the difficulty of ensuring compliance with the multiple levels of licensing regimes and the possible loss resulting from non-compliance have increased. In addition, the PRC government amended the Foreign Investment Industrial Guidance Catalogue (外商投資產業指導目錄) in December 2007 and 2011 and included property agency services into the category of businesses that are restricted for foreign investments. Although the current scope of our business operations is in full compliance with such catalogue, this revision would subject us to approvals of higher-level governmental authorities and heightened scrutiny if we want to expand our property agency business by acquiring other property agency companies, establishing new subsidiaries to provide property agency services. We cannot assure you that we will be able to obtain such approvals when we want to expand our property agency business. See the section entitled “Regulation.”

If our PRC subsidiaries engaged in the property operation services, hotel services and property investment and property agency services businesses are unable to obtain, renew or keep their qualification certificates, they may not be permitted to continue their business, which could materially and adversely affect our business, financial condition, results of operations and reputation.

***We may not be able to complete our property development projects on time or within our budget or at all***

Property development projects require substantial capital expenditures prior to and during the construction period and the construction of a property project may take longer than a year before it generates positive cash flows through pre-sales, sales or leases. The progress and costs for a property development project can be adversely affected by many factors, including, without limitation:

- delays in obtaining necessary licenses, permits or approvals from government agencies or authorities;
- relocation of existing residents and/or demolition of existing structures;
- unforeseen engineering, design, environmental or geographic problems;
- shortages of materials, equipment, contractors and skilled labor;
- labor disputes;
- construction accidents;
- natural catastrophes;
- adverse weather conditions;
- discovery of artifacts in the construction site; and
- changes in government policies.

Construction delays or failure to complete the construction of a project according to its planned specifications, schedule or budget as a result of the above factors may affect our financial condition and results of operations and may also cause damage to our reputation. In addition, if a pre-sold property development is not completed on time, the purchaser may be entitled to damages for late delivery. We cannot assure you that we will not experience any significant delays in completion or delivery or that we will not be subject to any liabilities for any such delays. If the delay extends beyond the contractually specified period, the purchaser would be entitled to terminate the purchase contract and claim damages. Therefore, any delay in completion of our property developments could have a material adverse impact on our business, financial condition and results of operations.

***We may not be successful in expanding our business into new geographical regions or cities***

Our revenues are primarily derived from our operations in the Chengdu-Chongqing Economic Zone, the Pearl River Delta region, the Yangtze River Delta region and the Beijing-Tianjin metropolitan region. We may expand into additional cities in these regions or expand into new regions in the future. Such new regions or cities may differ from our existing markets in terms of the level of economic development, demography, topography, property trends and regulatory practices. Therefore, we may not be able to replicate our successful business model in our existing markets to these other regions or cities. In addition, as we enter into new markets, we may not have the same level of familiarity with contractors, business practices and customs and customer tastes, behavior and preferences. Therefore, we may not be able to successfully leverage our existing experience to expand our property development, property operation services business, property agency services business and hotel services business into these other markets. We may also face intense competition from other developers, other companies that provide property operation services and other property agency companies with more established experience or presence in those markets.

***We may expand our business into new segments of the property industry which may not be successful***

We may expand our business into new segments of the property industry in the PRC as well as continue to expand the property services businesses that we currently operate. While we have accumulated experience in property development and in providing property operation services and property agency services, we cannot assure you that we will be able to leverage such experience and replicate our historical success when entering into new businesses. The expansion of our existing property services businesses and the expansion into new businesses may require a significant amount of capital investment and involve various risks and uncertainties, including the risk of operating in a new environment, the difficulties of integrating new businesses into our existing businesses and the diversion of resources and attention of our management. Any failure to address these risks and uncertainties may adversely affect our business, financial condition and results of operations.

***We may not be able to successfully manage our growth***

We have been rapidly expanding our operations in recent years. As we continue to grow, we must continue to improve our managerial, technical and operational knowledge and allocation of resources, and to implement an effective management information system. To effectively manage our expanded operations, we need to continue to recruit and train managerial, accounting, internal audit, engineering, technical, sales and other staff to satisfy our development requirements. In order to fund our ongoing operations and our future growth, we need to have sufficient internal sources of liquidity or access to additional financing from external sources. Further, we will be required to manage relationships with a greater number of customers, suppliers, contractors, service providers, lenders and other third parties. We will need to further strengthen our internal control and compliance functions to ensure that we are able to comply with our legal and contractual obligations and reduce our operational and compliance risks. We cannot assure you that we will not experience issues such as capital constraints, construction delays, operational difficulties at new operational locations or difficulties in expanding our existing business and operations and training an increasing number of personnel to manage and operate the expanded business. Neither can we assure you that our expansion plans will not adversely affect our existing operations and thereby have a material adverse effect on our business, financial condition, results of operations and future prospects.

***The illiquid nature and the lack of alternative uses of investment properties could limit our ability to respond to adverse changes in the performance of our properties***

Investment properties are relatively illiquid compared to other types of investments such as publicly traded equity securities. As a result, our ability to promptly sell one or more of our investment properties in response to changing economic, financial and investment conditions is limited. The property market is affected by many factors that are beyond our control, including general economic conditions, the availability of mortgage financing and interest rates, and we cannot accurately determine the market price of our investment properties nor are we able to predict whether we will be able to sell any of our investment properties at the price or on the terms set by us, or whether any price or other terms offered by a prospective purchaser would be acceptable to us. In addition, investment properties may not be readily convertible for alternative uses without substantial capital expenditure if the original function of such investment property became unprofitable due to competition, age, decreased demand or other factors. Similarly, for certain investment properties to be sold, substantial capital expenditure may be required to correct defects or make improvements to the property due to factors such as change in building regulations or as a result of age, compounding the effort and time required. These factors and any others that would impede our ability to respond to adverse changes in the performance of our investment properties could materially and adversely affect our business, financial condition and results of operations.

***Property owners may terminate our engagement as the provider of property management services***

We provide property management services through Colour Life Services Group Co., Ltd. (“Colour Life”) and its subsidiaries (together with Colour Life, the “Colour Life Group”) and Fantasia Property Management (International) Company Limited to our own developed projects and the projects of other developers. We believe that property management is an integral part of our business and critical to the successful marketing and promotion of our property developments as well as an important source of revenue. Under the PRC laws and regulations, owners of the same residential community of certain scale have the right to change the property management service provider upon the consent from a certain percentage of the owners of such community. If owners of the properties that we manage choose to terminate our property management services, or property buyers dislike our property management services, our reputation and results of operations could be materially and adversely affected.

***Any failure to protect our brand and trademarks could have a negative impact on our business***

We believe our brands and trademarks are critical to our success. Any unauthorized use of our brands, trademarks and other intellectual property rights could harm our competitive advantages and business. Historically, China has not protected intellectual property rights to the same extent as certain other countries, and infringement of intellectual property rights continues to pose a serious risk of doing business in China. Monitoring and preventing unauthorized use is difficult. The measures we take to protect our intellectual property rights may not be adequate. Furthermore, the application of laws governing intellectual property rights in China and abroad is uncertain and evolving. If we are unable to adequately protect our brand, trademarks and other intellectual property rights, we may lose these rights and our business may suffer materially.

***If the value of our brand or image diminishes, our business and results of operations may be materially and adversely affected***

Our brands and images play an integral role in all of our business operations. Our continued success in maintaining and enhancing our brands and images depends to a large extent on our ability to satisfy customer needs by further maintaining and improving our product quality or quality of services across our operations, as well as our ability to respond to competitive pressures. If we are unable to satisfy customer needs or if our public image or reputation were otherwise diminished, our business transactions with our customers may decline which could in turn adversely affect our results of operations.

In addition, as we provide property operation services and property agency services to third party developers, our brand and images may be adversely affected as a result of significant quality defects in the properties developed by third party developers or negative publicity or other problems related to third party developers. The ability of our subsidiary to successfully sell or manage the properties of such third party developers may be materially and adversely affected, which may in turn adversely affect our long-term ability to attract purchasers for the properties we are contracted to sell, including those properties developed by us, or to attract management opportunities in respect of the properties developed by third party developers.

***Our indebtedness could have an adverse effect on our financial condition, diminish our ability to raise additional capital to fund our operations and limit our ability to explore business opportunities***

We maintain a certain level of indebtedness to finance our operations. As of December 31, 2012, the outstanding balance of our total debt (including aggregate outstanding borrowings and amounts due to related parties) amounted to RMB7,881.4 million (US\$1,265.1 million). Our indebtedness described above could have an adverse effect on us, such as:

- requiring us to dedicate a large portion of our cash flow from operations to fund repayments on our debt, thereby reducing the availability of our cash flow to expand our business;
- increasing our vulnerability to adverse general economic or industry conditions;
- limiting our flexibility in planning for, or reacting to, changes in our business or the industry in which we operate;



- limiting our ability to raise additional debt or equity capital in the future or increasing the cost of such funding;
- restricting us from making strategic acquisitions or exploring potential business opportunities; and
- making it more difficult for us to satisfy our obligations with respect to our debt.

We have incurred and will continue to incur a significant amount of finance costs in relation to our indebtedness. A significant portion of our finance costs are capitalized rather than being expensed at the time it is incurred to the extent such costs are directly attributable to the acquisition and construction of a project or a projected phase. See “Management’s Discussion and Analysis of Financial Condition and Results of Operations — Key Factors Affecting Our Results of Operations — Access to and Cost of Financing.”

In addition, as our indebtedness will require us to maintain an adequate level of cash flow from operations to satisfy our debt obligations as they become due, any decrease in our cash flow from operations in the future may have a material and adverse effect on our financial condition.

***We guarantee mortgage loans provided to our purchasers and may be liable to the mortgagee banks if our purchasers default on their mortgage loans***

We arrange for various domestic banks to provide mortgage loans to the purchasers of our properties. According to market practice, domestic banks require us to guarantee these mortgage loans until the relevant property ownership certificates are issued, which generally takes place within one to two years after we deliver possession of the relevant property to the purchasers, or until the loans are fully repaid, at which time such guarantees are released. In line with industry practice, we do not conduct independent credit checks on our customers but rely instead on the credit checks conducted by the mortgagee banks. As of December 31, 2010, 2011 and 2012, our outstanding guarantees on the mortgage loans of our purchasers amounted to RMB1,689.8 million, RMB2,478.8 million and RMB2,750.8 million (US\$441.5 million), respectively, which were approximately 11.0%, 13.7% and 11.2%, respectively, of our total assets, respectively. The default rates on the mortgage loans provided to the purchasers of our properties against the total guarantees we provided in connection with such mortgage loans were negligible during the three-year period ended December 31, 2012. If a purchaser defaults under the mortgage loan and the mortgagee bank calls on our relevant guarantee after it deals with the relevant property through a default auction, we are required to repay the outstanding amount owed by the purchaser to the mortgagee bank under the mortgage loan, the mortgagee bank will assign its rights under the loan and the mortgage to us and we have full recourse to the property. Our business, results of operations and financial condition could be materially and adversely affected to the extent that there is a material depreciation in the value of the mortgaged properties or if we are unable to re-sell such properties due to unfavorable market conditions or other reasons.

***Our results of operations may fluctuate from period to period***

Our results of operations tend to fluctuate from period to period. The number of properties that we can develop or complete during any particular period may be limited due to the substantial capital required for land acquisition and construction, as well as the lengthy development periods required before positive cash flows may be generated. In addition, several properties that we have developed or that are under development are large scale and are developed in multiple phases over the course of one to several years. The selling prices of the residential units in larger scale property developments tend to change over time, which may impact our sales proceeds and, accordingly, our revenues for any given period.

***Disputes with our joint venture or project development partners may materially and adversely affect our business***

We carry out some of our business through joint ventures or in collaboration with other third parties. Such joint venture arrangements or collaboration involve a number of risks, including:

- disputes with our partners in connection with the performance of their obligations under the relevant project, joint venture or cooperative property development agreements;
- disputes as to the scope of each party's responsibilities under these arrangements;
- financial difficulties encountered by our partners affecting their ability to perform their obligations under the relevant project, joint venture or cooperative property development agreements with us; or
- conflicts between the policies or objectives adopted by our partners and those adopted by us.

Any of these and other factors may materially and adversely affect our business.

***We may be required to forfeit land to the PRC government for failure to comply with the terms of the land grant contracts***

Under the PRC laws and regulations, if a property developer fails to develop land according to the terms of the land grant contract, including those relating to payment of fees, designated use of land and schedule for commencing and completing the developments, the relevant government authorities may issue a warning to or impose a penalty on the developer or require the developer to forfeit the land. Specifically, under current PRC laws and regulations, if property developers fail to commence development for more than one year from the commencement date stipulated in the land grant contract, the relevant PRC land bureau may serve a warning notice to the property developers and impose an idle land fee on the land of up to 20% of the land premium. If a property developer fails to commence development for more than two years from the commencement date stipulated in the land grant contract, the land may be subject to forfeiture to the PRC government. Moreover, even if the property developer commences the land development in accordance with the land grant contract, the relevant land will nonetheless be treated as idle land if (i) the developed GFA on the land is less than one-third of the total GFA of the project under the land grant contract or the total capital invested is less than one-fourth of the total estimated investment of the project under the land grant contract and (ii) the land development has been suspended for over one year without governmental approval. See "Regulation — I. Legal Supervision Relating to the Property Sector in the PRC — D. Development of a Property Project."

According to the Notice of Penalty on the Idleness of Land (閒置土地處置決定書) issued by the competent Land and Resources Bureau on December 15, 2011, Shenzhen Yuehua Innovation Technology Industry Company Limited received an administrative fine of approximately RMB0.6 million for the failure to commence development of a parcel of land within the period stipulated in the land grant contract. Except for the administrative penalty as disclosed above, during the years ended December 31, 2010, 2011 and 2012, we were not subject to any penalty for late payment of land premiums and were not required to forfeit any land nor have we received any warning from the relevant governmental authorities or paid any penalties as a result of failing to commence development within two years of the relevant land

grant contract. While we have complied with all development plans and payment obligations, there have been circumstances where the development of a portion of land for which our Group was granted land use rights was delayed beyond the date stipulated in the relevant land grant contract. As confirmed by relevant government authorities, in each case such delays were caused by force majeure, acts of government or preliminary work that was required to be undertaken prior to the commencement of development. According to relevant PRC laws and regulations, any delay in the commencement of development that can be attributed to any of the above factors will not result in the forfeiture of idle land and land grant deposits, or the imposition of any other penalty. Accordingly, Commerce & Finance Law Offices, our PRC legal counsel, are of the opinion that as of December 31, 2012, no such penalty had been imposed on us in respect of the above-mentioned delays. However, we cannot assure you that circumstances leading to forfeiture of land or delays in the completion of a property development may not arise in the future. If we are required to forfeit land, we will not be able to continue our property development on the forfeited land, recover the costs incurred for the initial acquisition of the forfeited land or recover development costs and other costs incurred up to the date of forfeiture.

***We are required to deliver individual property ownership certificates in a timely manner and the failure to do so may result in claims against us***

Property developers are typically required to deliver to purchasers the relevant individual property ownership certificates within one to two years after delivery of the property or within a time frame set out in the relevant sale and purchase agreement. Property developers, including us, generally elect to specify the deadline for the delivery of the individual property ownership certificates in the sale and purchase agreements to allow sufficient time for the application and approval processes. Under current regulations, property developers are required to submit requisite governmental approvals in connection with their property developments, including a land use rights certificate, a certificate evidencing the construction has met the requirements of relevant planning permits, a certificate evidencing the construction has completed, a property survey report, to the local bureau of land resources and housing administration after the receipt of the completion and acceptance certificate for the relevant properties and to apply for the general property ownership certificate in respect of these properties. Property developers are then required to submit, within regulated periods after delivery of the properties, the relevant property sale and purchase agreements, identification documents of the purchasers, proof for payment of deed tax, and the general property ownership certificate, to the bureau for review prior to the issuance of the individual property ownership certificates in respect of the properties purchased by the respective purchasers. Delays by the various administrative authorities in reviewing the application and granting approval as well as other factors may affect timely delivery of the general as well as individual property ownership certificates. Property developers, including us, may become liable for monetary penalties to purchasers for late delivery of the individual property ownership certificates due to delays in the administrative approval processes or for any other reason beyond our control. We cannot assure you that we will be able to timely deliver all property ownership certificates in the future or that we will not be subject to any liabilities as a result of any late deliveries of property ownership certificates.

***The relevant PRC tax authorities may challenge the basis on which we have been paying our LAT obligations and our results of operations and cash flows may be materially and adversely affected***

All income from the sale or transfer of state-owned land use rights, buildings and their attached facilities in the PRC is subject to the land appreciation tax (“LAT”) at progressive rates ranging from 30% to 60% of the “appreciated value of the property,” as such term is defined in the relevant tax laws. See “Regulation – I. Legal Supervision Relating to the Property Sector in the PRC – J. Major Taxes Applicable to Property Development Enterprises – (iii) Land Appreciation Tax.” There is an exemption for the sale of ordinary residential properties if the appreciated value does not exceed 20% of the total deductible expense items allowed under the relevant LAT regulations. This exemption is not available for sales of luxury residential properties, villas and commercial properties. It is not clear whether the residential portion of our mixed residential and commercial developments will be eligible for the exemption available to ordinary residential properties. In 2010, 2011 and 2012, we recorded a LAT expense in the amount of RMB440.8 million, RMB403.7 million and RMB580.1 million (US\$93.1 million), respectively, and we paid LAT in the amount of RMB99.5 million, RMB326.7 million and RMB244.6 million (US\$39.3 million), respectively.

On December 28, 2006, the State Administration of Taxation (the “SAT”) issued the LAT Notice, which became effective on February 1, 2007. The LAT Notice sets forth, among other things, methods of calculating LAT and a time frame for settlement of LAT. On May 12, 2009, the SAT issued the Provisions on Administration of the Settlement of Land Appreciation Tax (土地增值税清算管理規程), which became effective on June 1, 2009 and stipulates in detail the procedures for settlement of LAT and methods of calculating LAT. Furthermore, in May 2010, the SAT issued two notices emphasizing issues concerning (i) income verification in connection with the settlement of LAT; (ii) the calculation of applicable exemptions under certain circumstances; and (iii) the minimum LAT prepayment rate applicable to different types of properties in different localities. See “Regulation – I. Legal Supervision Relating to the Property Sector in the PRC – J. Major Taxes Applicable to Property Development Enterprises – (iii) Land Appreciation Tax.” We believe we have accrued all LAT payable on our property sales and transfers in accordance with the progressive rates specified in relevant PRC tax laws, less amounts previously paid under the levy method applied by relevant PRC local tax authorities. However, provisioning for LAT requires our management to use a significant amount of judgment with respect to, among other things, the anticipated total proceeds to be derived from the sale of the entire phase of the project or the entire project, the total appreciation of land value and the various deductible items. As a result, the relevant PRC local tax authorities may not agree with our estimates or the basis on which we calculate our LAT liabilities. If the LAT provisions we have made are substantially lower than the actual LAT amounts assessed by the relevant PRC local tax authorities in the future, our results of operations and cash flows will be materially and adversely affected.

***We are subject to multiple regulations of the PRC governmental authorities and any non-compliance or perceived non-compliance with these regulations may have a material and adverse effect on our business, financial condition and results of operations***

Our business is regulated by various PRC governmental authorities and departments. If any PRC authority believes that we or any of our suppliers or contractors in the course of our operations are not in compliance with PRC regulations, it could delay or even shut down our construction or sales operations, refuse to grant or renew any necessary approvals or licenses, institute legal proceedings to seize our properties, enjoin future actions or impose civil and/or criminal penalties, pecuniary or otherwise, against us, our officers or our employees. Any such action by the PRC governmental authorities would have a material adverse effect on our business, causing delays to our development projects, or terminating them altogether. In recent years, the PRC Government has implemented many new laws and regulations or made amendments to existing regulations concerning property developers. We cannot guarantee that our development projects are fully compliant with the laws and regulations. If we are found to have breached, or are accused of having not complied with, or in the future do not comply with, any applicable PRC laws and regulations, we may be subject to the imposition of penalties or even suspension of business and confiscation of any acquired land. In such event, our business and reputation may be materially and adversely affected.

***Our success depends on the continuing services of our senior management team and other key personnel***

Our future success depends heavily upon the continuing services of our executive directors and members of our senior management team, in particular, our chairman, executive director and chief executive officer, Mr. Pan and our executive director, Ms. Zeng. If one or more of our senior executives or other personnel are unable or unwilling to continue in their present positions, we may not be able to replace them easily or at all, and our business may be disrupted and our financial condition and results of operations may be materially and adversely affected. In addition, as competition in the PRC for senior management and key personnel with experience in property development is intense, and the pool of qualified candidates is very limited, we may not be able to retain the services of our senior executives or key personnel, or attract and retain high-quality senior executives or key personnel in the future. If we fail to attract and retain qualified personnel, our business and prospects may be adversely affected.

***We face competition for qualified employees in the property industry which may make it difficult for us to retain and recruit enough employees for the expansion of our business***

Our long-term success depends on our ability to attract and retain qualified employees. We require a large number of qualified employees for each stage of our property development process and for our property operation services, property agency services and hotel services businesses. We expect to recruit more qualified employees as we continue to strengthen our existing business or expand our business into new geographical regions and into other segments of the real estate industry. The growth of the property industry in China has created an increasing demand for qualified employees in each segment of the property industry. While we have implemented certain measures aimed to promote effective recruitment and retention of our employees, we cannot assure you that these measures will be effective. If we are unable to recruit or retain a sufficient number of qualified employees for the continuation and expansion of our business, our business and prospects may be adversely affected.

***We may suffer losses arising from uninsured risks***

In line with industry practice, we do not maintain insurance for destruction of or damage to our property developments (whether they are under development or have been completed and are pending delivery) other than with respect to those properties over which our lending banks have security interests, for which we are required to maintain insurance coverage under the relevant loan agreements. Similarly, we do not carry insurance covering construction-related personal injuries. In addition, we do not carry insurance for any liability arising from allegedly tortious acts committed on work sites. We cannot assure you that we would not be sued or held liable for damages due to such tortious acts. Moreover, there are certain losses for which insurance is not available on commercially practicable terms, such as losses suffered due to earthquake, typhoon, flooding, war and civil disorder. If we suffer from any losses, damages or liabilities in the course of our operations and property development, we may not have sufficient funds to cover any such losses, damages or liabilities or to replace any property development that has been destroyed. In addition, any payment we make to cover any losses, damages or liabilities may have a material adverse effect on our business, financial condition and results of operations.

***The total GFA of some of our property developments exceeds the original authorized area and the excess GFA is subject to governmental approval and payment of additional land premium***

When the PRC government grants the land use rights for a piece of land, it will specify in the land grant contract the designated use of the land and the total GFA that the developer may develop on this land. The actual GFA constructed, however, might have exceeded the total GFA authorized in the land grant contract due to various factors such as subsequent planning and design adjustments. The amount of GFA in excess of the authorized amount is subject to approval when the relevant authorities inspect the properties after their completion and the developer may be required to pay additional land premium in respect of such excess GFA. If we fail to obtain the completion certificate due to such excess GFA, we will not be allowed to deliver the relevant properties to the purchasers or recognize the revenue from the relevant pre-sold properties and may also be subject to liabilities under the pre-sale contracts. We cannot assure you that the total constructed GFA of our existing projects under development or any future property developments will not exceed the relevant authorized GFA upon completion or that we will be able to pay the additional land premium and obtain the completion certificate on a timely basis.

***The ancillary facilities in residential projects developed by us may not always be available to residents in the projects***

Many of the residential projects developed by us have ancillary facilities such as schools that enhance the value of properties in such projects by providing convenience and a better living environment to residents. We do not, however, own or operate any of these ancillary facilities except for clubhouses and therefore cannot guarantee that these ancillary facilities will continue to operate and provide services to residents in the properties developed by us. In the event that any of these ancillary facilities cease to operate and we cannot arrange for replacement services, properties in the affected project will become less attractive to potential purchasers, which will adversely affect our business to the extent that we have properties unsold or held for investment purposes in such project. In addition, our reputation may also be adversely affected as a result of the unavailability of such ancillary facilities.

***Our controlling shareholders may take actions that are not in, or may conflict with, our or our creditors', including the holders of the Notes, best interests***

As of December 31, 2012, our controlling shareholder, Fantasy Pearl International Limited (“Fantasy Pearl”) held 61.16% of our outstanding shares. Fantasy Pearl, and our ultimate controlling shareholders, Ms. Zeng Jie, Baby and Ice Apex Limited (“Ice Apex”), have and will continue to have the ability to exercise a controlling influence over our business, and may cause us to take actions that are not in, or may conflict with, our or our creditors', including the holders of the Notes, best interests, including matters relating to our management and policies and the election of our directors and senior management. Ms. Zeng Jie, Baby and Ice Apex will be able to influence our major policy decisions, including our overall strategic and investment decisions, by controlling the election of our directors and, in turn, indirectly controlling the selection of our senior management, determining the timing and amount of any dividend payments, approving our annual budgets, deciding on increases or decreases in our share capital, determining our issuance of new securities, approving mergers, acquisitions and disposals of our assets or businesses, and amending our articles of association. For more information, see “Management,” “Principal Shareholders,” and “Related Party Transactions.”

***We may be involved in legal and other proceedings arising out of our operations from time to time and may incur substantial losses and face significant liabilities as a result***

We may be involved in disputes with various parties involved in the development and sale of our properties, including business partners, contractors, suppliers, construction workers and purchasers. These disputes may lead to legal or other proceedings and may result in substantial costs, delays in our development schedule, and the diversion of resources and management's attention, regardless of the outcome. As most of our projects are developed in multiple phases, purchasers of our properties in earlier phases may file legal actions against us if our subsequent planning and development of the relevant project is perceived to be inconsistent with our representations and warranties made to such earlier purchasers. These disputes and legal and other proceedings may materially and adversely affect our reputation, business, results of operations and financial condition. The judicial process involved may decrease the time we devote to normal and customary operating functions. If we fail to resolve these disputes in our favor, we may incur substantial losses and face significant liabilities. We may also have disagreements with regulatory bodies in the course of our operations, which may subject us to administrative proceedings and unfavorable decisions that result in penalties and/or delay our property developments. Furthermore, if our PRC subsidiaries are not in full compliance with PRC laws and regulations, including those in relation to registered share capital, business licenses, operation permits and their articles of association, their operations may be adversely affected if they are subject to fines or sanctions imposed by PRC authorities as a result. In such cases, our results of operations and cash flow could be materially and adversely affected.

***We are subject to potential environmental liability that could result in substantial costs***

Property developers in the PRC are subject to a variety of laws and regulations concerning the protection of health and the environment. The particular environmental laws and regulations which apply to any given project development site vary greatly according to the location, the environmental condition and the present and former uses of the site, as well as adjacent properties. The relevant property development project may be delayed due to our efforts to comply with environmental laws and regulations may result in delays in development. In some environmentally sensitive regions or areas, the compliance costs could be prohibitively expensive. In addition, each property development project is required by the relevant PRC laws and regulations to undergo environmental assessments and to submit an environmental impact assessment report to the relevant government authorities for approval before commencement of construction. Failure to obtain such approval prior to construction may result in suspension of construction and a penalty amounting to RMB50,000 to RMB200,000 for each project.

The environmental investigations conducted relating to each of our property development projects to date have not revealed any material environmental liability. However, it is possible that these investigations did not reveal all environmental liabilities and there may be environmental liabilities of which we are unaware that may have a material adverse effect on our business, financial condition or results of operations. For additional information, see “Our Business — Environmental Matters.”

***The valuation attached to our property interests contains assumptions that may or may not materialize***

Under HKFRS, we are required to reassess the fair value of our completed investment properties at the date of every statement of financial position. Our valuations are generally based on a direct comparison approach, under which our investment properties are directly compared with other comparable properties of similar size, character and location, in order to provide a fair comparison of capital values, and an income approach by taking into account the net rental income of properties. Gains or losses arising from changes in the fair value of our investment properties are included in our consolidated statements of comprehensive income in the period in which they arise. Our investment properties were revalued as of December 31, 2010, 2011 and 2012, respectively, on an open market and existing use basis which reflected market conditions on those dates. The valuations are based on certain assumptions which, by their nature, are subjective and uncertain and may differ materially from actual results. For example, with respect to properties under development and planned for future development, the valuations are based on assumptions that (1) the properties will be developed and completed in accordance with the development proposals, (2) regulatory and governmental approvals for the proposals have been obtained, (3) all premiums in connection with the properties have been paid and the properties are free of encumbrances and other restrictions and (4) we are in possession of the proper legal titles and are entitled to transfer the properties at no extra land premium. For properties owned by the project companies in which we have an attributable interest of less than 100%, the valuation assumes that the interest of the relevant project companies in the aggregate value of the property or business is equal to our proportionate ownership interest in the relevant company or business. Accordingly, the valuations are not a prediction of the actual value we expect to realize from these properties. Unanticipated results or changes in particular property developments, or changes in general or local economic conditions or other relevant factors, including changes in government regulations, could affect such values.

***The construction business and the property development business are subject to claims under statutory quality warranties***

Under Regulations on the Administration of Quality of Construction Works (建設工程質量管理條例), all property development companies in the PRC must provide certain quality warranties for the properties they develop or sell. We are required to provide these warranties to our customers. We may sometimes receive quality warranties from our third-party contractors with respect to our development projects. If a significant number of claims are brought against us under our warranties and if we are unable to obtain reimbursement for such claims from third-party contractors in a timely manner or at all, we could incur significant expenses to resolve such claims or face delays in correcting the related defects, which could in turn harm our reputation and have a material and adverse effect on our business, financial condition and results of operations.

***We may be deemed a PRC resident enterprise under the EIT Law and be subject to the PRC taxation on our worldwide income***

The Enterprise Income Tax Law (“EIT Law”) and the implementation regulations to the EIT Law issued by the PRC State Council became effective on January 1, 2008. Under the EIT Law, enterprises established outside of China whose “de facto management bodies” are located in China are considered “resident enterprises” and will generally be subject to the uniform 25% enterprise income tax rate on their global income. It is, however, currently unclear under what situations an enterprise’s “de facto management body” would be considered to be located in China. The SAT promulgated the Circular on Identifying Chinese-Controlled Offshore Enterprises as Chinese Resident Enterprises in Accordance with Criteria for Determining Place of Effective Management (關於境外註冊中資控股企業依據實際管理機構標準認定為居民企業有關問題的通知) in April 2009 which defines the term “management body” in respect of enterprises that are established offshore by PRC enterprises. However, no definition of “management body” is provided for enterprises established offshore by private individuals or foreign enterprises like us. As such, Commerce & Finance Law Offices, our PRC legal counsel, has advised us that there is uncertainty whether we will be deemed to be a PRC “resident enterprise” for the purposes of the EIT Law. Substantially all of our management is currently based in China, and therefore, we may be treated as a PRC “resident enterprise” for enterprise income tax purposes. The tax consequences of such treatment are currently unclear, as they will depend on the implementation regulations and on how local tax authorities apply or enforce the EIT Law or the implementation regulations.

***We rely principally on dividends paid by our subsidiaries to fund any cash and financing requirements we may have; any limitation on the ability of our PRC subsidiaries to pay dividends to us could have a material adverse effect on our ability to conduct our business and such dividends may be subject to PRC taxation***

We are a holding company and rely principally on dividends paid by our subsidiaries for cash requirements, including the funds necessary to service any debt we may incur, including the Notes. The ability of our direct and indirect subsidiaries to pay dividends to their shareholders (including us, the Subsidiary Guarantors and the JV Subsidiary Guarantors, if any) is subject to applicable laws and restrictions contained in the debt instruments and obligations of such subsidiaries. Furthermore, under applicable PRC laws, rules and regulations, payment of dividends by our PRC subsidiaries is permitted only out of their retained earnings, if any, determined in accordance with PRC accounting standards. Under PRC laws, rules and regulations, all of our PRC subsidiaries are required to set aside at least 10% of their after-tax profit based on PRC accounting standards each year to their respective statutory capital reserve funds until the accumulative amount of such reserves reaches 50% of their respective registered capital. As a result, all of our PRC subsidiaries are restricted in their ability to transfer a portion of their net income to us whether in the form of dividends, loans or advances. As of December 31, 2012, our restricted reserves of the Group totaled RMB18.4 million (US\$3.0 million). Our restricted reserves are not distributable as cash dividends. Any limitation on the ability of our subsidiaries to pay dividends to us could materially and adversely limit our ability to grow, pay dividends or otherwise fund and conduct our business.

Under the EIT Law and implementation regulations issued by the State Council, a PRC income tax rate of 10% is applicable to dividends paid by Chinese enterprises to “non-resident enterprises,” subject to the application of any relevant income tax treaty that the PRC has entered into. As advised by Commerce & Finance Law Offices, our PRC legal counsel, there is uncertainty whether we or any of our non-PRC subsidiaries will be considered “non-resident enterprises” for the purposes of the EIT Law. If we or our non-PRC subsidiaries are considered “non-resident enterprises,” any dividend that we or any such subsidiary receive from our PRC subsidiaries may be subject to PRC taxation at the rate of 10% (or a lower treaty rate, if any), which would further impact the ability of our PRC subsidiaries to pay dividends to their shareholders (including us, the Subsidiary Guarantors and the JV Subsidiary Guarantors, if any).

## **Risks Relating to Our Industry**

***PRC government policies, regulations and measures intended to curtail the overheating of the property market may adversely affect our business***

Along with the economic growth in China, investments in the property sectors have increased significantly in the past few years. In response to concerns over the scale of the increase in property investments, the PRC government has introduced policies to curtail property development. On March 26, 2005, the General Office of the State Council promulgated the Circular on Duly Stabilizing the Prices of Residential Properties (關於切實穩定住房價格的通知) requiring measures to be taken to restrain the prices of residential properties from increasing too fast. On May 9, 2005, the General Office of the State Council approved the Opinion on Improving the Works on Stabilizing the Prices of Residential Properties (關於做好穩定住房價格工作的意見) issued by seven departments of the State Council, setting out guidelines for the relevant PRC authorities to control the rapid growth in the residential property market. On May 24, 2006, the General Office of the State Council approved the Opinions on Adjusting Housing Supply Structure and Stabilization of Housing Prices (關於調整住房供應結構穩定住房價格的意見) issued by nine departments of the State Council. On September 27, 2007, PBOC and CBRC issued the Notice on Strengthening the Management of Commercial Real Estate Credit and Loans (關於加強商業性房地產信貸管理的通知). These measures, among others, imposed various restrictions on lending funds to property developers and extending mortgage loans to property purchasers. These measures also provide that the total area of units with a GFA of less than 90 square meters must equal at least 70% of a residential housing project’s total GFA. On April 17, 2010, the State Council issued the Notice on Firmly Preventing Property Price from Increasing too rapidly in Certain Cities (國務院關於堅決遏制部分城市房價過快上漲的通知) (the “April 17 Notice”), pursuant to which the State Council raised the minimum down payment for second home purchases to 50% and set a minimum 30% down payment on first homes



with a GFA of more than 90 square meters. The notice also stipulates that interest rates for mortgage loans for second homes cannot be lower than 110% of PBOC benchmark lending rate. See “Regulation — I. Legal Supervision Relating to the Property Sector in the PRC — F. Property Credit.” We cannot assure you that the governmental authorities will not require us to modify our development plans or that these new measures will not adversely impact our business due to the uncertainties involved in implementing these new measures.

On July 11, 2006, the MOC, MOFCOM, the NDRC, the PBOC, SAIC and SAFE jointly issued the 171 Opinion which aims to regulate access by foreign investors to the domestic property market and to strengthen supervision over property purchases by foreign-invested enterprises. The 171 Opinion provides for, among other things, stricter standards for a foreign institution or an individual when purchasing real property in the PRC that is not intended for personal use. On May 23, 2007, MOFCOM and SAFE promulgated the Circular on Further Strengthening and Regulating the Approval and Supervision of Real Estate Industry with Direct Foreign Investment (關於進壹步加強、規範外商直接投資房地產業審批和監管的通知), or the “Notice 50,” which imposed additional restrictions and requirements on foreign investment in the real estate industry. See “Regulation — I. Legal Supervision Relating to the Property Sector in the PRC — B. Foreign-invested Property Enterprises.”

In accordance with the Notice on the Adjustment of Business Tax for the Sale of Individual Homes (關於調整個人住房轉讓營業稅政策的通知) revised by the Ministry of Finance of the People’s Republic of China (“MOF”) and the SAT on January 27, 2011, individuals who purchased their house for self-residential purposes may, five or more years after the purchase, resell their house without paying business tax. Individuals who have purchased their house for any purpose other than self-residential shall, if they owned it for five years or more, pay business tax on the net profit (the difference between the original price and the sales price). Individuals who have owned their house for less than five years shall pay business tax on the full sales price regardless of the purpose for which it was purchased. Such tax policy may curtail the market demand for residential properties and as a result, our business and future prospects may be materially and adversely affected.

In addition, on January 27, 2011, the governments of Shanghai and Chongqing issued their respective measures for implementing pilot property tax schemes, which became effective on January 28, 2011. According to the Circular Regarding the Opinion Concerning the Key Issues of Economic Structure Reform in 2012 (轉發關於2012年深化經濟體制改革重點工作意見的通知) issued by the State Council on March 18, 2012, the scope of such pilot property tax schemes shall be expanded to more cities or districts. Such new tax policies, once enacted, may further curtail the market demand for residential properties and as a result, our business and future prospects may be materially and adversely affected.

On February 20, 2013, the State Council announced five measures on the control of the PRC property market, including: (1) stabilizing property prices. Each major city in China is required to compile and announce its target for 2013 on how to control the prices of newly completed commodity properties; (2) strictly limiting speculative purchase of properties. Restrictions on purchasing commodity properties should be strictly implemented; expand the scope of experimental taxation against residential properties held by individuals; (3) increasing the supply of small to medium-sized commodity properties and lands; (4) accelerating the construction of housing for low-income individuals; and (5) strengthening the supervision of the property market.

On March 1, 2013, the State Council issued the Notice on Continuing Adjustment and Control of Property Markets (《關於繼續做好房地產市場調控工作的通知》) which, among other restrictive measures, provides that further restraining measures are to be adopted to strengthen the regulation of the real estate market. Major cities which have implemented the commodity housing purchase restrictions are required to enforce purchase restrictions in all administrative areas of cities and restricted housing are to include new commodity housing and second-hand housing. Non-local residents who have one or more residential property and fail to provide one-year or longer tax payment certificates or social insurance payment certificates will be barred from purchasing any residential properties located in the administrative areas subject to restrictions. For cities where housing prices are increasing at an excessively high rate, local branches of the PBOC may further raise the down-payment rate and mortgage interest rate for the purchase of a second residential property. In addition, the Notice stipulates that the state will strictly enforce a 20% tax on profits from sales of homes. Financial institutions, subject to

credit requirements being satisfied, will prioritize requests for mortgages for ordinary commodity housing construction projects in which medium and small housing units constitute 70% or more of the total units in such construction project.

Although the various control measures are intended to promote more balanced property development in the long term, we cannot assure you that these measures will not adversely affect the development and sales of our properties. In addition, although the PRC government has, due to the recent global financial and economic crisis, introduced an offsetting stimulus package, which included the reduction of deed taxes for first-time purchasers of ordinary residential property of less than 90 square meters, the waiver of stamp duty fees for individuals who are purchasing or selling ordinary residential properties, and the exemption of land appreciation tax for individuals who are selling ordinary residential properties, among other benefits, there is no assurance that such policy would remain and that the various control measures would not be re-implemented once the economy stabilizes, which may adversely affect our business, results of operations and financial condition.

***The PRC government has imposed restrictions on the ability of PRC property developers to receive offshore funds which may delay or prevent us from deploying the funds raised in this offering to our business in China and therefore materially and adversely affect our liquidity and our ability to fund and expand our business***

On July 10, 2007, the General Affairs Department of SAFE issued the Circular on Distribution of List of the First Group of Foreign-Invested Real Estate Projects Filed with the Ministry of Commerce (關於下發第一批通過商務部備案的外商投資房地產項目名單的通知), or the “SAFE notice.” The notice stipulates, among other things, (i) that SAFE will no longer process foreign debt registrations or applications for the purchase of foreign exchange submitted by real estate enterprises with foreign investment who obtained authorization certificates from and registered with MOFCOM on or after June 1, 2007 and (ii) that SAFE will no longer process foreign exchange registrations (or alteration of such registrations) or applications for the sale and purchase of foreign exchange submitted by real estate enterprises with foreign investment which obtained approval certificates from local government commerce departments on or after June 1, 2007 but which did not register with MOFCOM. This new regulation restricts the ability of foreign-invested real estate companies to raise funds offshore for the purpose of injecting such funds into the companies by way of shareholder loans. Nonetheless the SAFE notice does not restrict property developers from receiving foreign capital by way of increasing the registered capital of existing foreign-invested companies or through the establishment of new foreign-invested real estate companies, provided that such registered capital increase or new company establishment has been duly approved by local branches of MOFCOM and registered with MOFCOM or duly approved by MOFCOM.

Like other foreign-invested PRC property developers we are subject to the notice. We intend to repatriate any offshore funds that we may raise in the future by increasing the registered capital of our existing subsidiaries or by establishing new subsidiaries. Following the implementation of the SAFE notice, we have successfully remitted foreign funds from our offshore holding entities into a number of our PRC subsidiaries through increasing their respective registered capitals and registering each such increase with MOFCOM. However, we cannot assure you that we will be able to obtain in a timely manner, if at all, all necessary foreign-exchange approval certificates for the deployment of offshore funds, or that we will be able to obtain in a timely manner, if at all, any registration of new foreign-invested subsidiaries or additional registered capital increases in the future. Further, we cannot assure you that the PRC government will not introduce new policies that further restrict our ability to repatriate to China the funds raised in this offering. If we fail to repatriate to China any or all of the net proceeds raised in this offering, our liquidity and our ability to fund and expand our business could be adversely and materially affected.

In addition, any capital contributions made to our operating subsidiaries in China are also subject to the foreign investment regulations and foreign exchange regulations in the PRC. For example, in accordance with a circular promulgated by the SAFE in August 2008 with respect to the administration of conversion of foreign exchange capital contribution of foreign invested enterprises into Renminbi (關於完善外商投資企業外匯資本金支付結匯管理有關業務操作問題的通知), unless otherwise permitted by PRC laws or regulations, Renminbi capital converted from foreign exchange capital contribution can only be

applied to the activities within the approved business scope of such foreign-invested enterprise and cannot be used for domestic equity investment or acquisition. Pursuant to this offering memorandum, we may encounter difficulties in increasing the capital contribution to our project companies and subsequently converting such capital contribution into Renminbi for equity investment or acquisition in China. We cannot assure you that we will be able to obtain these approvals on a timely basis, or at all. If we fail to obtain such approvals, our ability to make capital contributions to our project companies as their general working capital or to fund their operations may be negatively affected, which could materially and adversely affect our results of operations.

***We are heavily dependent on the performance of the property market in China, which is at a relatively early stage of development***

The property development industry and the ownership of private property in the PRC are still in a relatively early stage of development. Although demand for private property in the PRC has been growing rapidly in recent years, such growth is often coupled with volatility in market conditions and fluctuation in property prices. It is extremely difficult to predict how much and when demand will develop, as many social, political, economic, legal and other factors, all of which are beyond our control, may affect market development. The level of uncertainty is increased by the limited availability of accurate financial and market information as well as the overall low level of transparency in the PRC.

The lack of a liquid secondary market for private property may discourage the acquisition of new properties as resale is not only difficult, but can also be a long and costly process. The limited amount of property mortgage financing available to PRC individuals, compounded by the lack of security of legal title and enforceability of property rights may inhibit demand for property developments, property operation services and property agency services.

***Increase in resettlement costs and the inability to reach resettlement agreements associated with certain property developments may materially and adversely affect our business, financial condition and results of operations***

Land parcels acquired by property developers for future development may have existing buildings or other structures or be occupied by third parties. In accordance with the Building on State-owned Land Expropriation and Compensation Regulation (國有土地上房屋徵收與補償條例) and applicable local regulations, a property developer in the PRC is required to enter into a written agreement with the owners or residents of existing buildings subject to demolition for development, directly or indirectly through the local government, and to provide compensation for their relocation and resettlement. The compensation payable by the property developer is calculated in accordance with a pre-set formula determined by the relevant provincial authorities, which may be subject to change. If such compensation formula is changed and the levels of compensation increased, land acquisition costs for property developers may be subject to substantial increases. In addition, if property developers or the local government fail to reach an agreement over compensation with the owners or residents of the buildings subject to demolition, any party may apply to the relevant housing resettlement authorities for a ruling on the amount of compensation, which may delay a project's timetable. Such delays may lead to an increase in cost and a delay in the expected cash inflow resulting from pre-sales of the relevant projects. If we experience an increase in resettlement costs or experience delay due to our inability to reach a resettlement agreement, our business, financial condition and results of operations may be materially and adversely affected.

## **Risks Relating to the PRC**

***Changes in PRC economic, political and social conditions, as well as government policies, could have a material adverse effect on our business, financial condition, results of operations and prospects***

Substantially all of our business and operations are conducted in China. Accordingly, our business, financial condition, results of operations and prospects are, to a significant degree, subject to economic, political and social developments in China. The Chinese economy differs from the economies of most developed countries in many respects, including the extent of government involvement, level of development, growth rate, control of foreign exchange and allocation of resources. Although the PRC government has implemented measures since the late 1970s emphasizing the utilization of market forces

for economic reform, the reduction of state ownership of productive assets and the establishment of improved corporate governance in business enterprises, a substantial portion of productive assets in China is still owned by the PRC government. In addition, the PRC government continues to play a significant role in regulating industry development by imposing industrial policies. The PRC government also exercises significant control over China's economic growth through allocation of resources, controlling payment of foreign currency denominated obligations, setting monetary policy and providing preferential treatment to particular industries or companies. Certain measures taken by the PRC government to guide the allocation of resources may benefit the overall economy of China but may, however, also have a negative effect on us. For example, our business, financial condition, results of operations and prospects may be adversely affected by government control over capital investments, changes in tax regulations that are applicable to us, change in interest rates and statutory reserve rates for banks or government control in bank lending activities.

***Uncertainties with respect to the PRC legal system could have a material adverse effect on us***

Our business and operations are primarily conducted in China and governed by PRC laws, rules and regulations. The PRC legal system is a civil law system based on written statutes. Prior court decisions may be cited for reference but have limited precedential value. Since the late 1970s, the PRC government has significantly enhanced PRC legislation and regulations to provide protection to various forms of foreign investments in China. However, China has not developed a fully integrated legal system and recently enacted laws and regulations may not sufficiently cover all aspects of economic activities in China. As many of these laws, rules and regulations are relatively new, and because of the limited volume of published decisions and their non-binding nature, the interpretation and enforcement of these laws, rules and regulations may involve uncertainties and may not be as consistent or predictable as in other more developed jurisdictions. Furthermore, the legal protections available to us under these laws, rules and regulations may be limited. Any litigation or regulatory enforcement action in China may be protracted and could result in substantial costs and diversion of resources and management attention.

***Fluctuation in the exchange rates of the Renminbi may have a material adverse effect on your investment***

The exchange rates between the Renminbi and the Hong Kong dollar, the U.S. dollar and other foreign currencies is affected by, among other things, changes in China's political and economic conditions. On July 21, 2005, the PRC government changed its decade-old policy of pegging the value of the Renminbi to the U.S. dollar. Under the new policy, the Renminbi is pegged against a basket of currencies, determined by the PBOC, against which it can rise or fall by as much as 0.5% each day. The floating band was further widened to 1.0% on April 16, 2012. These changes in policy resulted in the value of the Renminbi appreciating against the U.S. dollar by approximately 32.8% from July 21, 2005 to December 31, 2012.

There remains significant international pressure on the PRC government to adopt a more flexible currency policy, which could result in a further and more significant appreciation of the Renminbi against the U.S. dollar, the Hong Kong dollar or other foreign currency. As we rely on dividends paid to us by our operating subsidiaries, any significant revaluation of the Renminbi may have a material adverse effect on the value of dividends payable in foreign currency terms. To the extent that we need to convert the proceeds from this offering and future financing into the Renminbi for our operations, appreciation of the Renminbi against the relevant foreign currencies would have an adverse effect on the Renminbi amount we would receive from the conversion. Conversely, if we decide to convert our Renminbi into Hong Kong dollars for the purpose of making payments for dividends on our shares or for other business purposes, appreciation of the Hong Kong dollar against the Renminbi would have a negative effect on the Hong Kong dollar amount available to us.

***Governmental control over currency conversion may affect the value of your investment and limit our ability to utilize our cash effectively***

Substantially all of our revenue is denominated in Renminbi. The PRC government imposes controls on the convertibility of Renminbi into foreign currencies and, in certain cases, the remittance of currency out of China. Under existing PRC foreign exchange regulations, payments of current account items,

including profit distributions, interest payments and expenditures from trade-related transactions, can be made in foreign currencies without prior approval from SAFE by complying with certain procedural requirements. However, approval from SAFE or its local branch is required where Renminbi is to be converted into foreign currency and remitted out of China to pay capital expenses such as the repayment of loans denominated in foreign currencies. The PRC government may also at its discretion restrict access in the future to foreign currencies for current account transactions.

Under our current corporate structure, our income is primarily derived from dividend payments from our PRC subsidiaries. Shortages in the availability of foreign currency may restrict the ability of our PRC subsidiaries to remit sufficient foreign currency to pay dividends or other payments to us, or otherwise satisfy their foreign currency-denominated obligations. If the foreign exchange control system prevents us from obtaining sufficient foreign currency to satisfy our currency demands, we may not be able to pay dividends in foreign currencies to our shareholders. In addition, since a significant amount of our future cash flow from operations will be denominated in Renminbi, any existing and future restrictions on currency exchange may limit our ability to purchase goods and services outside of China or otherwise fund our business activities that are conducted in foreign currencies.

***Failure to comply with PRC regulations in respect of the registration of our PRC citizen employees' share options and restricted share units may subject such employees or us to fines and legal or administrative sanctions***

Pursuant to the Implementation Rules of the Administration Measure for Individual Foreign Exchange (個人外匯管理辦法實施細則) issued on January 5, 2007 by SAFE and relevant notice issued by SAFE in February 2012, PRC citizens who are granted shares or share options by an overseas listed company according to its employee share option or share incentive plan are required, through the PRC subsidiary of such overseas listed company or other qualified PRC agents, to obtain the approval of SAFE and complete certain other procedures related to the share options or other share incentive scheme. However, no requirements or administrative rules have been issued by SAFE in connection with the registration process for employees of overseas non-listed companies that participate in employee stock holding plans or stock option plans. In addition, foreign exchange income from the sale of shares or dividends distributed by the overseas listed company must be remitted into a foreign currency account of such PRC citizen or exchanged into Renminbi. Our PRC citizen employees who may be granted share options or restricted share units in the future, or our future PRC option holders, will be subject to the Individual Foreign Exchange Rules. If we or our future PRC option holders fail to comply with these regulations, we or our future PRC option holders may be subject to fines and legal or administrative sanctions.

***You may experience difficulty in effecting service of legal process, enforcing foreign judgments or bringing original actions in China based on foreign laws against us, our directors and our senior management***

We conduct substantially all of our operations in China and substantially all of our assets are located in China. In addition, the substantial majority of our directors and senior management reside within China. As a result, it may not be possible for investors to effect service of process outside China upon the substantial majority of our directors and senior management. Moreover, China does not have treaties with the United States, the United Kingdom or many other countries providing for the reciprocal recognition and enforcement of the judgment of courts. As a result, recognition and enforcement in China of judgments of a court in any of these jurisdictions may be difficult.

***The national and regional economies may be adversely affected by a recurrence of SARS or an outbreak of other epidemics, natural disasters or severe weather conditions, thereby affecting our business prospects***

In May 2008, a major earthquake and aftershocks struck Sichuan province in southwestern China. The epicenter was approximately 80 kilometers from Chengdu. In April 2013, another earthquake and aftershocks struck Sichuan province again and the epicenter was approximately 100 kilometers from Chengdu. We had 13 development projects comprised of three developed projects and 10 projects that were under development or held for future development in Chengdu. While none of these projects

suffered any material physical damages from the earthquake, some completed properties suffered minor damages such as cracks on the walls. While we do not have any legal liability to our customers for such damages as they were caused by the earthquake, which constitutes force majeure, we decided to repair such cracks for our customers at our own costs in order to increase our customer satisfaction and enhance our reputation as a responsible property developer. After the 2008 earthquake, construction of our projects in Chengdu was also suspended for about two months in compliance with orders issued by the local government that were applicable to all construction projects in Chengdu after the earthquake. Sale of our properties in Chengdu also dropped significantly during the few months after the 2008 earthquake. Our business could be materially adversely affected if any other natural disasters occur in the regions that we have business. In addition, certain areas of China are susceptible to epidemics, such as Severe Acute Respiratory Syndrome (“SARS”), the H1N1 influenza, also known as swine flu, or avian influenza, natural disasters or severe weather conditions. In April 2013, there were reports of cases of H7N9 avian flu in southeast China, including deaths in Shanghai. A recurrence of SARS, an outbreak of H1N1, H7N9 or avian influenza or any other epidemics, natural disasters or severe weather conditions in China could adversely affect the regional and national economies of Asia, including China, and could also result in material disruptions to our property developments and property related services and reduce the value of our investment properties, which in turn would adversely affect our financial condition and results of operations.

### **Risks Relating to the Notes**

***We are a holding company and payments with respect to the Notes are structurally subordinated to liabilities, contingent liabilities and obligations of our subsidiaries***

We are a holding company with no material operations. We conduct our operations through our PRC subsidiaries. The Notes will not be guaranteed by any current or future PRC subsidiaries. Our primary assets are ownership interests in our PRC subsidiaries, which are held through the Subsidiary Guarantors and certain Non-Guarantor Subsidiaries. The Subsidiary Guarantors do not, and the JV Subsidiary Guarantors (if any) may not, have material operations. Accordingly, our ability to pay principal and interest on the Notes and the ability of the Subsidiary Guarantors and the JV Subsidiary Guarantors (if any) to satisfy their obligations under the Subsidiary Guarantees or JV Subsidiary Guarantees (as the case may be) will depend upon our receipt of principal and interest payments on the intercompany loans and distributions of dividends from our subsidiaries.

Creditors, including trade creditors of Non-Guarantor Subsidiaries and any holders of preferred shares in such entities, would have a claim on the Non-Guarantor Subsidiaries’ assets that would be prior to the claims of holders of the Notes. As a result, our payment obligations under the Notes will be effectively subordinated to all existing and future obligations of our Non-Guarantor Subsidiaries, including their obligations under guarantees they have issued or will issue in connection with our business operations, and all claims of creditors of our Non-Guarantor Subsidiaries will have priority as to the assets of such entities over our claims and those of our creditors, including holders of the Notes. As of December 31, 2012, our PRC subsidiaries had unsubordinated indebtedness in the amount of RMB4,500.0 million (US\$722.2 million), capital commitments in the amount of RMB4,811.2 million (US\$772.2 million) and contingent liabilities arising from guarantees in the amount of RMB2,750.8 million (US\$441.5 million). The Notes and the Indenture permit us, the Subsidiary Guarantors, the JV Subsidiary Guarantors (if any) and our Non-Guarantor Subsidiaries to incur additional indebtedness and issue additional guarantees, subject to certain limitations. In addition, our secured creditors or those of any Subsidiary Guarantor or JV Subsidiary Guarantor (if any) would have priority as to our assets or the assets of such Subsidiary Guarantor or JV Subsidiary Guarantor (if any) securing the related obligations over claims of holders of the Notes.

Under the terms of the Notes, a Subsidiary Guarantee required to be provided by a subsidiary of the Company under the terms of the Notes may be replaced by a limited-recourse guarantee, or JV Subsidiary Guarantee, following the sale or issuance to a third party of a 20% to 49.9% equity interest in such subsidiary by its direct or indirect majority shareholders (subject to the satisfaction of certain conditions). Recovery under a JV Subsidiary Guarantee is limited to an amount equal to our proportional interest in the issued share capital of such Subsidiary Guarantor, or JV Subsidiary Guarantor, multiplied by the fair market value of the total assets in such JV Subsidiary Guarantor and its subsidiaries, on a

consolidated basis, as of the date of the last fiscal year end of the Company. As a result, the amount that may be recovered by the Trustee pursuant to a JV Subsidiary Guarantee (compared to a Subsidiary Guarantee) is reduced, which in turn may affect your ability to recover any amounts due under the Notes.

***We have substantial indebtedness and may incur substantial additional indebtedness in the future, which could adversely affect our financial health and our ability to generate sufficient cash to satisfy our outstanding and future debt obligations***

We now have, and will continue to have after the offering of the Notes, a substantial amount of indebtedness. Our total borrowings (including both current and non-current borrowings but excluding the 2010 Notes, the 2012 Notes and amounts due to related parties) as of December 31, 2010, 2011 and 2012 were RMB4,775.0 million, RMB4,741.0 million and RMB5,552.4 million (US\$891.2 million), respectively. We have also issued the January 2013 Notes in an aggregate amount of US\$250 million.

Our substantial indebtedness could have important consequences to you. For example, it could:

- limit our ability to satisfy our obligations under the Notes and other debt;
- increase our vulnerability to adverse general economic and industry conditions;
- require us to dedicate a substantial portion of our cash flow from operations to servicing and repaying our indebtedness, thereby reducing the availability of our cash flow to fund working capital, capital expenditures and for other general corporate purposes;
- limit our flexibility in planning for or reacting to changes in our businesses and the industry in which we operate;
- place us at a competitive disadvantage compared to our competitors that have less debt;
- limit, along with the financial and other restrictive covenants of our indebtedness, among other things, our ability to borrow additional funds; and
- increase the cost of additional financing.

In the future, we may from time to time incur substantial additional indebtedness and contingent liabilities. If we or our subsidiaries incur additional debt, the risks that we face as a result of our already substantial indebtedness and leverage could intensify.

Our ability to generate sufficient cash to satisfy our outstanding and future debt obligations will depend upon our future operating performance, which will be affected by prevailing economic conditions and financial, business and other factors, many of which are beyond our control. We anticipate that our operating cash flow will be sufficient to meet our anticipated operating expenses and to service our debt obligations as they become due. However, there is no assurance that we will be able to generate sufficient cash flow for these purposes. If we are unable to service our indebtedness, we will be forced to adopt an alternative strategy that may include actions such as reducing or delaying capital expenditures, selling assets, restructuring or refinancing our indebtedness or seeking equity capital. These strategies may not be instituted on satisfactory terms, if at all.

In addition, the terms of the Indenture prohibit us from incurring additional indebtedness unless (i) we are able to satisfy certain financial ratios or (ii) we are able to incur such additional indebtedness pursuant to any of the exceptions to the financial ratio requirements, and meet any other applicable restrictions. Our ability to meet our financial ratios may be affected by events beyond our control. We cannot assure you that we will be able to meet these ratios. Certain of our financing arrangements also impose operating and financial restrictions on our business. See the section entitled “Description of Material Indebtedness and Other Obligations.” Such restrictions in the Indenture and our other financing arrangements may negatively affect our ability to react to changes in market conditions, take advantage of business opportunities we believe to be desirable, obtain future financing, fund required capital expenditures, or withstand a continuing or future downturn in our business or the general economy. Any of these factors could materially and adversely affect our ability to satisfy our obligations under the Notes and other debt.

***Our subsidiaries are subject to restrictions on the payment of dividends and the repayment of intercompany loans or advances to us and our subsidiaries***

As a holding company, we depend on the receipt of dividends and the interest and principal payments on intercompany loans or advances from our subsidiaries, including our PRC subsidiaries, to satisfy our obligations, including our obligations under the Notes. The ability of our subsidiaries to pay dividends and make payments on intercompany loans or advances to their shareholders is subject to, among other things, distributable earnings, cash flow conditions, restrictions contained in the articles of association of our subsidiaries, applicable laws and restrictions contained in the debt instruments or agreements of such subsidiaries. In addition, if any of our subsidiaries raises capital by issuing equity securities to third parties, dividends declared and paid with respect to such equity securities would not be available to us to make payments on the Notes. These restrictions could reduce the amounts that we receive from our subsidiaries, which would restrict our ability to meet our payment obligations under the Notes and the obligations of the Subsidiary Guarantors or JV Subsidiary Guarantors (if any) under the Subsidiary Guarantees or JV Subsidiary Guarantees as the case may be.

PRC laws and regulations permit payment of dividends only out of accumulated profits as determined in accordance with PRC accounting standards and regulations and such profits differ from profits determined in accordance with HKFRS in certain significant respects, including the use of different bases of recognition of revenue and expenses. Our PRC subsidiaries are also required to set aside a portion of their after-tax profits according to PRC accounting standards and regulations to fund certain reserves that are not distributable as cash dividends. In addition, dividends paid by our PRC subsidiaries to their non-PRC parent companies are subject to a 10% withholding tax, unless there is a tax treaty between the PRC and the jurisdiction in which the overseas parent company is incorporated, which specifically exempts or reduces such withholding tax. Pursuant to an avoidance of double taxation arrangement between Hong Kong and the PRC, if the non-PRC parent company is a Hong Kong resident and directly holds a 25% or more interest in the PRC enterprise, such restrictions tax rate may be lowered to 5%. As a result of such restrictions, there could be timing limitations on payments from our PRC subsidiaries to meet payments required by the Notes or satisfy the obligations of the Subsidiary Guarantors or JV Subsidiary Guarantors (if any) under the Subsidiary Guarantees or JV Subsidiary Guarantees as the case may be, and there could be restrictions on payments required to redeem the Notes at maturity or as required for any early redemption.

Furthermore, although we currently do not have any offshore shareholder loan to our PRC subsidiaries, we may resort to such offshore lending in the future, rather than equity contribution, to our PRC subsidiaries to finance their operations. In such events, the market interest rates that our PRC subsidiaries can pay with respect to offshore loans generally may not exceed comparable interest rates in the international finance markets. The interest rates on shareholder loans paid by our subsidiaries, therefore, are likely to be lower than the interest rate for the Notes. Our PRC subsidiaries are also required to pay a 10% (or 7% if the interest is paid to a Hong Kong resident) withholding tax on our behalf on the interest paid under any shareholder loan. Prior to payment of interest and principal on any such shareholder loan, the PRC subsidiaries (as foreign-invested enterprises in China) must present evidence of payment of the withholding tax on the interest payable on any such shareholder loan and evidence of registration with SAFE, as well as any other documents that SAFE or its local branch may require.

As a result of the foregoing, we cannot assure you that we will have sufficient cash flow from dividends or payments on intercompany loans or advances from our subsidiaries to satisfy our obligations under the Notes or the obligations of the Subsidiary Guarantors or JV Subsidiary Guarantors (if any) under the Subsidiary Guarantees or JV Subsidiary Guarantees as the case may be.



### ***The Renminbi is not a freely convertible currency***

The Renminbi is not freely convertible at present. The PRC government continues to regulate conversion between Renminbi and foreign currencies, including the U.S. dollar and Hong Kong dollar, despite the significant reduction over the years by the PRC government of control over routine foreign exchange transactions under current accounts. Participating banks in Hong Kong have been permitted to engage in the settlement of Renminbi trade transactions under a pilot scheme introduced in July 2009. This represents a current account activity. The pilot scheme was extended in June 2010 to cover twenty provinces and cities in China and to make Renminbi trade and other current account item settlement available in all countries worldwide. On October 12, 2011, the MOFCOM promulgated the Circular on Issues Concerning Cross-Border Renminbi Direct Investment (Shang Zi Han 2011 No. 899) (《商務部關於跨境人民幣直接投資有關問題的通知》商資函[2011] 889號) (“MOFCOM Circular”) to further facilitate Renminbi inbound direct investments by foreign investors. On October 13, 2011, the PBOC promulgated the Administrative Measures on Settlement of Cross-Border Renminbi Direct Investment (PBOC Announcement 2011 No. 23) (《外商直接投資人民幣結算業務管理辦法》中國人民銀行公告[2011] 23號) (the “PBOC Measures”) to set forth rules for settlements of Renminbi inbound direct investments. The MOFCOM Circular and the PBOC Measures provide more detailed rules for cross-border Renminbi direct investments and settlements. See “Regulation — IV. General Legal Supervision in the PRC — Remittance of Renminbi into and outside the PRC.” We cannot assure you whether the relevant PRC authorities will adopt any other new regulations or rules to loosen or further strengthen the administration on the remittance of Renminbi for foreign direct investments.

### ***There is only limited availability of Renminbi outside China, which may affect the liquidity of the Notes and our ability to source Renminbi outside China to service the Notes***

As a result of the restrictions by the PRC government on cross-border Renminbi fund flows, the availability of Renminbi outside of China is limited.

Since February 2004, in accordance with arrangements between the PRC central government and the Hong Kong government, licensed banks in Hong Kong may offer limited Renminbi-denominated banking services to Hong Kong residents and specified business customers. The PBOC has also established a Renminbi clearing and settlement system for participating banks in Hong Kong. On July 19, 2010, further amendments were made to the Settlement Agreement on the Clearing of CNY Business (the “Settlement Agreement”) between the PBOC and Bank of China (Hong Kong) Limited (the “CNY Clearing Bank”) to further expand the scope of Renminbi business for participating banks in Hong Kong. Pursuant to the revised arrangements, all corporations are allowed to open Renminbi accounts in Hong Kong; there is no longer any limit on the ability of corporations to convert Renminbi; and there will no longer be any restriction on the transfer of Renminbi funds between different accounts in Hong Kong.

However, the current size of Renminbi-denominated financial assets outside China is limited. As of December 31, 2012, the total amount of Renminbi deposits held by institutions authorized to engage in Renminbi banking business in Hong Kong amounted to approximately RMB603 billion. In addition, participating banks are also required by the HKMA to maintain a total amount of Renminbi (in the form of cash and its settlement account balance with the CNY Clearing Bank) of no less than 25% of their Renminbi deposits, which further limits the availability of Renminbi that participating banks can utilise for conversion services for their customers. Renminbi business participating banks do not have direct Renminbi liquidity support from the PBOC. The CNY Clearing Bank only has access to onshore liquidity support from PBOC to square open positions of participating banks for limited types of transactions, including open positions resulting from conversion services for corporations in relation to cross-border trade settlement and for personal customers of up to RMB20,000 per person per day. The CNY Clearing Bank is not obliged to square for participating banks any open positions resulting from other foreign exchange transactions or conversion services. As a result the participating banks will need to source Renminbi from the offshore market to square such open positions.

Although it is expected that the offshore Renminbi market will continue to grow in depth and size, its growth is subject to many constraints as a result of PRC laws and regulations on foreign exchange. There is no assurance that new PRC regulations will not be promulgated in the future which have the effect of restricting availability of Renminbi offshore. The limited availability of Renminbi outside China

may affect the liquidity of the Notes. To the extent we are required to source Renminbi in the offshore market to service the Notes, there is no assurance that we will be able to source such Renminbi on satisfactory terms, if at all.

***Payment in respect of the Notes will only be made to investors in the manner specified in the Description of the Notes***

Except in the limited circumstance where the Renminbi is not available for delivery outside the PRC, all payment to investors in respect of the Notes will be made solely by (i) where the Notes are represented by a global certificate, transfer to a Renminbi bank account maintained in Hong Kong in accordance with prevailing CMU rules and procedures, or (ii) when the Notes are in definitive form, transfer to a Renminbi bank account maintained in Hong Kong in accordance with prevailing rules and regulations. We cannot be required to make payment by any other means (including in bank notes, by cheque or draft, or by transfer to a bank account in the PRC).

***Investment in the Notes may subject investors to foreign exchange rate risks***

The value of the Renminbi against the Hong Kong dollar and other foreign currencies fluctuates and is affected by changes in the PRC and international political and economic conditions and by many other factors. The Notes are denominated and payable in Renminbi. If an investor measures its investment returns by reference to a currency other than Renminbi, an investment in the Notes entails foreign exchange related risks, including possible significant changes in the value of Renminbi relative to the currency by reference to which an investor measures its investment returns. Depreciation of the Renminbi against such currency could cause a decrease in the effective yield of the Notes below their stated coupon rates and could result in a loss when the return on the Notes is translated into such currency. In addition, there may be tax consequences for investors as a result of any foreign currency gains resulting from any investment in the Notes.

***PRC regulation of loans to and direct investments in PRC entities by offshore holding companies may delay or prevent us from using the proceeds of this offering to make loans or additional capital contributions to our PRC operating subsidiaries***

According to the existing PRC rules and regulations relating to supervision of foreign debt, loans by foreign companies to their subsidiaries in China, such as our PRC subsidiaries established as foreign-invested enterprises in China, are considered foreign debt, and such loans must be registered with the relevant local branches of SAFE. Such rules and regulations also provide that the total outstanding amount of such foreign debt borrowed by any foreign-invested enterprise may not exceed the difference between its total investment and its registered capital, each as approved by the relevant PRC authorities. In addition, in July 2007, SAFE issued a circular indicating that it would not process any foreign debt registration or conversion of foreign debt for foreign-invested enterprises in the real estate sector that was approved by the local office of MOFCOM, and registered with MOFCOM after June 1, 2007. Foreign invested-enterprises include joint ventures and wholly foreign owned enterprises established in China, such as most of our PRC subsidiaries. Therefore, the proceeds of the current offering that will be used for land acquisitions and developments in China may only be transferred to our PRC subsidiaries as equity investments and not as loans. Equity contributions by us and our non-PRC subsidiaries to our PRC subsidiaries will require approvals from the commerce department of the local government and filing with MOFCOM and the local branch of SAFE, which may take considerable time and result in delays of receiving the contribution. This may in turn adversely affect the financial condition of the PRC subsidiaries and cause delays to the development undertaken by such PRC subsidiaries. We might not be able to obtain necessary approvals for our PRC subsidiaries at all.

The PRC government may introduce new policies that could further restrict our ability to use funds raised outside China. Our borrowings from sources outside of China as a percentage of our total borrowings has been increasing and may continue to increase in the future. Due to restrictions imposed by the PRC laws and regulations, we may not be able to use all or any of the funds that we raise outside of China, including the net proceeds from the current offering, as we contemplated, which may have a material and adverse effect on our business, results of operations, financial condition and prospects.

***We may not be able to repurchase the Notes upon a Change of Control Triggering Event***

We must offer to purchase the Notes upon the occurrence of a Change of Control Triggering Event, at a purchase price equal to 101% of the principal amount plus accrued and unpaid interest. See the section entitled “Description of the Notes.”

The source of funds for any such purchase would be our available cash or third-party financing. However, we may not have sufficient available funds at the time of the occurrence of any Change of Control Triggering Event to make purchases of outstanding Notes. Our failure to make the offer to purchase or to purchase the outstanding Notes would constitute an Event of Default under the Notes. The Event of Default may, in turn, constitute an event of default under other indebtedness, any of which could cause the related debt to be accelerated after any applicable notice or grace periods. If our other debt were to be accelerated, we may not have sufficient funds to purchase the Notes and repay the debt.

In addition, the definition of a Change of Control Triggering Event for purposes of the Indenture does not necessarily afford protection for the holders of the Notes in the event of some highly leveraged transactions, including certain acquisitions, mergers, refinancings, restructurings or other recapitalizations. These types of transactions could, however, increase our indebtedness or otherwise affect our capital structure or credit ratings. The definition of Change of Control Triggering Event for purposes of the Indenture also includes a phrase relating to the sale of “all or substantially all” of our assets. Although there is a limited body of case law interpreting the phrase “substantially all,” there is no precise established definition under applicable law. Accordingly, our obligation to make an offer to purchase the Notes and the ability of a holder of the Notes to require us to purchase its Notes pursuant to the offer as a result of a highly leveraged transaction or a sale of less than all of our assets may be uncertain.

***Interest payable by us to our foreign investors and gain on the sale of our Notes may be subject to withholding taxes under PRC tax laws***

Under the EIT Law, if our Company is deemed a PRC resident enterprise, the interest payable on the Notes may be considered to be sourced within China. In that case, PRC income tax at the rate of 10% will be withheld from interest paid by us to investors that are “non-resident enterprises” so long as such “non-resident enterprise” investors do not have an establishment or place of business in China or, if despite the existence of such establishment or place of business in China, the relevant income is not effectively connected with such establishment or place of business in China. Any gain realized on the transfer of the Notes by such investors will be subject to a 10% PRC income tax if such gain is regarded as income derived from sources within China. It is uncertain whether we will be considered a PRC “resident enterprise.” If we are required under the EIT Law to withhold PRC income tax on our interest payable to our foreign shareholders that are “non-resident enterprises,” we will be required to pay such additional amounts as will result in receipt by a holder of a Note of such amounts as would have been received by the holder had no such withholding been required. The requirement to pay additional amounts will increase the cost of servicing interest payments on the Notes, and could have a material adverse effect on our ability to pay interest on, and repay the principal amount of, the Notes, as well as our profitability and cash flow. In addition, if you are required to pay PRC income tax on the transfer of our Notes, the value of your investment in our Notes may be materially and adversely affected. It is unclear whether, if we are considered a PRC “resident enterprise,” holders of our Notes might be able to claim the benefit of income tax treaties or agreements entered into between China and other countries or areas.

***We may be able to redeem the Notes in whole at a redemption price equal to 100% of the principal amount plus accrued and unpaid interest in the event we are required to pay additional amounts because we are treated as a PRC “resident enterprise”***

In the event we are treated as a PRC “resident enterprise” under the EIT Law, we may be required to withhold PRC tax on interest payable to certain of our non-resident investors. In such case, we will, subject to certain exceptions, be required to pay such additional amounts as will result in receipt by a holder of a Note of such amounts as would have been received by the holder had no such withholding been required. As described under “Description of the Notes — Redemption for Taxation Reasons,” in the event we are required to pay additional amounts as a result of certain changes in specified tax law or

certain other circumstances, including any change or interpretation that results in our being required to withhold tax on interest payments as a result of our being treated as a PRC “resident enterprise,” we may redeem the Notes in whole at a redemption price equal to 100% of the principal amount plus accrued and unpaid interest.

***The insolvency laws of the Cayman Islands and other local insolvency laws may differ from U.S. bankruptcy law or those of another jurisdiction with which holders of the Notes are familiar***

Because we and some of the Subsidiary Guarantors are incorporated, and the JV Subsidiary Guarantors (if any) may be incorporated, under the laws of the Cayman Islands, an insolvency proceeding relating to us or any such Subsidiary Guarantor or JV Subsidiary Guarantor, even if brought in the United States, would likely involve Cayman Islands insolvency laws, the procedural and substantive provisions of which may differ from comparable provisions of United States federal bankruptcy law. In addition, our other Subsidiary Guarantors and JV Subsidiary Guarantors (if any) are incorporated or may be incorporated in the BVI or Hong Kong and the insolvency laws of the BVI and Hong Kong may also differ from the laws of the United States or other jurisdictions with which the holders of the Notes are familiar.

We conduct substantially all of our business operations through PRC-incorporated subsidiaries in China. The Subsidiary Guarantors, as equity holders in our PRC subsidiaries, are necessarily subject to the bankruptcy and insolvency laws of China in a bankruptcy or insolvency proceeding involving any of such PRC subsidiaries. Any JV Subsidiary Guarantors which become equity holders of our PRC subsidiaries would also be subject to such laws. The PRC laws and regulations relating to bankruptcy and insolvency and the legal proceedings in that regard may significantly differ from those of the United States and other jurisdictions with which the holders of the Notes are familiar. You should analyze the risks and uncertainties carefully before you invest in our Notes.

***We may be unable to obtain and remit foreign exchange***

Our ability to satisfy our obligations under the Notes depends solely upon the ability of our PRC subsidiaries to obtain and remit sufficient foreign currency to pay dividends to us and, if applicable, to repay shareholder loans. Our PRC subsidiaries must present certain documents to SAFE, its authorized branch, or the designated foreign exchange bank, for approval before they can obtain and remit foreign currencies out of China, including, in the case of dividends, evidence that the relevant PRC taxes have been paid and, in the case of shareholder loans, evidence of the registration of the loan with SAFE. Prior to payment of interest and principal on any shareholder loan we make to our PRC subsidiaries, the relevant PRC subsidiary must also present evidence of payment of the 10% (or 7% if the interest is paid to a Hong Kong resident) withholding tax on the interest payable in respect of such shareholder loan. If any PRC subsidiary for any reason fails to satisfy any of the PRC legal requirements for remitting foreign currency payments, the PRC subsidiary will be unable to pay us dividends or interest and principal on shareholder loans, which may affect our ability to satisfy our obligations under the Notes.

***If we are unable to comply with the restrictions and covenants in our debt agreements or the Indenture, there could be a default under the terms of these agreements or the Indenture, which could cause repayment of our debt to be accelerated***

If we are unable to comply with the restrictions and covenants in the Indenture or our current or future debt obligations and other agreements, there could be a default under the terms of these agreements. In the event of a default under these agreements, the holders of the debt could terminate their commitments to lend to us, accelerate repayment of the debt and declare all outstanding amounts due and payable or terminate the agreements, as the case may be. Furthermore, some of our debt agreements, including the Indenture, contain cross-acceleration or cross-default provisions. As a result, our default under one debt agreement may cause the acceleration of repayment of not only such debt but also other debt, including the Notes, or result in a default under our other debt agreements, including the Indenture. If any of these events occur, we cannot assure you that our assets and cash flow would be sufficient to repay in full all of our indebtedness, or that we would be able to find alternative financing. Even if we could obtain alternative financing, we cannot assure you that it would be on terms that are favorable or acceptable to us.

***Our operations are restricted by the terms of the Notes, which could limit our ability to plan for or to react to market conditions or meet our capital needs, which could increase your credit risk***

The Indenture includes a number of significant restrictive covenants. These covenants restrict, among other things, our ability, and the ability of our Restricted Subsidiaries, to:

- incur or guarantee additional indebtedness and issue disqualified or preferred stock;
- declare dividends on capital stock or purchase or redeem capital stock;
- make investments or other specified restricted payments;
- issue or sell capital stock of Restricted Subsidiaries;
- guarantee indebtedness of Restricted Subsidiaries;
- sell assets;
- create liens;
- enter into sale and leaseback transactions;
- engage in any business other than permitted business;
- enter into agreements that restrict the Restricted Subsidiaries' ability to pay dividends, transfer assets or make intercompany loans;
- enter into transactions with shareholders or affiliates; and
- effect a consolidation or merger.

These covenants could limit our ability to plan for or react to market conditions or to meet our capital needs. Our ability to comply with these covenants may be affected by events beyond our control, and we may have to curtail some of our operations and growth plans to maintain compliance.

***A trading market for the Notes may not develop, and there are restrictions on resale of the Notes***

The Notes are a new issue of securities for which there is currently no trading market. Although we have received approval in-principle for the listing and quotation of the Notes on the Official List of the SGX-ST, we cannot assure you that we will obtain or be able to maintain a listing on the Official List of the SGX-ST, or that, even if listed, a liquid trading market will develop. We have been advised that the Initial Purchasers intend to make a market in the Notes, but the Initial Purchasers are not obligated to do so and may discontinue such market making activity at any time without notice. In addition, the Notes are being offered pursuant to exemptions from registration under the U.S. Securities Act and, as a result, you will only be able to resell your Notes in transactions that have been registered under the U.S. Securities Act or in transactions not subject to or exempt from registration under the U.S. Securities Act. See the section entitled "Transfer Restrictions." No assurance can be given as to the liquidity of, or the development and continuation of an active trading market for the Notes. If an active trading market does not develop or is not continued, the market price and liquidity of the Notes could be adversely affected.

***The ratings assigned to the Notes and our corporate ratings may be lowered or withdrawn in the future***

The Notes have been assigned a rating of B+ by Standard and Poor's Ratings Services and B2 by Moody's Investors Service. The ratings address our ability to perform our obligations under the terms of the Notes and credit risks in determining the likelihood that payments will be made when due under the Notes. In addition, we have been assigned a long-term corporate credit rating of BB- with a stable outlook by Standard and Poor's Rating Services and a corporate family rating of B1 with a stable outlook by

Moody's Investors Service. A rating is not a recommendation to buy, sell or hold securities and may be subject to revision, suspension or withdrawal at any time. We cannot assure you that a rating will remain for any given period of time or that a rating will not be lowered or withdrawn entirely by the relevant rating agency if in its judgment circumstances in the future so warrant. We have no obligation to inform holders of the Notes of any such revision, downgrade or withdrawal. A suspension, reduction or withdrawal at any time of the rating assigned to the Notes may adversely affect the market price of the Notes.

***Certain transactions that constitute "connected transactions" under the Listing Rules will not be subject to the "Limitation on Transactions with Shareholders and Affiliates" covenant***

Our shares are listed on the Hong Kong Stock Exchange and we are required to comply with its Listing Rules, which provide, among other things, that any transaction between a listed company or any of its subsidiaries, on the one hand, and a "connected person" of such listed company, on the other hand, is a "connected transaction" that, if the value of such transaction exceeds the applicable de minimis thresholds, will require the prior approval of the independent shareholders of such listed company. The definition of "connected person" to a listed company includes, among others, any 10% or more shareholder of (i) such listed company or (ii) any subsidiary of such listed company. The concept of "connected person" also captures "associates," which include, among others, (a) any subsidiary of such "connected person," (b) any holding company of such "connected person" and any subsidiary of such holding company, and (c) any company in which such entity or entities mentioned in (a) and (b) above taken together has/have the power to exercise control, directly or indirectly, of 30% or more of the voting power of such company.

The "Limitation on Transactions with Shareholders and Affiliates" covenant in the Notes only applies to transactions between the Company or any Restricted Subsidiary, on the one hand, and (x) any holder (or any Affiliate of such holder) of 10% or more of the shares of the Company or (y) any Affiliate of the Company, on the other hand. As such, transactions between the Company or any Restricted Subsidiary, on the one hand, and an Affiliate of any Restricted Subsidiary, on the other hand, will not be captured by such covenant, even though they are subject to the independent shareholders' requirement under the Listing Rules. As a result, we are not required by the terms of the Notes to ensure that any such transactions are on terms that are fair and reasonable, and we will not need to deliver officers' certificates or procure the delivery of fairness opinions of accounting, appraisal or investment banking firms to the trustee of the Notes for any such transactions.

***The liquidity and price of the Notes following the offering may be volatile***

The price and trading volume of the Notes may be highly volatile. Factors such as variations in our revenues, earnings and cash flows, proposals for new investments, strategic alliances and/or acquisitions, changes in interest rates, fluctuations in price for comparable companies, government regulations and changes thereof applicable to our industry and general economic conditions nationally or internationally could cause the price of the Notes to change. Any such developments may result in large and sudden changes in the trading volume and price of the Notes. We cannot assure you that these developments will not occur in the future.

***There may be less publicly available information about us than is available in certain other jurisdictions***

There may be less publicly available information about companies listed in Hong Kong than is regularly made available by public companies in certain other countries. In addition, the financial information in this offering memorandum has been prepared in accordance with HKFRS, which differ in certain respects from generally accepted accounting principles in other jurisdictions, or other GAAPs, which might be material to the financial information contained in this offering memorandum. We have not prepared a reconciliation of our consolidated financial statements and related footnotes between HKFRS and other GAAPs. In making an investment decision, you must rely upon your own examination of us, the terms of the offering and our financial information. You should consult your own professional advisers for an understanding of the differences between HKFRS and other GAAPs and how those differences might affect the financial information contained in this offering memorandum.

***We will follow the applicable corporate disclosure standards for debt securities listed on the Official List of the SGX-ST, which standards may be different from those applicable to companies in certain other countries***

We will be subject to reporting obligations in respect of the Notes to be listed on the Official List of the SGX-ST. The disclosure standards imposed by the SGX-ST may be different than those imposed by securities exchanges in other countries or regions such as the United States or Hong Kong. As a result, the level of information that is available may not correspond to what investors in the Notes are accustomed to.

### **Risks Relating to the Subsidiary Guarantees, the JV Subsidiary Guarantees and the Collateral**

***Our initial Subsidiary Guarantors do not currently have significant operations and certain Subsidiary Guarantees may in some cases be replaced by limited-recourse guarantees***

We conduct substantially all of our business operations through our PRC subsidiaries, but none of our current PRC subsidiaries and their direct PRC or non-PRC subsidiaries will provide a Subsidiary Guarantee or a JV Subsidiary Guarantee either upon issuance of the Notes or at any time thereafter. No future subsidiaries that are organized under the laws of PRC or their future PRC or non-PRC subsidiaries will provide a Subsidiary Guarantee or a JV Subsidiary Guarantee at any time in the future. As a result, the Notes will be effectively subordinated to all the debt and other obligations, including contingent obligations and trade payables, of the PRC subsidiaries. See the section entitled “Description of the Notes — The Subsidiary Guarantees” for a list of the Non-Guarantor Subsidiaries. Moreover, the charge over the shares of the offshore subsidiaries of the Company (the “Collateral”) will not include the capital stock of our existing or future Non-Guarantor Subsidiaries, including our PRC subsidiaries.

The initial Subsidiary Guarantors that will guarantee the Notes do not have significant operations. We cannot assure you that the initial Subsidiary Guarantors or any subsidiaries that may become Subsidiary Guarantors or JV Subsidiary Guarantors in the future will have the funds necessary to satisfy our financial obligations under the Notes if we are unable to do so. See the section entitled “— Risks Relating to the Notes — We are a holding company and payments with respect to the Notes are structurally subordinated to liabilities, contingent liabilities and obligations of our subsidiaries.”

Under the terms of the Notes, a Subsidiary Guarantor may be able to release its Subsidiary Guarantee if it sells or issues more than 20% of the capital stock of such Subsidiary Guarantor to a third party, as long as the consolidated assets of all Restricted Subsidiaries organized outside the PRC that are not Subsidiary Guarantors or JV Subsidiary Guarantors do not account for more than 20% of our total assets.

In addition, a Subsidiary Guarantee required to be provided by a subsidiary of the Company under the terms of the Notes may be replaced by a limited-recourse JV Subsidiary Guarantee following the sale or issuance to a third party of a minority interest in such subsidiary or its direct or indirect majority shareholders (subject to the satisfaction of certain conditions including a cap on the non-guaranteed portion of the assets of JV Subsidiary Guarantors). Recovery under a JV Subsidiary Guarantee is limited to an amount equal to our proportional interest in the issued share capital of such JV Subsidiary Guarantor multiplied by the fair market value of the total assets in such JV Subsidiary Guarantor and its subsidiaries, on a consolidated basis, as of the date of the last fiscal year end of the Company.

***The Subsidiary Guarantees or JV Subsidiary Guarantees may be challenged under applicable insolvency or fraudulent transfer laws, which could impair the enforceability of the Subsidiary Guarantees or JV Subsidiary Guarantees***

Under bankruptcy laws, fraudulent transfer laws, insolvency or unfair preference or similar laws in the Cayman Islands, the BVI, Hong Kong and other jurisdictions where future Subsidiary Guarantors or JV Subsidiary Guarantors (if any) may be established, a guarantee could be voided, or claims in respect of a guarantee could be subordinated to all other debts of that guarantor if, among other things, the guarantor, at the time it incurred the indebtedness evidenced by, or when it gives, its guarantee:

- incurred the debt with the intent to hinder, delay or defraud creditors or was influenced by a desire to put the beneficiary of the guarantee in a position which, in the event of the guarantor’s insolvency, would be better than the position the beneficiary would have been in had the guarantee not been given;

- received less than reasonably equivalent value or fair consideration for the incurrence of such guarantee;
- was insolvent or rendered insolvent by reason of the incurrence of such guarantee;
- was engaged in a business or transaction for which the guarantor's remaining assets constituted unreasonably small capital; or
- intended to incur, or believed that it would incur, debts beyond its ability to pay such debts as they mature.

The measure of insolvency for purposes of the foregoing will vary depending on the laws of the applicable jurisdiction. Generally, however, a guarantor would be considered insolvent at a particular time if it were unable to pay its debts as they fell due or if the sum of its debts was then greater than all of its properties at a fair valuation or if the present fair saleable value of its assets was then less than the amount that would be required to pay its probable liabilities in respect of its existing debts as they became absolute and matured.

In addition, a guarantee may be subject to review under applicable insolvency or fraudulent transfer laws in certain jurisdictions or subject to a lawsuit by or on behalf of creditors of the guarantor. In such case, the analysis set forth above would generally apply, except that the guarantee could also be subject to the claim that, since the guarantee was not incurred for the benefit of the guarantor, the obligations of the guarantor thereunder were incurred for less than reasonably equivalent value or fair consideration.

In an attempt to limit the applicability of insolvency and fraudulent transfer laws in certain jurisdictions, the obligations of the Subsidiary Guarantors or JV Subsidiary Guarantors (if any) under the Subsidiary Guarantees or JV Subsidiary Guarantees (as the case may be) will be limited to the maximum amount that can be guaranteed by the applicable Subsidiary Guarantor or JV Subsidiary Guarantor without rendering the guarantee, as it relates to such Subsidiary Guarantor or JV Subsidiary Guarantor, voidable under such applicable insolvency or fraudulent transfer laws.

If a court voids a Subsidiary Guarantee or JV Subsidiary Guarantee (as the case may be), subordinates such guarantee to other indebtedness of the Subsidiary Guarantor or JV Subsidiary Guarantor, or holds the Subsidiary Guarantee or JV Subsidiary Guarantee (as the case may be) unenforceable for any other reason, holders of the Notes would cease to have a claim against that Subsidiary Guarantor or JV Subsidiary Guarantor based upon such guarantee, would be subject to the prior payment of all liabilities (including trade payables) of such Subsidiary Guarantor or JV Subsidiary Guarantor (as the case may be), and would solely be creditors of us and any Subsidiary Guarantors or JV Subsidiary Guarantors whose guarantees have not been voided or held unenforceable. We cannot assure you that, in such an event, after providing for all prior claims, there would be sufficient assets to satisfy the claims of the holders of the Notes.

***The pledge of certain Collateral may in some circumstances be voidable***

The pledge of the Collateral may be voidable as a preference under insolvency or fraudulent transfer or similar laws of Hong Kong, the Cayman Islands and the BVI at any time within six months of the perfection of the pledge or, under some circumstances, within a longer period. Pledges of capital stock of future Subsidiary Guarantors may also be voidable as a preference under relevant insolvency or fraudulent transfer or similar laws. In addition, the pledge of certain Collateral may be voided based on the analysis set forth under the section entitled “— The Subsidiary Guarantees or JV Subsidiary Guarantees may be challenged under applicable insolvency or fraudulent transfer laws, which could impair the enforceability of the Subsidiary Guarantees or JV Subsidiary Guarantees” above.

If the pledges of the Collateral were to be voided for any reason, holders of the Notes would have only an unsecured claim against us and the Subsidiary Guarantor Pledgors.



***The value of the Collateral is unlikely to be sufficient to satisfy our obligations under the Notes and other pari passu secured indebtedness***

The Collateral will consist only of the capital stock of certain initial Subsidiary Guarantors. The security interest in respect of certain Collateral may be released upon the disposition of such Collateral and any proceeds from such disposition may be applied, prior to repaying any amounts due under the Notes, to repay other debt or to make investments in properties and assets that will not be pledged as additional Collateral.

The ability of the Trustee, on behalf of the holders of the Notes, to foreclose on the Collateral upon the occurrence of an Event of Default or otherwise will be subject in certain instances to perfection and priority status. Although procedures will be undertaken to support the validity and enforceability of the security interests, we cannot assure you that the Trustee or holders of the Notes will be able to enforce the security interest.

The value of the Collateral in the event of a liquidation will depend upon market and economic conditions, the availability of buyers and similar factors. No independent appraisals of any of the Collateral have been prepared by or on behalf of us in connection with this offering of the Notes. Accordingly, we cannot assure you that the proceeds of any sale of the Collateral following an acceleration of the Notes would be sufficient to satisfy, or would not be substantially less than, amounts due and payable on the Notes. By its nature, the Collateral, which consists solely of the capital stock of any existing or future Subsidiary Guarantor, is likely to be illiquid and is unlikely to have a readily ascertainable market value. Likewise, we cannot assure you that the Collateral will be saleable or, if saleable, that there will not be substantial delays in its liquidation.

The Collateral will be shared on a *pari passu* basis by the holders of the Notes, the 2010 Notes, the 2012 Notes and the January 2013 Notes and may be shared on a *pari passu* basis with holders of other indebtedness ranking *pari passu* with the Notes that we may issue in the future. Accordingly, in the event of a default on the Notes or the other secured indebtedness and a foreclosure on the Collateral, any foreclosure proceeds would be shared by the holders of secured indebtedness in proportion to the outstanding amounts of each class of such secured indebtedness. The value of the Collateral securing the Notes and the Subsidiary Guarantees of the Subsidiary Guarantor Pledgors is unlikely to be sufficient to satisfy the obligations of the Company and each of the Subsidiary Guarantor Pledgors under the Notes and the Subsidiary Guarantees of the Subsidiary Guarantor Pledgors, and the Collateral securing the Notes and such Subsidiary Guarantees may be reduced or diluted under certain circumstances, including the issuance of Additional Notes or other *pari passu* indebtedness and the disposition of assets comprising the Collateral, subject to the terms of the Indenture.

***The pledge of certain Collateral may be released under certain circumstances***

In the event the conditions applicable to the replacement of a Subsidiary Guarantee with a JV Subsidiary Guarantee are satisfied, we are permitted to release the pledge of the shares granted by such Subsidiary Guarantor, as well as the pledge of the shares granted by the subsidiaries of such Subsidiary Guarantor. We are only required to deliver a replacement share pledge for the shares that we continue to hold in such JV Subsidiary Guarantor (but not the subsidiaries of such JV Subsidiary Guarantor) following the sale of the equity interests in such Subsidiary Guarantor. As a result, in the event we sell minority equity interests in our Subsidiary Guarantors or otherwise create JV Subsidiary Guarantors in accordance with the terms of the Indenture, the Collateral will be reduced in value and scope, and holders of the Notes would be subject to increased risks.

***The Intercreditor Agreement may impact the ability of the Company and the Subsidiary Guarantors to pay amounts due under the Notes and the Subsidiary Guarantees and the Intercreditor Agreement may limit the rights of holders of the Notes to the Collateral***

The Collateral Agent (as defined under “Description of the Notes — Definitions”) is required to take action to enforce the Collateral in accordance with the instructions of the holders of the Notes, the holders of the 2010 Notes, the holders of the 2012 Notes, the holders of the January 2013 Notes and holders (or representatives or agents) of other Permitted Pari Passu Secured Indebtedness (as defined

under “Description of the Notes — Definitions”), given under and in accordance with the Intercreditor Agreement. Any enforcement action taken by the Collateral Agent will adversely affect the Company’s entitlement to receive distributions from the Collateral, which will, in turn, have an adverse impact on the Company’s ability to fulfill its payment obligations under the Notes. Further, the Subsidiary Guarantors’ ability to pay under the Subsidiary Guarantees will be adversely affected. The ability of holders of the Notes to enforce the Collateral is restricted under the Intercreditor Agreement, as only the Collateral Agent is permitted to take enforcement actions. If an event of default occurs under the Notes, the holders of the Notes holding 25% of the outstanding amount of the Notes and holders, creditors or representatives of the 2010 Notes, the 2012 Notes, the January 2013 Notes and other Permitted Pari Passu Secured Indebtedness may decide whether to take any enforcement action and may thereafter, through their respective trustee, representative or agent, in accordance with the Intercreditor Agreement, instruct the Collateral Agent to take enforcement action against the Collateral. By virtue of the instructions given to the Collateral Agent described above, actions may be taken in respect of the Collateral that may be adverse to holders of the Notes. In such event, the only remedy available to holders of the Notes would be to sue for payment under the Notes and the Subsidiary Guarantees.

The Collateral Agent, acting in its capacity as such, shall have such duties with respect to the Collateral pledged, assigned or granted pursuant to the Security Documents as are set forth in the Intercreditor Agreement. Under certain circumstances, the Collateral Agent may have obligations under the Security Documents or the Intercreditor Agreement that are in conflict with the holders of the Notes. The Collateral Agent will not be under any obligation to exercise any rights or powers conferred under the Intercreditor Agreement or any of the Security Documents for the benefit of the holders of the Notes, the 2010 Notes, the 2012 Notes or the January 2013 Notes unless such holders have offered to the Collateral Agent indemnity and/or security satisfactory to the Collateral against any loss, liability or expense.

## USE OF PROCEEDS

We estimate that the net proceeds from this offering, after deducting the underwriting discounts and commissions and other estimated expenses payable in connection with this offering, will be approximately RMB977.7 million, which we plan to use to refinance certain of our existing indebtedness, finance our existing and new property development projects (including land premium and construction costs), and for other general corporate purposes.

We may adjust the foregoing plans in response to changing market conditions and, thus, reallocate the use of the proceeds. Pending application of the net proceeds of this offering, we intend to invest the net proceeds in Temporary Cash Investments (as defined under “Description of the Notes — Definitions”).

## EXCHANGE RATE INFORMATION

### China

The PBOC sets and publishes daily a base exchange rate with reference primarily to the supply and demand of Renminbi against a basket of currencies in the market during the prior day. PBOC also takes into account other factors, such as the general conditions existing in the international foreign exchange markets. From 1994 to July 20, 2005, the conversion of Renminbi into foreign currencies, including Hong Kong dollars and U.S. dollars, was based on rates set daily by PBOC on the basis of the previous day's inter-bank foreign exchange market rates and then current exchange rates in the world financial markets. During this period, the official exchange rate for the conversion of Renminbi to U.S. dollars remained generally stable. Although the PRC government introduced policies in 1996 to reduce restrictions on the convertibility of Renminbi into foreign currencies for current account items, conversion of Renminbi into foreign currencies for capital items, such as foreign direct investment, loan principals and securities trading, still requires the approval of SAFE and other relevant authorities. On July 21, 2005, the PRC government introduced a managed floating exchange rate system to allow the value of the Renminbi to fluctuate within a regulated band based on market supply and demand and by reference to a basket of currencies. On the same day, the value of the Renminbi appreciated by approximately 2% against the U.S. dollar. The PRC government has since made and in the future may make further adjustments to the exchange rate system.

On May 18, 2007, PBOC enlarged, the floating band for the trading prices in the inter-bank foreign exchange market of the Renminbi against the U.S. dollar from 0.3% to 0.5% around the central parity rate, effective on May 21, 2007. This allows the Renminbi to fluctuate against the U.S. dollar by up to 0.5% above or below the central parity rate published by PBOC. The floating band was further widened to 1.0% on April 16, 2012. The PBOC announces the closing price of a foreign currency traded against the Renminbi in the inter-bank foreign exchange market after the closing of the market on each working day, and makes it the central parity for trading against the Renminbi on the following working day.

The following table sets forth the noon buying rate for U.S. dollars in New York City for cable transfer in Renminbi as certified for customs purposes by the Federal Reserve Bank of New York for the periods indicated:

<u>Period</u>	<u>Noon buying rate</u>			
	<u>Period end</u>	<u>Average <sup>(1)</sup></u>	<u>High</u>	<u>Low</u>
		<b>(RMB per US\$1.00)</b>		
2008 . . . . .	6.8225	6.9193	7.2946	6.7800
2009 . . . . .	6.8259	6.8295	6.8470	6.8176
2010 . . . . .	6.6000	6.7603	6.8330	6.6000
2011 . . . . .	6.2939	6.4475	6.6364	6.2939
2012 . . . . .	6.2303	6.3085	6.3879	6.2221
November . . . . .	6.2265	6.2338	6.2454	6.2221
December . . . . .	6.2301	6.2328	6.2502	6.2251
2013				
January . . . . .	6.2186	6.2215	6.2303	6.2134
February . . . . .	6.2213	6.2323	6.2438	6.2213
March . . . . .	6.2108	6.2154	6.2246	6.2105
April . . . . .	6.1647	6.1861	6.2078	6.1647
May (through May 10) . . . . .	6.1415	6.1512	6.1665	6.1306

(1) Determined by averaging the rates on the last business day of each month during the relevant year, except for monthly average rates, which are determined by averaging the daily rates during the respective months.

### Hong Kong

The Hong Kong dollar is freely convertible into other currencies, including the U.S. dollar. Since October 17, 1983, the Hong Kong dollar has been linked to the U.S. dollar at the rate of HK\$7.80 to

US\$1.00. The Basic Law of the Hong Kong Special Administrative Region of the People's Republic of China (the "Basic Law"), which came into effect on July 1, 1997, provides that no foreign exchange control policies shall be applied in Hong Kong.

The market exchange rate of the Hong Kong dollar against the U.S. dollar continues to be determined by the forces of supply and demand in the foreign exchange market. However, against the background of the fixed rate system which applies to the issuance and withdrawal of Hong Kong currency in circulation, the market exchange rate has not deviated significantly from the level of HK\$7.80 to US\$1.00. In May 2005, the Hong Kong Monetary Authority broadened the 22-year-old trading band from the original rate of HK\$7.80 per U.S. dollar to a rate range of HK\$7.75 to HK\$7.85 per U.S. dollar. The Hong Kong government has indicated its intention to maintain the link within that rate range. Under the Basic Law, the Hong Kong dollar will continue to circulate and remain freely convertible. The Hong Kong government has also stated that it has no intention of imposing exchange controls in Hong Kong and that the Hong Kong dollar will remain freely convertible into other currencies, including the U.S. dollar. However, no assurance can be given that the Hong Kong government will maintain the link within the current rate range or at all.

The following table sets forth the noon buying rate for U.S. dollars in New York City for cable transfer in Hong Kong dollars as certified for customs purposes by the Federal Reserve Bank of New York for the periods indicated:

<u>Period</u>	<u>Noon buying rate</u>			
	<u>Period end</u>	<u>Average<sup>(1)</sup></u>	<u>High</u>	<u>Low</u>
		<b>(HK\$ per US\$1.00)</b>		
2008 .....	7.7449	7.7814	7.8159	7.7497
2009 .....	7.7536	7.7513	7.7618	7.7495
2010 .....	7.7810	7.7692	7.8040	7.7501
2011 .....	7.7663	7.7793	7.8087	7.7634
2012 .....	7.7507	7.7569	7.7699	7.7439
November .....	7.7501	7.7505	7.7518	7.7493
December .....	7.7507	7.7501	7.7518	7.7493
2013				
January .....	7.7560	7.7530	7.7585	7.7503
February .....	7.7546	7.7552	7.7580	7.7531
March .....	7.7629	7.7592	7.7640	7.7551
April .....	7.7606	7.7631	7.7652	7.7606
May (through May 10) .....	7.7606	7.7597	7.7606	7.7587

(1) Determined by averaging the rates on the last business day of each month during the relevant year, except for monthly average rates, which are determined by averaging the daily rates during the respective months.

## CAPITALIZATION AND INDEBTEDNESS

The following table sets forth our consolidated cash and cash equivalents, short-term debt and capitalization as of December 31, 2012 on an actual basis and on an adjusted basis after giving effect to the issuance of the Notes in this offering after deducting the underwriting discounts and commissions and other estimated expenses of this offering payable by us. The following table should be read in conjunction with the selected consolidated financial information and the audited consolidated financial statements and related notes included in this offering memorandum.

	As of December 31, 2012			
	Actual		As adjusted	
	RMB	US\$	RMB	US\$
		(unaudited)	(unaudited)	(unaudited)
	(in thousands)			
<b>Cash and cash equivalents<sup>(1)</sup></b> . . . . .	2,788,106	447,522	3,765,806	604,454
<b>Short-term borrowings</b>				
Borrowings – due within one year . . . . .	2,452,294	393,620	2,452,294	393,620
Amount due to related parties . . . . .	1,573	252	1,573	252
<b>Long-term borrowings<sup>(2)</sup></b>				
Borrowings – due after				
one year . . . . .	3,100,113	497,602	3,100,113	497,602
Senior Notes <sup>(3)</sup> . . . . .	2,329,003	373,831	2,329,003	373,831
Notes to be issued . . . . .	–	–	977,700	156,932
<b>Total long-term borrowings</b> . . . . .	5,429,116	871,433	6,406,816	1,028,365
<b>Total equity</b> . . . . .	6,921,166	1,110,924	6,921,166	1,110,924
<b>Total capitalization<sup>(4)</sup></b> . . . . .	12,350,282	1,982,357	13,327,982	2,139,289

*Notes:*

- <sup>(1)</sup> Cash and cash equivalents exclude restricted bank deposits of RMB707.6 million.
- <sup>(2)</sup> Subsequent to December 31, 2012, we issued the January 2013 Notes in the aggregate principal amount of US\$250 million on January 22, 2013. We have also, since December 31, 2012, in the ordinary course of business, entered into additional financing arrangements to finance our property developments and for general corporate purposes.
- <sup>(3)</sup> Senior Notes refer to the 2010 Notes and the 2012 Notes.
- <sup>(4)</sup> Total capitalization includes total long-term borrowings plus total equity.

Except as otherwise disclosed in this offering memorandum, there has been no material adverse change in our capitalization since December 31, 2012.

## SELECTED CONSOLIDATED FINANCIAL AND OTHER DATA

The following table presents our selected financial and other data. The selected consolidated statement of comprehensive income data for 2010, 2011 and 2012 and the selected consolidated statement of financial position data as of December 31, 2010, 2011 and 2012 set forth below (except for EBITDA data) have been derived from our consolidated financial statements for such years and as of such dates, as audited by Deloitte Touche Tohmatsu (“Deloitte”), the independent certified public accountants, and included elsewhere in this offering memorandum. Our financial statements have been prepared and presented in accordance with HKFRS, which differ in certain respects from generally accepted accounting principles in other jurisdictions. Certain financial data as of and for the year ended December 31, 2011 set forth in the following table have been restated for comparison purposes as a result of our adoption of certain amendments to Hong Kong Accounting Standard 12 “Deferred Tax: Recovery of Underlying Assets” (“HKAS 12”) which became effective on January 1, 2012. Summary financial data as of and for the year ended December 31, 2010 set forth in the following table have not been restated and therefore, may not be comparable to those as of and for the years ended December 31, 2011 and 2012. See Note 2 to consolidated financial statements as of and for the year ended December 31, 2012 included elsewhere in this offering memorandum. The selected financial data below should be read in conjunction with the section entitled “Management’s Discussion and Analysis of Financial Condition and Results of Operations” and our consolidated financial statements and the notes to those statements included elsewhere in this offering memorandum.

### Selected Consolidated Statement of Comprehensive Income and Other Financial Data

	For the year ended December 31,			
	2010 (RMB)	2011 (RMB)	2012 (RMB)	2012 (US\$)
				(unaudited)
				(in thousands)
<b>Revenue</b> . . . . .	4,471,234	5,592,350	6,230,050	999,992
Cost of sales and services . . . . .	(2,546,440)	(3,200,650)	(3,709,778)	(595,460)
<b>Gross profit</b> . . . . .	1,924,794	2,391,700	2,520,272	404,532
Other income, gains and losses . . . . .	32,199	46,922	31,800	5,104
Change in fair value of investment properties . . . . .	320,461	182,980	167,876	26,946
Recognition of change in fair value of completed properties for sale upon transfer to investment properties . . . . .	67,326	191,142	330,257	53,010
Selling and distribution expenses . . . . .	(131,278)	(262,433)	(314,100)	(50,417)
Administrative expenses . . . . .	(238,724)	(309,972)	(291,966)	(46,864)
Finance costs . . . . .	(180,131)	(108,471)	(57,698)	(9,261)
Impairment loss recognized in respect of goodwill . . . . .	(5,375)	(1,321)	–	–
Share of results of associates . . . . .	406	171	417	67
Gain on disposal of an associate . . . . .	–	3,533	–	–
Gain on disposal of a subsidiary . . . . .	–	17,589	–	–
<b>Profit before taxation</b> . . . . .	1,789,678	2,151,840	2,386,858	383,117
Income tax expense . . . . .	(828,708)	(1,038,344) <sup>(1)</sup>	(1,261,209)	(202,438)
<b>Profit for the year</b> . . . . .	960,970	1,113,496 <sup>(1)</sup>	1,125,649	180,679

	For the year ended December 31,			
	2010 (RMB)	2011 (RMB)	2012 (RMB)	2012 (US\$) (unaudited)
	(in thousands)			
<b>Other comprehensive income (expense)</b>				
Surplus on revaluation of properties . . . . .	–	11,795	45,708	7,337
Deferred taxation liability arising from revaluation of properties . . . . .	–	(4,851) <sup>(1)</sup>	(14,633)	(2,349)
Other comprehensive income for the year/period (net of income tax) . . . . .	–	6,944 <sup>(1)</sup>	31,075	4,988
<b>Total comprehensive income for the year . . . . .</b>	<u>960,970</u>	<u>1,120,440<sup>(1)</sup></u>	<u>1,156,724</u>	<u>185,667</u>
Profit for the year attributable to:				
Owners of the Company . . . . .	807,281	1,057,479 <sup>(1)</sup>	1,139,241	182,861
Non-controlling interests . . . . .	153,689	56,017	(13,592)	(2,182)
	<u>960,970</u>	<u>1,113,496<sup>(1)</sup></u>	<u>1,125,649</u>	<u>180,679</u>
Total comprehensive income attributable to:				
Owners of the Company . . . . .	807,281	1,064,423 <sup>(1)</sup>	1,163,210	186,708
Non-controlling interests . . . . .	153,689	56,017	(6,486)	(1,041)
	<u>960,970</u>	<u>1,120,440<sup>(1)</sup></u>	<u>1,156,724</u>	<u>185,667</u>
Earnings per share – Basic (RMB) . . . . .	0.17	0.21 <sup>(1)</sup>	0.22	0.04
<b>Other Financial Data</b>				
EBITDA <sup>(2)</sup> . . . . .	1,591,117	1,911,194	1,996,712	320,494
EBITDA margin <sup>(3)</sup> . . . . .	36%	34%	32%	32%

Notes:

(1) The Group has applied certain amendments to HKAS 12 that are mandatorily effective for the results for the year ended December 31, 2012. Under the amendments to HKAS 12, investment properties that are measured using the fair value model in accordance with Hong Kong Accounting Standard 40 “Investment Property” (“HKAS 40”) are presumed to be recovered through sale for the purposes of measuring deferred taxes, unless the presumption is rebutted in certain circumstances.

The Group measures its investment properties using the fair value model. As a result of the application of the amendments to HKAS 12, the directors reviewed the Group’s investment property portfolios and concluded that the Group’s investment properties are not held under a business model whose objective is to consume substantially all of the economic benefits embodied in the investment properties over time. Accordingly the presumption set out in the amendments to HKAS 12 is not rebutted.

As a result of the application of the amendments to HKAS 12, the Group recognized the deferred taxes on changes in fair value of the Group’s investment properties in PRC taking into account the land appreciation tax and enterprise income tax payable upon sales of those investment properties. Previously, the Group recognized deferred taxes on changes in fair value of investment properties on the basis that the entire carrying amounts of the properties were recovered through use.



The effect of the change in accounting policy described above on the results for the current and preceding year by line items presented in the consolidated statement of comprehensive income is as follows:

	For the year ended December 31,	
	2011	2012
	(RMB)	(RMB)
	(in thousands)	
Increase in income tax expense and decrease in profit for the year . . . . .	96,145	131,709
Increase in deferred tax charge recognised in other comprehensive income in relation to change in fair value of owner-occupied properties to investment properties . . . . .	1,902	3,205
	<u>98,047</u>	<u>134,914</u>
	For the year ended December 31,	
	2011	2012
	(RMB)	(RMB)
	(in thousands)	
<b>Impact on basic earnings per share</b>		
Basic earnings per share before adjustment . . . . .	0.23	0.24
Adjustments arising from change in accounting policy in relation to application of amendments to HKAS 12 in respect of deferred taxes on investment properties . . . . .	(0.02)	(0.02)
Reported basic earnings per share . . . . .	<u>0.21</u>	<u>0.22</u>

- (2) *EBITDA for any period consists of profit from operating activities before change in fair value of investment properties and impairment loss recognized in respect of goodwill plus depreciation and amortization expenses. EBITDA is not a standard measure under HKFRS. EBITDA is a widely used financial indicator of a company's ability to service and incur debt. EBITDA should not be considered in isolation or construed as an alternative to cash flows, net income or any other measure of financial performance or as an indicator of our operating performance, liquidity, profitability or cash flows generated by operating, investing or financing activities. EBITDA does not account for taxes, interest expense or other non-operating cash expenses. In evaluating EBITDA, we believe that investors should consider, among other things, the components of EBITDA such as sales and operating expenses and the amount by which EBITDA exceeds capital expenditures and other charges. We have included EBITDA because we believe it is a useful supplement to cash flow data as a measure of our performance and our ability to generate cash flow from operations to cover debt service and taxes. EBITDA presented herein may not be comparable to similarly titled measures presented by other companies. Investors should not compare our EBITDA to EBITDA presented by other companies because not all companies use the same definition. See the section entitled "Management's Discussion and Analysis of Financial Condition and Results of Operations — Non-GAAP Financial Measures" for a reconciliation of our profit for the year under HKFRS to our definition of EBITDA. Investors should also note that EBITDA as presented herein may be calculated differently from Consolidated EBITDA as defined and used in the Indenture governing the Notes. Interest expense excludes amounts capitalized. See the section entitled "Description of the Notes — Definitions" for a description of the manner in which Consolidated EBITDA is defined for purposes of the Indenture governing the Notes.*
- (3) *EBITDA margin is calculated by dividing EBITDA by revenue.*

## Selected Consolidated Statement of Financial Position

	As of December 31,			
	2010 (RMB)	2011 (RMB)	2012 (RMB)	2012 (US\$)
	(unaudited)			
	(in thousands)			
<b>Non-current Assets</b>				
Property, plant and equipment . . . . .	374,434	529,215	585,687	94,009
Investment properties . . . . .	1,697,677	2,443,694	3,422,233	549,306
Interests in associates . . . . .	17,795	1,077	1,171	188
Interest in a jointly controlled entity . . . . .	–	–	19,720	3,165
Advance to an associate . . . . .	72,041	–	–	–
Goodwill . . . . .	–	–	16,488	2,647
Prepaid lease payments . . . . .	346,045	163,307	822,252	131,981
Premium on prepaid lease payments . . . . .	359,203	440,275	591,144	94,885
Prepayment . . . . .	43,370	11,890	–	–
Land development expenditure . . . . .	393,849	1,335,848	1,217,463	195,416
Deposits paid for acquisition of subsidiaries . .	–	8,084	6,890	1,106
Deposits paid for acquisition of a property project . . . . .	37,000	104,900	126,004	20,225
Deposit paid for acquisition of land use rights .	–	–	158,123	25,380
Deferred tax assets . . . . .	157,504	220,826	329,372	52,868
	<u>3,498,918</u>	<u>5,259,116</u>	<u>7,296,547</u>	<u>1,171,176</u>
<b>Current Assets</b>				
Properties for sale . . . . .	7,644,582	10,222,320	11,372,628	1,825,433
Prepaid lease payments . . . . .	6,881	6,413	28,121	4,514
Premium on prepaid lease payments . . . . .	6,101	11,157	19,219	3,085
Deposits paid for acquisition of land use rights . . . . .	763,095	–	–	–
Trade and other receivables . . . . .	977,179	1,216,377	2,142,501	343,895
Amounts due from related parties . . . . .	7,500	3,262	–	–
Amounts due from customers for contract works . . . . .	15,939	16,359	52,482	8,424
Tax recoverable . . . . .	5,580	51,143	77,179	12,388
Financial assets at fair value through profit or loss . . . . .	–	–	42,200	6,774
Restricted bank deposits . . . . .	85,161	315,134	707,614	113,580
Bank balances and cash . . . . .	2,371,452	1,021,355	2,788,106	447,521
	<u>11,883,470</u>	<u>12,863,520</u>	<u>17,230,050</u>	<u>2,765,614</u>
<b>Current Liabilities</b>				
Trade and other payables . . . . .	1,686,718	2,268,829	2,603,457	417,884
Deposits received for sale of properties . . . . .	1,834,067	2,619,004	4,186,104	671,916
Amounts due to customers for contract works .	–	–	2,291	368
Amounts due to related parties . . . . .	100,549	2,547	1,573	252
Tax payable . . . . .	1,104,147	1,527,259	2,238,038	359,230
Borrowings – due within one year . . . . .	2,132,381	2,100,069	2,452,294	393,620
	<u>6,857,862</u>	<u>8,517,708</u>	<u>11,483,757</u>	<u>1,843,270</u>
<b>Net Current Assets</b> . . . . .	<u>5,025,608</u>	<u>4,345,812</u>	<u>5,746,293</u>	<u>922,344</u>
<b>Total Assets less Current Liabilities</b> . . . . .	<u>8,524,526</u>	<u>9,604,928</u>	<u>13,042,840</u>	<u>2,093,520</u>

	As of December 31,			
	2010 (RMB)	2011 (RMB)	2012 (RMB)	2012 (US\$) (unaudited)
	(in thousands)			
<b>Non-Current Liabilities</b>				
Deferred tax liabilities . . . . .	128,121	429,372 <sup>(1)</sup>	692,558	111,163
Amount due to a related party . . . . .	–	–	–	–
Borrowings – due after one year . . . . .	2,642,605	2,640,933	3,100,113	497,602
Senior notes . . . . .	787,330	752,367	2,329,003	373,831
	<u>3,558,056</u>	<u>3,822,672<sup>(1)</sup></u>	<u>6,121,674</u>	<u>982,596</u>
	<u>4,966,470</u>	<u>5,782,256<sup>(1)</sup></u>	<u>6,921,166</u>	<u>1,110,924</u>
<b>Capital and Reserves</b>				
Share capital . . . . .	429,389	457,093	457,093	73,369
Reserves . . . . .	<u>4,072,745</u>	<u>5,144,506<sup>(1)</sup></u>	<u>6,144,037</u>	<u>986,186</u>
Equity attributable to owners of the Company . . . . .	4,502,134	5,601,599 <sup>(1)</sup>	6,601,130	1,059,555
Non-controlling interests . . . . .	<u>464,336</u>	<u>180,657</u>	<u>320,036</u>	<u>51,369</u>
	<u>4,966,470</u>	<u>5,782,256<sup>(1)</sup></u>	<u>6,921,166</u>	<u>1,110,924</u>

Note:

(1) The Group has applied certain amendments to HKAS 12 that are mandatorily effective for the results for the year ended December 31, 2012. Under the amendments to HKAS 12, investment properties that are measured using the fair value model in accordance with HKAS 40 are presumed to be recovered through sale for the purposes of measuring deferred taxes, unless the presumption is rebutted in certain circumstances.

The Group measures its investment properties using the fair value model. As a result of the application of the amendments to HKAS 12, the directors reviewed the Group's investment property portfolios and concluded that the Group's investment properties are not held under a business model whose objective is to consume substantially all of the economic benefits embodied in the investment properties over time. Accordingly the presumption set out in the amendments to HKAS 12 is not rebutted.

As a result of the application of the amendments to HKAS 12, the Group recognized the deferred taxes on changes in fair value of the Group's investment properties in PRC taking into account the land appreciation tax and enterprise income tax payable upon sales of those investment properties. Previously, the Group recognized deferred taxes on changes in fair value of investment properties on the basis that the entire carrying amounts of the properties were recovered through use.

The effect of the change in accounting policy described above on the financial positions of the Group as of December 31, 2011, is as follow:

	As of December 31, 2011	Adjustments	As of December 31, 2011
	(originally stated)		(restated)
	(RMB)	(RMB)	(RMB)
	(in thousands)		
Deferred tax liabilities and total effect of net assets . . . . .	<u>212,347</u>	<u>217,025</u>	<u>429,372</u>
Accumulated profits . . . . .	2,663,549	(166,628)	2,496,921
Special reserve . . . . .	(15,673)	(48,495)	(64,168)
Property revaluation reserve . . . . .	8,846	(1,902)	6,944
Total effect on equity . . . . .	<u>2,656,722</u>	<u>(217,025)</u>	<u>2,439,697</u>

The effect of the change in accounting policy described above on the financial positions of the Group as of January 1, 2011, is as follows:

	<u>As of January 1, 2011</u>		<u>As of January 1, 2011</u>
	<u>(originally stated)</u>	<u>Adjustments</u>	<u>(restated)</u>
	<u>(RMB)</u>	<u>(RMB)</u>	<u>(RMB)</u>
		(in thousands)	
Deferred tax liabilities and total effect on net assets . . . . .	128,121	118,978	247,099
Accumulated profits . . . . .	1,516,228	(70,483)	1,445,745
Non-controlling interests . . . . .	464,336	(48,495)	415,841
Total effect on equity. . . . .	<u>1,980,564</u>	<u>(118,978)</u>	<u>1,861,586</u>

## MANAGEMENT'S DISCUSSION AND ANALYSIS OF FINANCIAL CONDITION AND RESULTS OF OPERATIONS

*The following discussion should be read in conjunction with the section entitled "Selected Consolidated Financial and Other Data" and our consolidated financial statements, including the notes thereto, included elsewhere in this offering memorandum. All significant intra-group transactions, balances and unrealized gains on intra-group transactions have been eliminated.*

*Our consolidated financial statements were prepared in accordance with HKFRS, which differ in certain material respects from generally accepted accounting principles in other jurisdictions. In this section of the offering memorandum, references to "2010", "2011" and "2012" refer to our financial years ended December 31, 2010, 2011 and 2012, respectively.*

### Overview

We are a leading property developer and property related service provider in China. Our target customers are affluent middle- to upper-class individuals and families and small- to medium-sized enterprises. Our regions of focus are currently the Chengdu-Chongqing Economic Zone, the Pearl River Delta region, the Yangtze River Delta region and the Beijing-Tianjin metropolitan region.

As of December 31, 2012, we had a total of 40 projects at various stages of development (including completed projects, projects under development and projects held for future development), including 14 projects located in the Chengdu-Chongqing Economic Zone, 13 projects located in the Pearl River Delta region, eight projects located in the Yangtze River Delta region and five projects located in the Beijing-Tianjin metropolitan region.

As of December 31, 2012, we had a total land bank of approximately 11,714,530 square meters, which consists of:

- an aggregate planned GFA of approximately 8,025,896 square meters of properties for which we had fully paid the land premium and obtained land use rights (consisting of an aggregate planned GFA of approximately 2,672,213 square meters of properties under development and an aggregate planned GFA of approximately 5,353,683 square meters of properties held for future development for which we have obtained land use rights); and
- an aggregate planned GFA of approximately 3,688,634 square meters of properties for which we had entered into preliminary framework agreements but had not obtained the land use rights or property rights.

Of our total land bank as of December 31, 2012, approximately 6,645,173 square meters, or 56.7%, were located in the Chengdu-Chongqing Economic Zone; approximately 3,317,137 square meters, or 28.3%, were located in the Pearl River Delta region; approximately 901,562 square meters, or 7.7%, were located in the Yangtze River Delta region; and approximately 850,658 square meters, or 7.3%, were located in the Beijing-Tianjin metropolitan region. We develop most of our properties, including properties that are currently under development, for sale but will hold certain of these developed properties for investment and hotel management purposes.

In addition to property development, we provide property operation services to properties that are developed by us as well as those developed by others.

For the years ended December 31, 2010, 2011 and 2012, our revenue was RMB4,471.2 million, RMB5,592.4 million and RMB6,230.1 million (US\$1,000.0 million), respectively. For the same periods, our profit for the year was RMB961.0 million, RMB1,113.5 million and RMB1,125.6 million (US\$180.7 million), respectively.

### Key Factors Affecting Our Results of Operations

Our business, results of operations and financial condition have been, and we expect will continue to be, affected by a number of factors and risks, many of which are beyond our control. Please refer to the section entitled "Risk Factors" in this offering memorandum. The key factors and material risks include the following:

## *Economic Conditions and Regulatory Environment in the PRC*

Our results of operations are subject to political, economic, fiscal, legal and social developments in the PRC in general and in cities and regions in which we operate, such as in the Chengdu-Chongqing Economic Zone, the Pearl River Delta region, the Yangtze River Delta region and the Beijing-Tianjin metropolitan region, as well as economic, fiscal, legal and social developments specifically affecting the real estate sector in the PRC and in cities and regions in which we operate, including:

- continued growth in the economy, population and rate of urbanization in the PRC and in cities and regions in which we operate as such factors drive the demand for purchase or rental of real estate properties;
- the regulatory and fiscal environment of the PRC, specifically, the regulatory and fiscal environment affecting the property development industry, including tax policies, land grant and land use rights policies, pre-sale policies, policies on bank financing and interest rates and the availability of mortgage financing and other macro-economic policies; and
- the performance of the PRC's property market, in particular, the supply and demand for real estate properties and pricing trends in the medium- to high-end property sector in the cities and regions in which we operate.

The slowdown of the worldwide economy from 2008 to early 2009, including that of China, resulted in the decline in real estate market sentiment, which have adversely affected property demand and average selling prices and rental prices in many areas of China. Since then PRC and many other foreign economies have shown signs of recovery. In 2010, a financial crisis emerged in Europe, triggered by high budget deficits and rising direct and contingent sovereign debt in Greece, Ireland, Italy, Portugal and Spain, which created concerns about the ability of these European nations to continue to service their sovereign debt obligations. On August 6, 2011, S&P downgraded the rating for long-term United States debt to "AA+" from "AAA" for the first time in 70 years. The downgrade of United States debt by S&P, coupled with the economic turmoil in Europe and other parts of the world could lead to another global economic downturn and financial market crisis. The outlook for the world economy and financial markets remains uncertain. In Europe, it is unclear whether the European sovereign debt crisis will be contained and what effects it may have. In the United States, the unemployment rate remains high, and recovery in the housing market remains subdued. In Asia and other emerging markets, some countries are expecting increasing inflationary pressure as a consequence of liberal monetary policy or excessive foreign fund inflow, or both. In the Middle East, political unrest in various countries has resulted in economic instability and uncertainty. China's economic growth may slow down due to weakened exports. There is also considerable uncertainty over the long-term effects of the expansionary monetary and fiscal policies that have been adopted by the central banks and financial authorities of some of the world's leading economies, including China. It is difficult to determine the impact of any global economic slowdown and financial crisis on the property industry in China. If the global economic slowdown and financial market crisis continue or become more severe than currently estimated, our business prospects, revenues, cash flows and financial condition could be materially and adversely affected. See "Risk Factors – Risks Relating to Our Business – We may be adversely affected by fluctuations in the global economy and financial markets."

Our business and results of operations have also been, and will continue to be, affected by the regulatory environment in China, PRC governmental policies and measures taken by the PRC government on property development and related industries. In recent years, the PRC government has implemented a series of measures with a view to controlling the growth of the economy, including the property markets. While the property industry is regarded as a pillar industry by the PRC government, the PRC government has taken various restrictive measures to discourage speculation in the property market and to increase the supply of affordable residential properties. From time to time, the PRC government adjusts or introduces macroeconomic control policies to encourage or restrict development in the private property sector through regulating, among others, land grants, pre-sales of properties, bank financing and taxation. Measures taken by the PRC government to control money supply, credit availability and fixed assets also have a direct impact on our business and results of operations. The PRC government may introduce initiatives which may affect our access to capital and the means in which we may finance our property development. See "Regulation."

Changes in the economic conditions and the regulatory environment in the PRC in general or in cities and regions in which we operate may affect the selling price of our properties as well as the time it will take us to pre-sell or sell the properties we have developed. Lower selling prices, without a corresponding decrease in costs, will adversely affect our gross profit and reduce cash flow generated from the sale of our properties, which may increase our reliance on external financing and negatively impact our ability to finance the continuing growth of our business. A prolonged selling period will increase our selling and distribution costs as well as reduce the cash flow generated from the sale of our properties for a particular period. On the other hand, higher selling price and a shorter selling period may increase our gross profit, reduce our selling and distribution costs and increase our cash flow for a particular period to enable us to fund the continuing growth of our business.

### ***Costs of Labor, Construction Materials and Building Equipment***

Our results of operations are affected by the costs of labor, construction materials such as steel and cement, and building equipment. As a result of the economic growth and the boom in the property development industry in the PRC, wages for construction workers and the prices of construction materials and building equipment have experienced substantial increase in recent years. Further, the PRC Labor Contract Law (中華人民共和國勞動合同法) that came into effect on January 1, 2008, enhanced the protection for employees and increased employers' liability in many circumstances which may further increase our labor cost. To the extent that we are not able to pass such increased costs on to our customers, our gross margin and our results of operations would be adversely affected.

To reduce our exposure to price volatility of construction materials, we typically enter into contracts with third party construction contractors pursuant to which the construction contractors are responsible for procuring most of the construction materials for our property development projects. Such construction contracts are typically fixed or capped unit price contracts where the unit price of the construction materials is fixed or capped and the total price payable depends on our quantity requirement. Similarly, under the terms of most of our construction contracts, labor wages are paid by the construction contractors and increasing costs of labor are born by the contractors during the term of such contracts. However, we are exposed to price volatility of labor and construction materials to the extent that we periodically enter into new or renew our construction contracts at different terms during the life of a project, which may span over several years, or if we hire construction workers directly or procure the construction materials directly from suppliers, any of which may result in increased cost of sales and decreased profit margin. Furthermore, we typically pre-sell our properties prior to their completion and we will not be able to pass the increased costs on to our customers if construction costs increase subsequent to the time of such pre-sale. In addition, as we typically procure building equipment, such as elevators, interior decoration materials and air conditioning systems, directly from suppliers, we are directly exposed to the price volatility of building equipment.

### ***Availability and Cost of Land***

To have a steady stream of properties available for sale and to achieve continuous growth in the long term, we need to replenish and increase land reserves suitable for the development of our projects at commercially acceptable prices. Land acquisition costs are one of the primary components of our cost of sales for property development, which is consisted of land premium and where necessary, the cost of demolition of existing buildings and relocation of residents. We expect competition among property developers for land reserves that are suitable for property development to remain intense. In addition, PRC governmental land supply policies and implementation measures may further intensify competition for land in China among property developers. For example, although privately held land use rights are not prevented from being traded in the secondary market, the statutory means of public tender, auction and listing-for-sale practice in respect of the grant of state-owned land use rights is likely to increase competition for available land and to increase land acquisition costs. Furthermore, in November 2009, the PRC government raised the minimum down-payment of land premium to 50% and now requires the land premium to be fully paid within one year after the signing of a land grant contract, subject to limited exceptions. Such change of policy may materially and adversely affect our cash flow and our ability to acquire suitable land for our operations.

## *LAT*

We are subject to LAT with respect to the appreciated value of land. LAT applies to both domestic and foreign developers and investors in real properties in China, irrespective of whether they are corporate entities or individuals. We incurred LAT expenses of RMB440.8 million, RMB403.7 million and RMB580.1 million (US\$93.1 million) in 2010, 2011 and 2012, respectively. We believe we have accrued all LAT payable on our property sales and transfers in accordance with the progressive rates specified in relevant PRC tax laws, less amounts previously paid under the levy method applied by relevant PRC local tax authorities. However, the provision for LAT requires our management to use a significant amount of judgment and estimates with respect to, among other things, the anticipated proceeds to be derived from the sale of the entire phase of the project or the entire project, the amount of land appreciation and the various deductible items. The relevant PRC local tax authorities may not agree with our estimates or the basis on which we calculate our LAT liabilities. If the LAT provisions we have made are substantially lower than the actual LAT amounts assessed by the relevant PRC local tax authorities in the future, our results of operations and cash flows will be materially and adversely affected. See “Regulation — I. Legal Supervision Relating to the Property Sector in the PRC — J. Major Taxes Applicable to Property Development Enterprises — (iii) Land Appreciation Tax.”

## *Access to and Cost of Financing*

Borrowing is an important source of funding for our property developments. As of December 31, 2010, 2011 and 2012, our outstanding borrowings (excluding the 2010 Notes, the 2012 Notes and amounts due to related parties) amounted to RMB4,775.0 million, RMB4,741.0 million and RMB5,552.4 million (US\$891.2 million), respectively. As commercial banks in China link the interest rates on their borrowings to the benchmark lending rates published by the PBOC, any increase in such benchmark lending rates will increase the interest costs for financing our developments. Our access to capital and cost of financing are affected by restrictions imposed from time to time by the PRC government on bank lending for property development. A significant portion of our finance costs are capitalized rather than being expensed at the time they are incurred to the extent such costs are directly attributable to the acquisition and construction of a project or a projected phase. The following table sets forth the capitalized finance costs under each eligible assets for capitalization for the periods indicated:

	For the year ended December 31,			
	2010	2011	2012	2012
	(RMB)	(RMB)	(RMB)	(US\$)
	(unaudited)			
	(in thousands)			
Properties under development				
for sale . . . . .	(139,657)	(256,522)	(381,978)	(61,312)
Land development expenditure . . . . .	–	(32,039)	(120,570)	(19,353)
Investment properties under development . . . . .	–	(4,663)	(4,951)	(795)
Construction in progress . . . . .	(3,216)	(256)	(7,835)	(1,258)

An increase in our finance costs would negatively affect our profitability and results of operations and the availability of financing will affect our ability to engage in our project development activities, which will negatively affect our results of operations.

## *Timing of Property Development*

The number of property developments that a developer can undertake during any particular period is limited due to substantial capital requirements for land acquisitions and construction costs as well as limited land supply. In addition, significant time is required for property developments and it may take many months or possibly years before pre-sales of certain property developments occur. Moreover, while the pre-sale of a property generates positive cash flow for us in the period in which it is made, we must place a portion of such proceeds in restricted bank accounts and may only use such cash for specified purposes, and no sales revenue is recognized in respect of such property until the relevant property is delivered to the purchaser. In addition, as market demand is not stable, sales revenue an particular period



can also depend on our ability to gauge the expected demand in the market at the expected launch time for completion of a particular project. As a result, our results of operations have fluctuated in the past and are likely to continue to fluctuate in the future.

### ***Changes in Product Mix***

The prices and gross profit margins of our products vary by the type of properties we develop and sell. Our gross profit margin is affected by the proportion of sales revenue attributable to our high gross margin products compared to sales revenue attributable to lower gross margin products. Commercial properties and office spaces in general command higher selling prices than residential properties, and the proportion of commercial/office and residential properties sold may affect our revenue and profitability during the relevant period. In 2010, 2011 and 2012, the gross margin for our commercial/office properties was 51.2%, 50.9% and 54.3%, respectively, and the gross margin for our residential properties was 38.2%, 40.2% and 33.1%, respectively. In addition, properties in larger scale projects will typically command a higher selling price as the overall development approaches completion due to the attractiveness of a more established development, thereby increasing our gross margin during the relevant period. Our product mix varies from period to period due to a number of reasons, including government-regulated plot ratios, project locations, land size and cost, market conditions and our development planning. We adjust our product mix from time to time, and time our project launches according to our development plans.

### ***Change in Fair Value of our Investment Properties***

Under HKFRS, we are required to reassess the fair value of our completed investment properties as of the date of the consolidated statement of financial position, and gains or losses arising from changes in the fair value of our investment properties are included in our consolidated statement of comprehensive income in the period in which they arise. As of December 31, 2010, 2011 and 2012, the fair value of our investment properties, which include investment properties that are under development, were RMB1,697.7 million, RMB2,443.7 million and RMB3,422.2 million (US\$549.3 million), respectively. In 2010, 2011 and 2012, we experienced a gain on fair value changes of investment properties of RMB320.5 million, RMB183.0 million and RMB167.9 million (US\$26.9 million), respectively. The fair value of each of our investment properties is likely to continue to fluctuate from time to time in the future, and volatility of our results of operations may increase as a result of fair value gains or losses. Any decrease in the fair value of our investment properties would adversely affect our profitability. In addition, fair value gains or losses do not give rise to any change to our cash position unless the relevant investment property is sold. Therefore, we may experience constraints on our liquidity even though our profitability increases.

### ***Pre-sales***

Proceeds from pre-sales of properties under development constitute the most important source of our operating cash inflow during our project development process. PRC law allows us to pre-sell properties before their completion upon satisfaction of certain conditions and requires us to use the pre-sale proceeds to develop the projects that are pre-sold. The amount and timing of cash received from pre-sales are affected by a number of factors, including timing and other restrictions on pre-sales imposed by the relevant PRC laws and regulations, market demand and the number for our properties that are available for pre-sale. A restriction on our ability to engage in the pre-sales of our properties could result in a reduced cash inflow, which would increase our reliance on external financing and increase our finance costs, which could have an adverse effect on our ability to finance our continuing property developments and our results of operations.

## Certain Income Statement Items

### Revenue

Our revenue comprises revenue derived from (i) sales of our developed properties, (ii) lease of investment properties, (iii) provision of property agency and related services, (iv) provision of property operation and related services, and (v) provision of hotel management and related services. The following table sets forth the revenue attributable to each of the components above:

	For the year ended December 31,						
	2010		2011		2012		
	(RMB)	(%)	(RMB)	(%)	(RMB)	(US\$)	(%)
	(unaudited)						
Property development . . . . .	4,320,413	96.6	5,396,289	96.5	5,885,314	944,658	94.5
Property investment . . . . .	17,727	0.4	37,887	0.7	90,266	14,489	1.4
Property agency services . . . . .	36,845	0.8	10,571	0.2	14,470	2,322	0.2
Property operation services . . . . .	89,228	2.0	124,895	2.2	184,683	29,644	3.0
Hotel services . . . . .	7,021	0.2	22,708	0.4	55,317	8,879	0.9
Total . . . . .	4,471,234	100	5,592,350	100	6,230,050	999,992	100.0

### Property Development

We recognize revenue from the sale of a property when the significant risks and rewards of ownership have been transferred to the purchaser, which is when the relevant property has been completed and the possession of the property has been delivered to the purchaser. Revenue from property development represents proceeds from sales of our properties held for sales. As we derive a majority of our revenue from property development, our results of operations for a given period depend upon the GFA of our properties available for sale during that period, the market demand for those properties and the selling prices of such properties. Conditions of the property markets in which we operate change from period to period and are affected by the economic, political and regulatory developments in the PRC in general as well as in the cities and regions in which we operate. See “— Key Factors Affecting Our Results of Operations.” The table below sets forth, for the periods so indicated, total revenue derived from each of our projects, the aggregate GFA of properties sold, the average selling prices per square meter for these properties, as measured by dividing total revenue by aggregate GFA sold:

	For the year ended December 31,								
	2010			2011			2012		
	Total Revenue	GFA Sold	Avg. Selling Price/Square Meter	Total Revenue	GFA Sold	Avg. Selling Price/Square Meter	Total Revenue	GFA Sold	Avg. Selling Price/Square Meter
	(in RMB thousands)	(square meters)	(in RMB)	(in RMB thousands)	(square meters)	(in RMB)	(in RMB thousands)	(square meters)	(in RMB)
Shenzhen Love Forever (深圳花郡) . . . . .	609,748	46,448	13,127	907,563	44,903	20,212	2,852	99	28,808
Shenzhen Meinian International Complex (深圳美年國際廣場) . . . . .	-	-	-	897,520	32,118	27,944	131,039	4,378	29,931
Chengdu MIC Plaza (formerly known as Chengdu Meinian International Plaza, 成都美年國際廣場) . . . . .	1,030,385	137,541	7,491	1,198,527	130,058	9,215	147,861	19,964	7,406
Chengdu Grande Valley (成都大溪谷) . . . . .	156,513	21,251	7,365	138,899	16,522	8,407	101,440	12,211	8,307
Chengdu Belle Epoque (成都君山) . . . . .	143,808	20,737	6,935	33,125	3,757	8,818	32,181	5,210	6,177
Dongguan Mont Conquerant (東莞君山) . . . . .	210,065	18,853	11,142	564,365	61,750	9,139	242,746	27,887	8,705
Yixing Town on the Water (宜興雲海間) . . . . .	254,039	21,117	12,030	14,374	1,293	11,121	-	-	-

For the year ended December 31,

	2010		2011			2012			
	Total Revenue	Avg. Selling Price/Square Meter	Total Revenue	Avg. Selling Price/Square Meter	Total Revenue	Avg. Selling Price/Square Meter	GFA Sold		
	(in RMB thousands)	(square meters) (in RMB)	(in RMB thousands)	(square meters) (in RMB)	(in RMB thousands)	(square meters) (in RMB)	(square meters)	(in RMB)	
Shenzhen Flower Harbor (深圳花港家園)	35,256	1,370	25,744	9,036	766	11,800	-	-	-
Chengdu Hailun Plaza (成都喜年廣場)	1,165,767	89,423	13,037	6,084	168	36,286	-	-	-
Tianjin Hailun Plaza (天津喜年廣場)	278,430	26,678	10,437	660,198	50,674	13,028	20,729	1,768	11,725
Huizhou Fantasia Special Town (惠州別樣城)	-	-	-	366,991	70,136	5,233	691,572	137,054	5,046
Shenzhen Funian Plaza (深圳福年廣場)	-	-	-	-	-	-	779,537	22,592	34,505
Suzhou Lago Paradise (蘇州太湖天城)	-	-	-	131,398	11,880	11,060	247,283	22,819	10,837
Chengdu Fantasia Town (成都花樣城)	-	-	-	378,592	88,059	4,299	584,605	138,738	4,214
Shenzhen Future Plaza (深圳香年廣場)	218,946	7,338	29,836	-	-	-	-	-	-
Chengdu Future Plaza (成都香年廣場)	-	-	-	-	-	-	1,311,210	125,194	10,473
Tianjin Future Plaza (天津香年廣場)	-	-	-	-	-	-	594,511	50,702	11,725
Dongguan Wonderland (東莞江山)	-	-	-	-	-	-	511,323	62,483	8,183
Wuxi Love Forever (無錫花都)	-	-	-	-	-	-	438,723	62,496	7,020
	4,102,957	390,756	10,500	5,306,672	512,084	10,363	5,837,612	693,595	8,416
Others (including sales of carparks and construction of relocation housing)	217,456	-	-	89,617	-	-	47,702	-	-
	4,320,413	-	-	5,396,289	-	-	5,885,314	-	-

Consistent with industry practice, we typically enter into purchase contracts with customers while the properties are still under development but after satisfying the conditions for pre-sales in accordance with PRC laws and regulations. See “Business — Property Development — Pre-sale, Sales and Marketing.” In general, there is a time difference, typically ranging from several months to one year, between the time we commence pre-selling properties under development and the completion of the construction of such properties. We do not recognize any revenue from the pre-sales of our properties until such properties are completed and the properties have been delivered to the purchasers, even though we receive payments at various stages prior to delivery. Before the delivery of a pre-sold property, payments received from purchasers are recorded as “Deposits received on sale of properties” under “Current Liabilities” on our consolidated statements of financial position.

### *Property Investment*

Revenue derived from our properties held for investment represents revenue received and receivable from our investment properties, which has historically been generated from the rental of offices, retail shops and car parking spaces, and recognized on a straight-line basis over the relevant lease period. Going forward, we expect that our revenue from investment properties will increase as we develop additional properties and as we expand the properties that are held for investment. We believe the increase of such revenue will help us reduce over-reliance on a particular sector of the property market, diversify our risk exposure and provide us with a stable recurring revenue.

### *Property Agency Services*

Prior to February 2011, we provided property agency services through one of our subsidiaries, Shenzhen Xingyan Property Consultancy Co., Ltd. (“Xingyan Property Consultancy”), which we disposed of in February 2011. See “Business — Our Property Agency Business.” Revenue derived from property agency services is recognized when services are provided. This means that for primary property agency services, revenue is recognized when a successful sale of a property has occurred, which is defined in each contract and is usually achieved after the purchaser has executed the purchase contract, made the required down payment, and the purchase contract has been registered with the relevant government authorities. Each agency contract specifies commission rates expressed as a percentage of the project transaction value, defined as the aggregate sales proceeds of all property units we have sold for the project. Typically, agency contracts stipulate that the developer clients are responsible for the cost of promotion and advertising, either by paying the costs directly or reimbursing us for the promotion and advertising costs we have incurred. Commissions are typically settled at the end of a sales period typically lasting several months. During the time between when sales are actually made and the time of collection, commissions are recorded as “trade and other receivables” on our consolidated statement of financial position. Additional revenue may also be earned if certain sales and other performance targets are achieved, and is recognized when the relevant required targets are accomplished. Services are considered provided and revenue is recognized for secondary property brokerage services upon execution of a transaction agreement between the buyer/lessee and the seller/lessor and for property consulting and advisory services when performance obligations under the relevant service contract are completed and the customer accepts the contracted deliverable.

### *Property Operation Services*

Revenue derived from property operation services is recognized when the related services are provided. In early 2011, we commenced to reorganize our property operation services business and since then, have been providing property operation services through our subsidiary Colour Life and its subsidiaries. We have designated “Colour Life” as our brand for middle-to-high end property management and property community services. Property operation services include property management, building equipment for installations, maintenance, repair and other value-added services, such as secondary property brokerage services after our disposal of Xingyan Property Consultancy, for our properties as well as properties developed by other developers. The time lag between when the invoices are sent to clients and the time of collection is reflected in “trade and other receivables” on our consolidated statement of financial position.

### *Hotel Services*

Revenue derived from hotel management and related services is recognized when such services are provided. We started providing hotel services in December 2008 through our subsidiaries, Shenzhen Caiyue Hotel Management Co., Ltd. and Shenzhen Caiyue Hotel Co., Ltd. Since then, we have expanded this business segment through cooperation with well-known hotel management groups and have also established our private brand of boutique hotels. We expect our revenue from hotel services will continue to increase in the future as we complete our hotel projects and commence operation of additional hotels, including our own boutique hotels that are currently under development.

### *Cost of Sales*

Cost of sales for our property development business primarily represents the costs we incur directly for our property development activities. The principal component of cost of sales for our property development business is the cost of properties sold, which includes the direct cost of construction, costs of land and capitalized finance costs on related borrowings during the period of construction.

Construction costs include all of the costs for the design and construction of a project, including payments to third-party contractors and designers and costs of construction materials. Historically, construction material costs, which are generally included in the payments to the construction contractors, particularly the cost of steel and cement, have been a major cause of fluctuations in our construction costs. Price movements of other supplies in relation to property developments, including elevators,

interior decoration materials and air conditioning systems, may also increase our construction costs. Costs associated with design and construction of the foundation are another major component of our construction costs and will vary according to the area and height of the buildings as well as the geological conditions of the site. Therefore, construction costs of a property development may be higher if the conditions of a site require more complex designs and processes or more expensive materials in order to provide the necessary foundation support. In addition, with the PRC government's recent policies aiming to enhance the protection for employees and increased employers' liability in many circumstances, our labor costs may increase in the future which in turn will increase our construction costs.

Costs of land include costs relating to the acquisition of rights to occupy, use and develop land, and primarily represent land premiums incurred in connection with land grants from the PRC government or land obtained in the secondary market by transfer, cooperative arrangement, corporate acquisition or otherwise. Our costs of land are influenced by a number of factors, including the location of the property, the timing of the acquisition, the project's plot ratios, the method of acquisition and changes in PRC regulations. We may also be required to pay demolition and resettlement costs.

We capitalize a significant portion of our finance costs to the extent that such costs are directly attributable to the acquisition and construction of a project. In general, we capitalize finance costs incurred from the commencement of the planning and design of a project, which typically precedes the receipt of a construction works commencement permit, until the completion of construction. For any given project, the finance costs incurred after the end of the month in which construction on the project is completed are not capitalized, but are instead accounted for as finance costs in the period in which they are incurred.

Our cost of sales for our property investment, property agency services, property operation services and hotel services primarily consists of direct costs related to such business activities, which primarily include, depending on the type of businesses, salaries and commissions, costs of rental, utility and consumable products for our on-site sales offices for our primary property agency services, certain office expenses and advertising and marketing expenses.

The table below sets forth information relating to our cost of sales for each of our business segments and as a percentage of total cost of sales for the periods indicated:

	For the year ended December 31,						
	2010		2011		2012		
	(RMB)	(%)	(RMB)	(%)	(RMB)	(US\$)	(%)
	(unaudited)						
	(in thousands, except percentages)						
<b>Property development</b>							
Construction costs . . . . .	1,917,000	75.3	2,151,188	67.2	2,706,019	434,346	72.9
Land use rights . . . . .	469,309	18.4	799,530	25.0	682,982	109,626	18.4
Capitalized finance costs . .	58,113	2.3	90,677	2.8	87,273	14,008	2.4
Total property development . .	2,444,421	96.0	3,041,385	95.0	3,476,274	557,980	93.7
Property investment . . . . .	4	0.0	2,412	0.1	7,139	1,145	0.2
Property agency services . . . .	47,431	1.9	12,407	0.4	6,953	1,116	0.2
Property operation services . .	46,655	1.8	93,321	2.9	125,694	20,175	3.4
Hotel services . . . . .	7,928	0.3	36,625	1.1	93,728	15,044	2.5
Others . . . . .	—	0.0	14,500	0.5	—	—	—
Total . . . . .	<u>2,546,440</u>	<u>100.0</u>	<u>3,200,650</u>	<u>100.0</u>	<u>3,709,788</u>	<u>595,460</u>	<u>100.0</u>

### ***Changes in Fair Value of Investment Properties***

Investment properties are properties held to earn rental income and/or for capital appreciation. On initial recognition, investment properties are measured at cost, including any directly attributable expenditure. Subsequent to initial recognition, investment properties are measured at their fair values using the fair value model. Property that is being constructed or developed for future use as an investment property is classified as an investment property. We have concluded the fair value of the investment properties under development cannot be measured reasonably, therefore, our investment properties under development continue to be measured at cost until such time as fair value can be determined or construction is completed. Our investment properties are currently comprised primarily of office units, retail spaces and car parking spaces. Once an investment property is sold or if the investment property is permanently withdrawn from use and no future economic benefits are expected, gains or losses on disposals of such investment property are recognized as “Gain/loss on disposal of investment properties.”

Gains or losses arising from changes in the fair values of investment properties are included in our consolidated statements of comprehensive income in the period in which they arise. Investment properties are initially recognized at cost, subsequent to initial recognition, investment properties are stated on our consolidated statement of comprehensive income as non-current asset at fair value, which reflects market conditions as of the date of our consolidated statement of comprehensive income. The valuation is determined by independent and qualified professionals and involves the exercise of professional judgment on the part of the valuation professionals and the use of certain assumptions, such as making reference to comparable sales evidence available in the market.

### ***Selling and Distribution Expenses***

Selling and distribution expenses include sales commissions, advertising and promotion expenses related to the sale of our properties and the promotion of our brand and services, which include advertisements on television and in newspapers, magazines, on billboards, promotional offers made directly to our customers and certain other promotional events.

### ***Administrative Expenses***

Administrative expenses include staff costs, office rental payments, depreciation and amortization, travelling and entertainment expenses, professional fees and general office expenses.

### ***Finance Costs***

Finance costs consist primarily of interest costs on borrowings net of capitalized finance costs. We capitalize a portion of our finance costs to “properties under development for sale,” “investment properties under development,” “construction in progress” and “land development expenditure” on our consolidated statements of financial position to the extent that such costs are directly attributable to the development of a project. Finance costs fluctuate from period to period due primarily to fluctuations in our level of outstanding indebtedness and the interest rates on such indebtedness. Since the development period for a property development does not necessarily coincide with the repayment period of the relevant loan, not all of the finance costs related to a property development can be capitalized. As a result, the period to period fluctuation of our finance costs is also attributable to the amount and timing of capitalization. See “— Critical Accounting Policies — Capitalized Finance Costs.”

### ***Income Tax Expenses***

Income tax expenses represent PRC enterprise income tax and LAT payable by our subsidiaries in China. For 2010, 2011 and 2012, our effective tax rate (income tax expenses divided by profit before tax) was 46.3%, 48.3% and 52.8%, respectively.

The PRC enterprise income tax has been calculated at the applicable tax rate on the assessable profits for each of 2010, 2011 and 2012. Under the EIT Law that became effective on January 1, 2008, a uniform income tax rate of 25% was imposed on the taxable income of both domestic enterprises and foreign-invested enterprises, enterprises that were subject to an enterprise income tax rate lower than 25% may continue to enjoy the lower rate and gradually transition to the new tax rate within five years after implementation of the EIT Law. As a result of the EIT Law, the applicable enterprise income tax rate for our subsidiaries in Shenzhen was 22% and 24% in 2010 and 2011, respectively, and 25% for 2012 onwards. In addition, the applicable enterprise income tax rate for our subsidiaries in Chengdu was 15% in 2010 and has since 2011 transitioned to 25%. The income tax rate for our other subsidiaries in China is also 25%.

LAT expenses represent provisions for the estimated LAT payable in relation to our properties delivered during a period. Property developers in China that receive income from the sale or transfer of state-owned land use rights, buildings and their attached facilities are subject to LAT at progressive rates ranging from 30% to 60% of the “appreciated value of the property.” However, no LAT is payable for the sale of ordinary residential properties if the appreciation value does not exceed 20% of the “total deductible items,” as such term is defined in the relevant tax laws. Whether a property qualifies for the ordinary standard residential property exemption is determined by the local government taking into consideration the property’s plot ratio, aggregate GFA and sale price.

Deferred tax is recognized on differences between the carrying amounts of assets and liabilities in the consolidated financial statements and the corresponding tax base used in the computation of taxable profit. Deferred tax liabilities are generally recognized for all taxable temporary differences. Deferred tax assets are generally recognized to the extent that it is probable that taxable profits will be available against which those deductible temporary differences can be utilized. Such assets and liabilities are not recognized if the temporary difference arises from goodwill or from the initial recognition (other than in a business combination) of other assets and liabilities in a transaction that affects neither the taxable profit nor the accounting profit.

Deferred tax liabilities are recognized for taxable temporary differences associated with investments in subsidiaries and associates, except where the Group is able to control the reversal of the temporary difference and it is probable that the temporary difference will not reverse in the foreseeable future. Deferred tax assets arising from deductible temporary differences associated with such investments are only recognized to the extent that it is probable that there will be sufficient taxable profits against which to utilise the benefits of the temporary differences and they are expected to reverse in the foreseeable future.

The carrying amount of deferred tax assets is reviewed at the end of the reporting period and reduced to the extent that it is no longer probable that sufficient taxable profits will be available to allow all or part of the asset to be recovered. Deferred tax assets and liabilities are measured at the tax rates that are expected to apply in the period in which the liability is settled or the asset is realized, based on tax rate (and tax laws) that have been enacted or substantively enacted by the end of the reporting period.

The measurement of deferred tax liabilities and assets reflects the tax consequences that would follow from the manner in which the Group expects, at the end of the reporting period, to recover or settle the carrying amount of its assets and liabilities.

### **Critical Accounting Policies**

We have identified certain accounting policies that are significant to the preparation of our consolidated financial statements. Our significant accounting policies, which are important for an understanding of our financial condition and results of operation, are set forth in detail in Note 3 to our consolidated financial statements included in this offering memorandum. Some of our accounting policies involve subjective assumptions and estimates, as well as complex judgments relating to accounting items such as revenue recognition, cost or expense allocation and provision. In each case, the determination of these items requires management judgments based on information and financial data that may change in future periods. When reviewing our consolidated financial statements, you should consider (i) our selection of critical accounting policies; (ii) the judgment and other uncertainties

affecting the application of such policies; and (iii) the sensitivity of reported results to changes in conditions and assumptions. We set forth below those accounting policies that we believe involve the most significant estimates and judgments used in the preparation of our consolidated financial statements.

### ***Revenue Recognition***

Revenue is measured at the fair value of the consideration received or receivable and represents amounts receivable for properties sold and services provided in the normal course of business, net of discounts and sales-related taxes.

#### *Sales of properties*

Revenue from sales of properties in the ordinary course of business is recognized when the respective properties have been completed and delivered to the buyers. Deposits and installments received from purchasers prior to meeting the above criteria for revenue recognition are included in the consolidated statement of financial position under current liabilities.

When the completed properties are sold in exchange for dissimilar goods or services, the exchange is regarded as a transaction which generates revenue. The revenue is measured at the fair value of the goods or services received, adjusted by the amount of any cash or cash equivalents transferred.

#### *Agency fee, service income, management fee, parking fee and consultation fee*

Agency fee, service income, management fee, parking fee and consultation fee are recognized when services are provided.

#### *Contract revenue*

Contract revenue from installation contract is recognized when the outcome of the contract can be estimated reliably and the stage of completion at the end of reporting period can be measured reliably. Revenue from construction contracts is recognized on the percentage of completion method, measured by reference to the proportion that billings agreed with the customer to date relative to the estimated total revenue for each contract. When the outcome of a construction contract cannot be estimated reliably, revenue is recognized only to the extent of contract cost incurred that it is probable to be recoverable.

#### *Hotel operation*

Revenue from hotel accommodation, hotel management and related services, food and beverage sales and other ancillary services is recognized when the services are rendered.

#### *Interest income*

Interest income from a financial asset is recognized when it is probable that the economic benefits will flow to the Group and the amount of income can be measured reliably. Interest income is accrued on a time basis, by reference to the principal outstanding and at the effective interest rate applicable, which is the rate that exactly discounts estimated future cash receipts through the expected life of the financial asset to that asset's net carrying amount on initial recognition.

#### *Government grants*

Government grants are not recognized until there is reasonable assurance that the Group will comply with the conditions attaching to them and that the grants will be received.

Government grants are recognized in profit or loss on a systematic basis over the periods in which the Group recognizes as expenses the related costs for which the grants are intended to compensate.



Government grants that are receivable as compensation for expenses or losses already incurred or for the purpose of giving immediate financial support to the Group with no future related costs are recognized in profit or loss in the periods in which they become receivable.

### ***Properties for Sale***

Completed properties and properties under development for sale in the ordinary course of business are included in current assets and stated at the lower of cost and net realisable value. Cost includes the cost of land, development expenditure, borrowing costs capitalized in accordance with the Group's accounting policy, and other attributable expenses.

Net realizable value represents the estimated selling price for properties for sale less all estimated costs of completion and costs necessary to make the sale.

The Group transfers a property from inventories to investment property when there is a change of intention to hold the property to earn rentals and/or for capital appreciation rather than for sale in the ordinary course of business, which is evidenced by the commencement of an operating lease to another party. Any difference between the fair value of the property at the date of transfer and its previous carrying amount is recognized in profit or loss.

### ***Investment Properties***

Investment properties are properties held to earn rentals and/or for capital appreciation, including properties under construction for such purposes.

Investment properties are initially measured at cost, including any directly attributable expenditure. Subsequent to initial recognition, investment properties are measured at their fair values using the fair value model. Gains or losses arising from changes in the fair value of investment property are included in profit or loss for the periods in which they arise.

Construction costs incurred for investment properties under construction are capitalized as part of the carrying amount of the investment properties under construction.

Property that is being constructed or developed for future use as investment property is classified as investment property. If the fair value cannot be reliably determined, the investment property under development will be measured at cost until such time as fair value can be determined or construction is completed.

An investment property is derecognized upon disposal or when the investment property is permanently withdrawn from use and no future economic benefits are expected from its disposals. Any gain or loss arising on derecognition of the asset (calculated as the difference between the net disposal proceeds and the carrying amount of the asset) is included in the profit or loss in the period in which the item is derecognized.

### ***Borrowing Costs***

Borrowing costs directly attributable to the acquisition, construction or production of qualifying assets, which are assets that necessarily take a substantial period of time to get ready for their intended use or sale, are added to the cost of those assets until such time as the assets are substantially ready for their intended use or sale.

All other borrowing costs are recognized in profit or loss in the periods in which they are incurred.

## Results of Operations

The following table sets forth our results of operations for the periods indicated which are derived from the consolidated statements of comprehensive income included in this offering memorandum. Our historical results presented below are not necessarily indicative of future results.

	For the year ended December 31,			
	2010 (RMB)	2011 (RMB)	2012 (RMB)	2012 (US\$) (unaudited)
	(in thousands)			
<b>Revenue</b> . . . . .	4,471,234	5,592,350	6,230,050	999,992
Cost of sales and services . . . . .	(2,546,440)	(3,200,650)	(3,079,778)	(595,460)
<b>Gross profit</b> . . . . .	1,924,794	2,391,700	2,520,272	404,532
Other income, gains and losses . . . . .	32,199	46,922	31,800	5,104
Change in fair value of investment properties . . . . .	320,461	182,980	167,876	26,946
Recognition of change in fair value of completed properties for sale upon transfer to investment properties . . . . .	67,326	191,142	330,257	53,010
Selling and distribution expenses . . . . .	(131,278)	(262,433)	(314,100)	(50,417)
Administrative expenses . . . . .	(238,724)	(309,972)	(291,966)	(46,864)
Finance costs . . . . .	(180,131)	(108,471)	(57,698)	(9,261)
Impairment loss recognized in respect of goodwill . . .	(5,375)	(1,321)	–	–
Share of results of associates . . . . .	406	171	417	67
Gain on disposal of an associate . . . . .	–	3,533	–	–
Gain on disposal of a subsidiary . . . . .	–	17,589	–	–
<b>Profit before taxation</b> . . . . .	1,789,678	2,151,840	2,386,858	383,117
Income tax expense . . . . .	(828,708)	(1,038,344)	(1,261,209)	(202,438)
<b>Profit for the year/period</b> . . . . .	960,970	1,113,496	1,125,649	180,679
<b>Other comprehensive income (expense)</b>				
Surplus on revaluation of properties . . . . .	–	11,795	45,708	7,337
Deferred taxation liability arising from revaluation of properties . . . . .	–	(4,851)	(14,633)	(2,349)
Other comprehensive income for the year/period (net of income tax) . . . . .	–	6,944	31,075	4,988
<b>Total comprehensive income for the year/period</b> . . . . .	960,970	1,120,440	1,156,724	185,667
Profit for the year/period attributable to:				
Owners of the Company . . . . .	807,281	1,057,479	1,139,241	182,861
Non-controlling interests . . . . .	153,689	56,017	(13,592)	(2,182)
	960,970	1,113,496	1,125,649	180,679
Total comprehensive income attributable to:				
Owners of the Company . . . . .	807,281	1,064,423	1,163,210	186,708
Non-controlling interests . . . . .	153,689	56,017	(6,486)	(1,041)
	960,970	1,120,440	1,156,724	185,667

***Comparison of the Year Ended December 31, 2012 to the Year Ended December 31, 2011***

**Revenue.** Our revenue increased by 11.4% to RMB6,230.1 million (US\$1,000.0 million) in 2012 from RMB5,592.4 million in 2011. This was primarily due to an increase in revenue from our property development business as a result of the increase in total GFA delivered.

The below table and discussion set forth the revenue attributable to each of our business segments for the years indicated:

	For the year ended December 31,				
	2011		2012		
	(RMB)	(%)	(RMB)	(US\$)	(%)
(unaudited)					
(in thousands, except percentages)					
Property development . . . . .	5,396,289	96.5	5,885,314	944,658	94.5
Property investment . . . . .	37,887	0.7	90,266	14,489	1.4
Property agency services . . . . .	10,571	0.2	14,470	2,322	0.2
Property operation services . . . . .	124,895	2.2	184,683	29,644	3.0
Hotel services . . . . .	22,708	0.4	55,317	8,879	0.9
Total . . . . .	<u>5,592,350</u>	<u>100.0</u>	<u>6,230,050</u>	<u>999,992</u>	<u>100.0</u>

**Property development.** Revenue derived from property development increased by 9.1% to RMB5,885.3 million (US\$944.7 million) in 2012, from RMB5,396.3 million in 2011. This increase was primarily due to an increase in total GFA delivered. For information on changes in selling prices of our properties sold in the respective periods, see “— Certain Income Statement Items — Revenue — Property Development.”

**Property investment.** Revenue derived from property investment increased by 138.3% to RMB90.3 million (US\$14.5 million) in 2012, from RMB37.9 million in 2011. This increase was primarily due to an increase in the number of investment properties and an increase in occupancy rate.

**Property agency services.** Revenue derived from property agency services increased by 36.9% to RMB14.5 million (US\$2.3 million) in 2012, from RMB10.6 million in 2011. We disposed of Xingyan Property Consultancy, our subsidiary engaged in the property agency services, in February 2011 in order to focus on our other major business segments. However, we retained secondary property brokerage services provided by Xingyan Property Consultancy in our property operation services as a value-added service.

**Property operation services.** Revenue derived from property operation services increased by 47.9% to RMB184.7 million (US\$29.6 million) in 2012, from RMB124.9 million in 2011. This increase was primarily due to an increase in the GFA of properties that we managed and coverage of value-added service that we provided to customers during 2012.

**Hotel services.** Revenue derived from hotel services increased by 143.6% to RMB55.3 million (US\$8.9 million) in 2012, from RMB22.7 million in 2011. This increase was primarily due to an increase in the occupancy rate of our hotels during 2012.

**Cost of sales and services.** Our cost of sales increased by 15.9% to RMB3,709.8 million (US\$595.5 million) in 2012, from RMB3,200.7 million in 2011. This increase was primarily due to an increase in total GFA delivered in 2012.

**Gross profit.** As a result of the foregoing, our gross profit increased by 5.4% to RMB2,520.3 million (US\$404.5 million) in 2012, from RMB2,391.7 million in 2011. Our gross margin in 2012 was 40.5% compared to 42.8% in 2011. The higher gross margin in 2011 was primarily due to contributions from three projects in Shenzhen, Chengdu and Yixing, respectively, all of which were completed in 2011.

**Other income, gains and losses.** Our other income, gains and losses decreased by 32.2% to RMB31.8 million (US\$5.1 million) in 2012, from RMB46.9 million in 2011. This decrease was primarily due to an exchange gain of RMB7.5 million in 2012 compared to RMB28.6 million in 2011. The exchange gain was due to the appreciation of the Renminbi against the U.S. dollar related to the translation of our U.S. dollar-denominated bank borrowings, the 2010 Notes and the 2012 Notes.

**Change in fair value of investment properties.** Our gain on fair value changes of investment properties decreased by 8.3% to RMB167.9 million (US\$26.9 million) in 2012, from RMB183.0 million in 2011. This decrease was primarily due to a larger amount of transfer upon completion of properties under development to investment properties in 2011.

**Recognition of change in fair value of completed properties for sale upon transfer to investment properties.** Our recognition of change in fair value of completed properties for sale upon transfer to investment properties increased to RMB330.3 million (US\$53.0 million) in 2012, from RMB191.1 million in 2011. This increase was primarily due to the increase in the GFA of properties for sales completed in 2012 that we transferred to investment properties as compared to 2011.

**Selling and distribution expenses.** Our selling and distribution expenses increased by 19.7% to RMB314.1 million (US\$50.4 million) in 2012, from RMB262.4 million in 2011. The increase was primarily due to an increase in general sales, marketing and advertising activities resulting from an increase in the number of properties that were pre-sold in 2012 as compared to that in 2011.

**Administrative expenses.** Our administrative expenses decreased by 5.8% to RMB292.0 million (US\$46.9 million) in 2012, from RMB310.0 million in 2011. This decrease was primarily due to the implementation of an effective budgeting system in 2012. As a result, we are able to utilize and allocate the resources much more effectively than the previous year.

**Finance costs.** Our finance costs decreased by 46.8% to RMB57.7 million (US\$9.3 million) in 2012, from RMB108.5 million in 2011. Most of our bank loans were used for project construction and the decrease in finance costs was primarily due to the increase in our interest capitalization rate.

**Share of results of associates.** Our share of profit of associates was RMB0.2 million and RMB0.4 million (US\$0.07 million) in 2011 and 2012, respectively.

**Income tax expense.** Our income tax expense increased by 21.5% to RMB1,261.2 million (US\$202.4 million) in 2012, from RMB1,038.3 million in 2011. The increase was primarily due to an increase in enterprise income tax and land appreciation tax as a result of the increase in properties sold and recognized in 2012 as compared to that in 2011.

**Other comprehensive income (net of income tax).** Our other comprehensive income (net of income tax) increased by 347.5% to RMB31.1 million (US\$5.0 million) in 2012, from RMB6.9 million in 2011. This increase was primarily due to an increase in surplus on revaluation of properties, partially offset by an increase in deferred taxation liability arising from the revaluation of properties.

**Total comprehensive income for the year.** As a result of the foregoing, total comprehensive income for the year increased by 3.2% to RMB1,156.7 million (US\$185.7 million) in 2012, from RMB1,120.4 million in 2011.

#### **Comparison of the Year Ended December 31, 2011 to the Year Ended December 31, 2010**

**Revenue.** Our revenue increased by 25.1% to RMB5,592.4 million (US\$880.3 million) in 2011 from RMB4,471.2 million in 2010. This was primarily due to an increase in revenue derived from our property development business.

The below table and discussion set forth the revenue attributable to each of our business segments for the years indicated:

	For the year ended December 31,			
	2010		2011	
	(RMB)	(%)	(RMB)	(%)
	(in thousands, except percentages)			
Property development . . . . .	4,320,413	96.6	5,396,289	96.5
Property investment . . . . .	17,727	0.4	37,887	0.7
Property agency services . . . . .	36,845	0.8	10,571	0.2
Property operation services . . . . .	89,228	2.0	124,895	2.2
Hotel services . . . . .	7,021	0.2	22,708	0.4
Total . . . . .	<u>4,471,234</u>	<u>100.0</u>	<u>5,592,350</u>	<u>100.0</u>

*Property development.* Revenue derived from property development increased by 24.9% to RMB5,396.3 million (US\$849.4 million) in 2011, from RMB4,320.4 million in 2010. This increase was primarily due to an increase in total GFA delivered and an increase in the average selling price of properties delivered. For information on changes in selling prices of our properties delivered in the respective years, see “— Certain Income Statement Items — Revenue — Property Development.”

*Property investment.* Revenue derived from property investment increased by 113.7% to RMB37.9 million (US\$6.0 million) in 2011 from RMB17.7 million in 2010. This increase was primarily due to an increase in the number of investment properties in 2011 as compared to 2010.

*Property agency services.* Revenue derived from property agency services decreased by 71.3% to RMB10.6 million (US\$1.7 million) in 2011 from RMB36.8 million in 2010. This decrease was primarily due to the disposal of Xingyan Property Consultancy, our subsidiary engaged in the property agency services, in February 2011. We disposed of Xingyan Property Consultancy to focus on our other major business segments and retained secondary property brokerage services provided by Xingyan Property Consultancy in our property operation services as a value-added service.

*Property operation services.* Revenue derived from property operation services increased by 40.0% to RMB124.9 million (US\$19.7 million) in 2011 from RMB89.2 million in 2010. This increase was primarily due to an increase in the GFA of properties that we managed during 2011.

*Hotel services.* Revenue derived from hotel services increased by 223.4% to RMB22.7 million (US\$3.6 million) in 2011 from RMB7.0 million in 2010. This increase was primarily due to an increase in the occupancy rate of our hotels during 2011.

*Cost of sales.* Our cost of sales increased by 25.7% to RMB3,200.7 million (US\$503.8 million) in 2011 from RMB2,546.4 million in 2010. This increase was primarily due to an overall increase in construction costs and finance costs in line with the increase in the total GFA delivered in 2011 as compared to 2010.

*Gross profit.* As a result of the foregoing, our gross profit increased by 24.3% to RMB2,391.7 million (US\$376.5 million) in 2011 from RMB1,924.8 million in 2010, while our gross margin remained relatively stable at 42.8% in 2011 as compared to 43.0% in 2010.

*Other income, gains and losses.* Our other income, gains and losses increased by 45.7% to a gain of RMB47.0 million (US\$7.4 million) in 2011 from a gain of RMB32.2 million in 2010. This increase was primarily due to a net exchange gain of RMB28.6 million (US\$4.5 million) in 2011 as compared to RMB1.6 million in 2010. The exchange gain was due to the appreciation of the Renminbi against the U.S. dollar related to the translation of our U.S. dollar-denominated bank borrowings and the 2010 Notes.

*Change in fair value of investment properties.* Our gain on fair value changes of investment properties decreased by 42.9% to RMB183.0 million (US\$28.8 million) in 2011 from RMB320.5 million

in 2010. This decrease was primarily due to a larger amount of transfer upon completion of properties under development to investment properties in 2010.

**Recognition of change in fair value of completed properties for sale upon transfer to investment properties.** Our recognition of change in fair value of completed properties for sale upon transfer to investment properties increased from RMB67.3 million in 2010 to RMB191.1 million in 2011. This increase was primarily due to the increase in the GFA of properties for sales completed in 2011 that we transferred to investment properties as compared to 2010.

**Selling and distribution expenses.** Our selling and distribution expenses increased by 99.9% to RMB262.4 million (US\$41.3 million) in 2011 from RMB131.3 million in 2010. This increase was primarily due to an increase in general sales, marketing and advertising activities resulting from an increase in the number of properties that were pre-sold in 2011 as compared to that in 2010.

**Administrative expenses.** Our administrative expenses increased by 29.8% to RMB310.0 million (US\$48.8 million) in 2011 from RMB238.7 million in 2010. This increase was primarily due to an increase in the number of offices and staff cost in new locations as a result of our expansion.

**Impairment loss recognized in respect of goodwill.** In 2011, we recognized an impairment loss of RMB1.3 million (US\$0.2 million) in respect of goodwill associated with our acquisition of Tianjin Xingtang Property Management Company Limited, Huizhou Youling Property Management Company Limited and Shenzhen Robert Housekeeper Property Management Company Limited. In 2010, we recognized an impairment loss of RMB5.4 million in respect of goodwill associated with our acquisition of Shenzhen Hui Gang Property Management Company Limited.

**Share of results of associates.** Our share of gain of associates was RMB0.4 million and RMB0.2 million (US\$0.03 million) in 2010 and 2011, respectively.

**Finance costs.** Our finance costs decreased by 39.8% to RMB108.5 million (US\$17.1 million) in 2011 from RMB180.1 million in 2010. This decrease was primarily due to an increase in interests capitalized in properties under development for sale, which was partially offset by an increase in interest expense as a result of an increase in borrowing.

**Gain on disposal of an associate.** In 2011, we recorded a gain on disposal of an associate in the amount of RMB3.5 million (US\$0.6 million). We did not dispose of any associate in 2010.

**Gain on disposal of a subsidiary.** In 2011, we recorded a gain on disposal of a subsidiary, Xingyan Property Consultancy, in the amount of RMB17.6 million (US\$2.8 million). We did not dispose of any subsidiary in 2010.

**Income tax expense.** Our income tax expense increased by 25.3% to RMB1,038.3 million (US\$163.4 million) in 2011 from RMB828.7 million in 2010. This increase was primarily due to an increase in enterprise income tax and land appreciation tax as a result of the increase in properties sold and recognized in 2011 as compared to that in 2010.

**Other comprehensive income (net of income tax).** In 2011, we recorded other comprehensive income (net of income tax) in the amount of RMB6.9 million (US\$1.1 million), comprised of a surplus on revaluation of properties of RMB11.8 million (US\$1.9 million), partially offset by a deferred taxation liability arising from the revaluation of properties of RMB4.9 million (US\$0.8 million). No other comprehensive income (expense) was recorded in 2010.

**Total comprehensive income for the year.** As a result of the foregoing, total comprehensive income for the year increased by 16.6% to approximately RMB1,120.4 million (US\$176.4 million) in 2011 from approximately RMB961.0 million in 2010. Our net profit margin increased to 20.0% in 2011 from 21.5% in 2010.

## Liquidity and Capital Resources

### Cash Flows

The following table sets forth our net cash flow for the periods indicated:

	For the year ended December 31,			
	2010	2011	2012	
	(RMB)	(RMB)	(RMB)	(US\$)
	(unaudited)			
	(in thousands)			
Net cash (used in) from operating activities . . . . .	(1,631,947)	(203,578)	846,004	135,793
Net cash used in investing activities . . . . .	(1,733,615)	(856,230)	(1,262,475)	(202,641)
Net cash from (used in) financing activities . . . . .	2,081,274	(270,274)	2,183,377	350,456
Net increase (decrease) in cash and cash equivalents . . . . .	(1,284,288)	(1,330,082)	1,767,906	283,768
Cash and cash equivalents at end of year . . . . .	2,371,452	1,021,355	2,788,106	447,522

### Cash Flows from Operating Activities

Our cash used in operating activities principally comprises amounts we pay for our property development activities, which are reflected on our consolidated statements of financial position as an increase in our properties for sales. Our cash provided by operating activities is generated principally from the proceeds from the sales of our properties, including pre-sales of properties under development, as well as commissions and fees received from our property agency services, property operation services and hotel services businesses.

In 2012, our net cash from operating activities was RMB846.0 million (US\$135.8 million). Cash from investing activities in 2012 primarily consisted of profit before taxation of RMB2,386.9 million (US\$383.1 million) and an increase in deposits received for sale of properties of RMB1,567.1 million (US\$251.5 million), partially offset by an increase in trade and other receivables of RMB963.0 million (US\$154.6 million), an increase in properties for sale of RMB576.6 million (US\$92.5 million), an addition to prepared lease payments of RMB506.9 million (US\$81.4 million), interest paid of RMB510.3 million (US\$81.9 million), LAT paid of RMB244.6 million (US\$39.3 million) and enterprise income tax paid of RMB191.8 million (US\$30.8 million).

In 2011, our net cash used in operating activities was RMB203.6 million. Cash used in operating activities in 2011 primarily consisted of an increase in properties for sales of RMB1,229.6 million, an increase in land development expenditure of RMB910.0 million, interest paid of RMB436.9 million, LAT paid of RMB326.7 million and enterprise income tax paid of RMB218.7 million, partially offset by a profit before taxation of RMB2,151.8 million, an increase in deposits received for sale of properties of RMB784.9 million and an increase in trade and other payables of RMB519.2 million.

In 2010, our net cash used in operating activities was RMB1,631.9 million. Cash used in operating activities in 2010 primarily consisted of an increase in deposits paid for acquisition of land use rights of RMB763.1 million, addition to prepaid lease payments of RMB700.7 million, an increase in properties for sale of RMB687.9 million, a decrease in deposits received for sale of properties of RMB546.2 million, an increase in land development expenditure of RMB393.8 million, an increase in trade and other receivables of RMB338.8 million and interest paid of RMB306.0 million, partially offset by a profit before taxation of RMB1,789.7 million and an increase in trade and other payables of RMB731.4 million.

### *Cash Flows from Investing Activities*

In 2012, our net cash used in investing activities was RMB1,262.5 million (US\$202.6 million). Cash used in investing activities in 2012 included: acquisition of assets and liabilities through acquisition of subsidiaries of RMB458.1 million (US\$73.5 million), an increase in restricted bank deposits of RMB392.5 million (US\$63.0 million), additions to investment properties of RMB149.6 million (US\$24.0 million) and purchase of property plant and equipment of RMB134.8 million (US\$21.6 million).

In 2011, our net cash used in investing activities was RMB856.2 million. The primary factors affecting net cash used in investing activities in 2011 included: additions to investment properties of RMB274.0 million, an increase in restricted bank deposits of RMB230.0 million, acquisition of assets and liabilities through acquisition of subsidiaries of RMB180.2 million and purchase of property, plant and equipment of RMB155.9 million.

In 2010, our net cash used in investing activities was RMB1,733.6 million. The primary factors affecting net cash used in investing activities in 2010 included: acquisition of assets and liabilities through acquisition of subsidiaries of RMB1,411.3 million and additions to investment properties of RMB330.5 million.

### *Cash Flows from Financing Activities*

In 2012, our net cash from financing activities was RMB2,183.4 million (US\$350.5 million). The primary factors affecting net cash from financing activities in 2012 included: net borrowings raised of RMB3,356.8 million (US\$538.8 million) and net proceeds from the issuance of the 2010 Notes and the 2012 Notes of RMB1,530.3 million (US\$245.6 million), partially offset by repayment of borrowings of RMB2,540.0 million (US\$407.7 million) and dividend paid of RMB168.9 million (US\$27.1 million).

In 2011, our net cash used in financing activities was RMB270.3 million. The primary factors affecting net cash used in financing activities in 2011 included: repayment of borrowings of RMB2,738.6 million, acquisition of additional interest in subsidiaries of RMB344.8 million and dividends paid to shareholders of RMB165.9 million, partially offset by new borrowings raised of RMB2,755.9 million and proceeds from the issue of shares of RMB332.4 million.

In 2010, our net cash from financing activities was RMB2,081.3 million. The primary factors affecting net cash from financing activities in 2010 included: new borrowings raised of RMB3,553.5 million and net proceeds from the issuance of the 2010 Notes of RMB794.1 million, partially offset by repayment of borrowings of RMB2,190.1 million.

### *Capital Resources*

Property developments require substantial capital investment for land acquisition and construction and may take months or years before positive cash flow can be generated. We principally fund our property developments from internal funds, borrowings from banks, proceeds from sales and pre-sales of our properties, capital contributions from shareholders and proceeds from issuance of equity and debt securities, such as our IPO in November 2009, issuance of the 2010 Notes in May 2010 and issuance of the 2012 Notes in September 2012. Our financing methods may vary from project to project and are subject to limitations imposed by PRC regulations and monetary policies.

### *Bank Balances and Cash*

As of December 31, 2010, 2011 and 2012, our bank balances and cash amounted to RMB2,371.5 million, RMB1,021.4 million and RMB2,788.1 million (US\$447.5 million), respectively. Our bank balances and cash increased by RMB1,766.7 million (US\$283.6 million), or 173.0%, to RMB2,788.1 million (US\$447.5 million) as of December 31, 2012 from RMB1,021.4 million as of December 31, 2011 primarily due to net cash inflow from financing activities for the year, partially offset by net cash used in operating and investing activities. Our bank balances and cash decreased by RMB1,350.1 million, or 56.9%, to RMB1,021.4 million as of December 31, 2011 from RMB2,371.5 million as of December 31, 2010 primarily due to net cash outflow in operating, investing and financing activities for the year.



## Borrowings

Our borrowings primarily consist of loans from commercial banks and other financial institutions. As of December 31, 2012, we had an aggregate bank borrowings of RMB5,002.4 million (US\$802.9 million), of which substantially all was denominated in RMB and approximately RMB916.6 million and RMB137.8 million were denominated in U.S. dollars and Hong Kong dollars, respectively. Substantially all of our borrowings are secured by land use rights and properties of our Group. Subsequent to December 31, 2012, we issued the January 2013 Notes in the aggregate principal amount of US\$250 million on January 22, 2013. We have also, since December 31, 2012, in the ordinary course of business, entered into additional financing arrangements to finance our property developments and for general corporate purposes.

Our borrowings have a range of maturities from less than one year to more than five years. As of December 31, 2012, the interest rates for our fixed rate borrowings ranged from 12.6% to 18.0% per annum and our variable rate borrowings have variable interest rates at either the Hong Kong Interbank Offering Rate plus 2.0%, the London Interbank Offered Rate plus 2%, or the benchmark lending rate of the PBOC plus 2.6% or minus 0.4% per annum.

The following table sets forth the level of our borrowings and their respective maturity profiles as of the dates indicated.

	As of December 31,			
	2010 (RMB)	2011 (RMB)	2012 (RMB) (US\$)	
	(unaudited)			
	(in thousands)			
Bank loans . . . . .	4,306,986	4,273,002	5,002,407	802,942
Other loans . . . . .	468,000	468,000	550,000	88,281
	<u>4,774,986</u>	<u>4,741,002</u>	<u>5,552,407</u>	<u>891,223</u>
Secured. . . . .	4,206,986	4,711,002	3,951,677	634,288
Unsecured. . . . .	568,000	30,000	1,600,730	256,935
	<u>4,774,986</u>	<u>4,741,002</u>	<u>5,552,407</u>	<u>891,223</u>
Carrying amount repayable:				
Within one year . . . . .	1,933,270	1,896,308	1,860,653	298,655
More than one year, but not exceeding two years . . . . .	1,860,000	1,216,000	1,910,568	306,667
More than two years, but not exceeding five years . . .	875,861	936,824	1,427,002	229,050
More than five years. . . . .	105,855	691,870	354,184	56,851
	<u>4,774,986</u>	<u>4,741,002</u>	<u>5,552,407</u>	<u>891,223</u>
Less: Carrying amount of bank loans that are not repayable within one year from the end of the reporting period but contain a repayment on demand clause (shown under current liabilities) .	(199,111)	(203,761)	(591,641)	(94,966)
Less: Amounts due within one year shown under current liabilities . . . . .	<u>(1,933,270)</u>	<u>(1,896,308)</u>	<u>(1,860,653)</u>	<u>(298,655)</u>
Total . . . . .	<u>2,642,605</u>	<u>2,640,933</u>	<u>3,100,113</u>	<u>497,602</u>

### 2010 Notes

On May 12, 2010, we issued an aggregate principal amount of US\$120 million of the 2010 Notes to finance property projects and for general corporate purposes. As of December 31, 2012, the entire principal amount of the 2010 Notes remains outstanding.

### 2012 Notes

On September 27, 2012, we issued an aggregate principal amount of US\$250 million of the 2012 Notes to fund our existing and new property projects, refinance our existing indebtedness and for general corporate purposes. As of December 31, 2012, the entire principal amount of the 2012 Notes remains outstanding.

### January 2013 Notes

On January 22, 2013 we issued an aggregate principal amount of US\$250 million of the January 2013 Notes to refinance our existing indebtedness, finance our existing and new project development projects and for other general corporate purposes.

### Commitments

As of December 31, 2012, our contractual obligations in connection with our property development activities, other than loans and borrowings, amounted to RMB4,811.2 million (US\$772.2 million), primarily arising from committed payment for land development expenditure and acquisition of subsidiaries. The following table sets forth our contractual obligations, other than loans and borrowings, as of the dates indicated:

	As of December 31,			
	2010	2011	2012	
	(RMB)	(RMB)	(RMB)	(US\$)
				(unaudited)
	(in thousands)			
Operating lease commitments:				
Within one year . . . . .	7,195	7,022	11,709	1,880
In the second to the fifth year inclusive . . . . .	20,037	18,428	34,703	5,570
After the fifth year . . . . .	10,190	5,638	3,310	531
	<u>37,422</u>	<u>31,088</u>	<u>49,722</u>	<u>7,981</u>

	As of December 31,			
	2010	2011	2012	
	(RMB)	(RMB)	(RMB)	(US\$)
	(unaudited)			
	(in thousands)			
Other commitments:				
Construction commitments in respect of properties for sale contracted for but not provided in the consolidated financial statements . . . . .	1,631,646	2,525,242	4,615,929	740,908
Land development expenditure commitments in respect of development cost contracted for but not provided in the consolidated financial statements. . .	–	98,202	91,130	14,627
Construction commitments in respect of investment properties contracted for but not provided in the consolidated financial statements . . . . .	50,366	206,353	47,192	7,575
Construction commitments in respect of hotels contracted for but not provided in the consolidated financial statements. . . . .	83,455	41,646	54,482	8,745
Consideration commitments in respect of acquisition of subsidiaries contracted for but not provided in the consolidated financial statements . . . . .	–	4,521	2,435	391
Commitment in respect of acquisition of land use rights contracted for but not provided in the consolidated financial statements . . . . .	140,000	–	–	–
	<u>1,905,467</u>	<u>2,875,964</u>	<u>4,811,168</u>	<u>772,246</u>

### Contingent Liabilities

As of December 31, 2012, we provided guarantees to PRC banks for loans with an aggregate principal amount of RMB2,750.8 million (US\$441.5 million), in respect of mortgages provided by the banks to purchasers of the properties we developed and sold. Our guarantees are issued from the dates of grant of the relevant mortgages and released upon issuance of property ownership certificates or after the full repayment of the underlying mortgages by the purchasers.

Pursuant to the terms of the guarantees, if there is default of the mortgage payments by purchasers of the properties, we are responsible to repay the outstanding mortgage loans, together with accrued interests thereon and any penalty owed by the purchasers in default to banks. We are entitled to take over the legal title of the related properties. The guarantee period commences from the date of grant of the relevant mortgage loan and ends after the relevant purchaser obtains the individual property ownership certificate. No provision for the guarantee contracts was recognized in the financial statement in 2012.

### Off-balance Sheet Commitments and Arrangements

Except for the contingent liabilities set forth above, we have not entered into any off-balance sheet guarantees or other commitments to guarantee the payment obligations of any third parties. We do not have any variable interest in any unconsolidated entity that provides financing, liquidity, market risk or credit support to us or engages in leasing or hedging or research and development services with us.

## **Market Risks**

We are exposed to various types of market risks, including changes in interest rate risks, foreign exchange risks and inflation risks in the normal course of business.

### ***Commodities Risk***

We are exposed to fluctuations in the prices of raw materials for our property developments, primarily steel and cement. We purchase most of our supplies of steel and cement at market prices. Such purchase costs are generally accounted for as part of contractors' fees pursuant to our arrangements with the relevant contractors. Rising prices for construction materials will therefore affect our construction costs in the form of increased fees payable to our contractors. As a result, fluctuations in the prices of our construction materials could have a significant impact on our results of operations.

### ***Interest Rate Risk***

Our business is sensitive to fluctuations in interest rates. Our indebtedness are typically fixed rate borrowings that are subject to negotiation in interest rate on an annual basis and any increase in interest rates will increase our finance costs. We currently do not hedge our interest rate risk, but may do so in the future.

An increase in interest rates may also adversely affect our prospective purchasers' ability to obtain financing and depress overall housing demand. Higher interest rates may adversely affect our revenue, gross profits and profits. The PBOC benchmark one-year lending rates in China (which directly affect the property mortgage rates offered by commercial banks in the PRC) as of December 31, 2010, 2011 and 2012 were 5.81%, 6.56% and 6.00%, respectively.

### ***Foreign Exchange Rate Risk***

We conduct our business exclusively in Renminbi. The value of Renminbi against the U.S. dollar and other currencies may fluctuate and is affected by, among other things, changes in China's political and economic conditions. The conversion of Renminbi into foreign currencies, including the U.S. dollar and the Hong Kong dollar, has been based on rates set by the PBOC. On July 21, 2005, the PRC government changed its decade-old policy of pegging the value of Renminbi to the U.S. dollar. Under the new policy, Renminbi is permitted to fluctuate within a narrow and managed band against a basket of certain foreign currencies. While the international reaction to the Renminbi revaluation has generally been positive, there remains significant international pressure on the PRC government to adopt an even more flexible currency policy, which could result in a further and more significant appreciation of Renminbi against the U.S. dollar. Fluctuations in the value of Renminbi to the U.S. dollar may adversely affect our cash flows, revenue, earnings and financial position. For example, if the value of Renminbi appreciates, we would record foreign exchange losses on bank balances and other assets we maintain in non-Renminbi currencies. Pending application of the net proceeds of this offering, we may invest the net proceeds from this offering in Temporary Cash Investments in U.S. dollars before they are used in our PRC operations. See "Risk Factors — Risks Relating to the PRC — Fluctuation in the exchange rates of the Renminbi may have a material adverse effect on your investment." We currently do not hedge our foreign exchange risk but may do so in the future.

### ***Inflation***

According to the National Bureau of Statistics of China, China's overall national inflation rate, as represented by the general consumer price index, was approximately 3.3%, 5.4% and 2.6% in the years ended December 31, 2010, 2011 and 2012, respectively. Deflation could negatively affect our business as it would be a disincentive for prospective property buyers to make a purchase.

## Non-GAAP Financial Measures

We use EBITDA to provide additional information about our operating performance. EBITDA refers to our earnings before the following items:

- fair value change of investment properties;
- recognition of change in fair value of completed properties for sales upon transfer to investment properties;
- impairment loss recognized in respect of goodwill;
- interest income/expense;
- amortization of intangible assets;
- non-operating income/expense;
- income tax expense; and
- depreciation.

EBITDA is not a standard measure under HKFRS. As the property development business is capital intensive, capital expenditure requirements and levels of debt and interest expenses may have a significant impact on the profit for the year of companies with similar operating results. Therefore, we believe the investor community commonly uses this type of financial measure to assess the operating performance of companies in our market sector.

As a measure of our operating performance, we believe that the most directly comparable HKFRS measure to EBITDA is profit for the year. We operate in a capital intensive industry. We use EBITDA in addition to profit for the year because profit for the year includes many accounting items associated with capital expenditures, such as depreciation, as well as non-operating items, such as amortization of intangible assets and interest income and interest expense. These accounting items may vary between companies depending on the method of accounting adopted by a company. By minimizing differences in capital expenditures and the associated depreciation expenses as well as reported tax positions, intangible assets amortization and interest income and expense, EBITDA provides further information about our operating performance and an additional measure for comparing our operating performance with other companies' results. Funds depicted by this measure may not be available for debt service due to covenant restrictions, capital expenditure requirements and other commitments.

The following table reconciles our profit for the year under HKFRS to our definition of EBITDA for the years indicated.

	For the year ended December 31,			
	2010	2011	2012	
	(RMB)	(RMB)	(RMB)	(US\$)
	(in thousands)			
	(unaudited)			
<b>Profit for the year</b> . . . . .	960,970	1,113,496	1,125,649	180,679
<b>Adjustments:</b>				
Gain on fair value changes of investment properties . . . .	(320,461)	(182,980)	(167,876)	(26,946)
Recognition of change in fair value of completed properties for sales upon transfer to investment properties . . . . .	(67,326)	(191,142)	(330,257)	(53,010)
Impairment loss recognized in respect of goodwill . . . . .	5,375	1,321	–	–
Finance cost – net . . . . .	160,757	98,993	47,274	7,588
<i>Interest expenses</i> . . . . .	180,131	108,471	57,698	9,261
<i>Interest income</i> . . . . .	(19,374)	(9,478)	(10,424)	(1,673)
Income tax expense . . . . .	828,708	1,038,344	1,261,209	202,438
Depreciation expenses . . . . .	11,058	21,474	37,478	6,016
Amortization expenses . . . . .	12,036	11,688	23,235	3,729
EBITDA . . . . .	1,591,117	1,911,194	1,996,712	320,494
EBITDA margin . . . . .	36%	34%	32%	32%

You should not consider our definition of EBITDA in isolation or construe it as an alternative to profit for the year or as an indicator of operating performance or any other standard measure under HKFRS. Our definition of EBITDA does not account for income taxes and other non-operating cash expenses. Our EBITDA measures may not be comparable to similarly titled measures used by other companies.

## INDUSTRY OVERVIEW

The information in the section below has been derived, in part, from official government sources unless otherwise indicated. This information has not been independently verified by us or the Initial Purchasers or any of our or their respective affiliates or advisors. The information may not be consistent with other information compiled within or outside the PRC.

### The Economy of China

#### Overview

The economy of China has grown significantly since the PRC government introduced economic reforms in the late 1970's. China's accession to the WTO in 2001 has further accelerated the reform of the PRC economy. China's nominal GDP has increased from approximately RMB21,631.4 billion in 2006 to approximately RMB51,932.2 billion in 2012 at a CAGR of approximately 15.7%.

The Chengdu-Chongqing Economic Zone, the Pearl River Delta region, the Yangtze River Delta region and the Beijing-Tianjin metropolitan region are four of the most economically prosperous and vibrant regions in China. The table below sets forth the GDP data for China and the aforementioned four regions for the years indicated:

	2006	2007	2008	2009	2010	2011	2012	06-12 CAGR
PRC . . . . .	21,631.4	26,581.0	31,404.5	34,090.3	40,151.3	47,310.4	51,932.2	15.7%
Chengdu-Chongqing Economic Zone . . . . .	624.2	744.7	899.8	1,103.3	1,347.7	1,686.6	1,959.8	21.0%
Pearl River Delta region . . . . .	2,158.9	2,560.6	2,972.6	3,214.7	3,767.3	4,372.1	4,784.7	14.2%
Yangtze River Delta region . . . . .	4,803.3	5,726.6	6,651.5	7,249.4	8,631.4	10,062.5	10,876.6	14.6%
Beijing-Tianjin metropolitan region . . . . .	1,247.7	1,489.7	1,746.9	1,967.5	2,333.8	2,755.9	3,068.6	16.2%

Sources: National Bureau of Statistics of China, Bureau of Statistics of respective cities

The table below sets forth the per capita disposable annual income for urban households for China and the aforementioned four regions for the years indicated. In 2012, China's per capita disposable income of urban households increased to approximately RMB24,565, an 12.6% increase compared to 2011.

	Per capita disposable income of urban households (in RMB)						
	2006	2007	2008	2009	2010	2011	2012
PRC . . . . .	11,759	13,786	15,781	17,175	19,109	21,810	24,565
Chengdu-Chongqing Economic Zone . . . . .	11,914	13,230	14,712	16,273	18,213	21,160	24,145
Pearl River Delta region . . . . .	20,990	23,026	22,677	24,842	27,536	29,686	N/A <sup>(1)</sup>
Yangtze River Delta region . . . . .	16,408	18,826	21,208	23,149	25,795	29,429	32,955
Beijing-Tianjin metropolitan region . . . . .	17,673	19,704	22,553	24,541	27,168	30,500	33,692

Sources: National Bureau of Statistics of China, Bureau of Statistics of respective cities

Note:

(1) Data not available.

## *Importance of Small- and Medium-Enterprises in the Economy of China*

Small and medium enterprises<sup>2</sup> are important pillars in the PRC economy. According to the 2011 Statistic Yearbook of Small and Medium Enterprises, in 2010, the number of employees in small- and medium-enterprises represents over 76% of the total employees of “above-scale enterprises”<sup>3</sup>, revenues from small- and medium-enterprises represent over 66% of the total revenues of above-scale enterprises; and gross output value of small- and medium-enterprises represents over 55% of such value of above-scale enterprises.

### **The Property Market In China**

#### *Overview*

We believe the economic growth of China, the increase in disposable income, the emergence of the mortgage lending market and the increase in the urbanization rate, are key factors in sustaining the growth of China’s property market. Government housing reforms continue to encourage private ownership and it is expected that an increasing proportion of urban residents who will own private properties will continue to increase over the coming years in the near future. The table below sets forth selected figures showing China’s urbanization rate and the increase in disposable income levels of the urban population in China for the periods indicated:

	2006	2007	2008	2009	2010	2011	2012
Urban population (in millions) . . . . .	582.9	606.3	624.0	645.1	669.8	690.8	711.8
Total population (in millions) . . . . .	1,314.5	1,321.3	1,328.0	1,334.5	1,340.9	1,347.4	1,354.0
Urbanization rate (%) . . . . .	44.3%	45.9%	47.0%	48.3%	49.9%	51.3%	52.6%
Annual disposable income of urban households (in RMB millions) . . . . .	6,854.3	8,358.8	9,847.7	11,079.7	12,799.1	15,066.0	17,485.7

Sources: National Bureau of Statistics of China, Bureau of Statistics of respective cities

Pearl River Delta region is the earliest area in China that has experienced real estate marketization. As China’s economy continues to develop and mature, there was an increasing shift in real estate activities from the southern part of China to the north. As a result, the Yangtze River Delta region and Beijing-Tianjin metropolitan region has joined the Pearl River Delta region to form three of the most prosperous zones in China. Due to various factors that include varying regional economic development level, city development characteristics and maturity of the different real estate markets, the property markets in the PRC possesses distinct regional differences. However, major cities in the three traditional economic zones of the Yangtze River Delta region, the Pearl River Delta region and the Beijing-Tianjin metropolitan region are still recognized as leading cities in the real estate market in China. The historical and recent development and trend in the real estate market in China has also shown an increase of activities from the eastern part of China to the west and from the coastal regions to the inland regions. Such trend, along with the implementation of the Western Development Policy by the PRC government to promote the development of China’s western region, the Chengdu-Chongqing Economic Zone has in recent years gradually attracted significant investment and has become the business hub of western China.

The table below sets forth the property development investment for China and the aforementioned four regions for the years indicated. China’s property development investment has increased from approximately RMB1,942.3 billion in 2006 to approximately RMB7,180.4 billion in 2012 at a CAGR of approximately 24.3%.

2. According to the Notice on Issuance of Provisions of Distinguish Standards for Small and Medium-Enterprises (關於印發中小企業劃型標準規定的通知) issued by the Ministry of Industry and Information Technology, NDRC, MOF and National Bureau of Statistics of China, small and medium-enterprises are defined based on the number of employees, revenues and the total assets value of such enterprises.
3. According to the section entitled “Description” in 2011 Statistic Yearbook of Small and Medium Enterprises, “above-scale enterprises” refers to all of the state-owned enterprises and the non-state-owned enterprises with annual revenue of over RMB5.0 million.



## Property Development Investment

	2006	2007	2008	2009	2010	2011	2012	06-12 CAGR
PRC . . . . .	1,942.3	2,528.9	3,120.3	3,624.2	4,825.9	6,179.7	7,180.4	24.3%
Chengdu-Chongqing								
Economic Zone . . . . .	124.3	175.5	191.5	218.4	289.9	361.1	439.8	23.4%
Pearl River Delta region . . . . .	166.4	226.4	256.6	258.3	311.9	402.3	N/A <sup>(1)</sup>	N/A <sup>(1)</sup>
Yangtze River Delta region . . . . .	474.9	564.4	643.1	705.6	931.3	1,186.0	1,381.4	19.5%
Beijing-Tianjin metropolitan region . .	212.2	250.1	256.2	307.3	376.8	411.6	441.3	13.0%

Sources: National Bureau of Statistics of China, Bureau of Statistics of respective cities

Note:

(1) Data not available.

### Property Price and Supply

The average price per square meter for the property market in China was approximately RMB5,791.0 in 2012, compared to approximately RMB3,366.8 in 2006. Supply of properties in China also increased from approximately 530.2 million square meters in 2006 to approximately 994.2 million square meters in 2012.

The table below sets forth selected data relating to the PRC property market for the years indicated:

	2006	2007	2008	2009	2010	2011	2012
Total GFA completed (in million square meters) . .	530.2	582.4	585.0	726.8	759.6	926.2	994.2
Total GFA sold (in million square meters) . . . . .	606.3	761.9	620.9	947.6	1,043.5	1,093.7	1,113.0
GFA of residential properties sold (in million square meters) . .	543.9	691.0	558.9	861.9	930.5	965.3	984.7
GFA of office buildings sold (in million square meters) . . . . .	12.3	14.7	11.6	15.4	18.9	20.0	22.5
Average price of properties (in RMB per square meter) . . . . .	3,366.8	3,863.9	3,800.0	4,681.0	5,032.0	5,357.1	5,791.0
Average price of residential properties (in RMB per square meter) .	3,119.3	3,645.2	3,576.0	4,459.0	4,725.0	4,993.2	5,429.9
Average price of office buildings (in RMB per square meter) . . . . .	8,052.8	8,667.0	8,378.0	10,608.0	11,406.0	12,327.3	12,302.6

Sources: National Bureau of Statistics of China, Bureau of Statistics of respective cities

## The Property Market in the Chengdu-Chongqing Economic Zone

The Chengdu-Chongqing Economic Zone centers around the cities of Chengdu and Chongqing and occupies an area of approximately 155,000 square meters. The region has a GDP of approximately RMB1,959.8 billion in 2012 and has a population of over 40 million. The Chinese government plans to construct various water conservancy facilities and energy supply system in the Chengdu-Chongqing Economic Zone and also plans to develop the region into a comprehensive transportation hub and logistics center. The Chengdu-Chongqing Economic Zone is an important base for China's advanced equipment manufacturing industry, modern service industry, high-tech industry and agriculture industry. The region is also a national pilot area for the co-ordination of urban and rural comprehensive reform and was classified as a national protected ecological security zone. The Chengdu-Chongqing Economic Zone serves as the primary success model as to western China's development potential.

Sale of properties in the Chengdu-Chongqing Economic Zone has experienced an upward trend in recent years. The total GFA of properties sold in the Chengdu-Chongqing Economic Zone increased from approximately 38.2 million square meters in 2006 to approximately 73.7 million square meters in 2012, representing a CAGR of approximately 11.6%. The table below sets forth selected data relating to the property market in the Chengdu-Chongqing Economic Zone for the years indicated:

	2006	2007	2008	2009	2010	2011	2012	06-12 CAGR
<b>Overview</b>								
Total GFA sold (in million square meters) . . . . .	38.2	57.8	43.3	67.1	68.7	72.5	73.7	11.6%
Total sales revenue (in RMB billions) . . . . .	108.6	191.9	150.9	271.2	336.6	395.7	437.0	26.1%
Average price of properties (in RMB per square meter) . . . . .	2,843	3,321	3,483	4,041	4,897	5,470	5,933	13.0%
Investment in properties (in RMB billions) . . . . .	124.3	175.5	191.5	218.4	289.9	361.1	439.8	23.4%

Sources: National Bureau of Statistics of China, Bureau of Statistics of respective cities

### Chengdu

Chengdu is the capital city of Sichuan Province and is located at the western edge of the Sichuan Basin, with an area of approximately 12,390 square kilometers. In 2007, the central government of the PRC designated Chengdu as a National Experimental Zone of Comprehensive Coordinated Reforms for Balanced Urban and Rural Development in recognition of Chengdu's comprehensive strength and development potential in western China. It had a population of approximately 14.2 million in 2012. Chengdu has experienced significant GDP growth rate in recent years from approximately RMB275.1 billion in 2006 to approximately RMB813.9 billion in 2012, representing a CAGR of approximately 19.8%, exceeding the CAGR of national GDP of approximately 15.7% over the same period.

In line with the rapid economic growth of Chengdu, the volume of sales of local properties has experienced an upward trend in recent years. According to the Chengdu Bureau of Statistics, the total GFA of properties sold in Chengdu increased from approximately 15.9 million square meters in 2006 to approximately 28.4 million square meters in 2012, representing a CAGR of approximately 10.2%. The average price of properties in Chengdu increased from approximately RMB3,646 per square meter in 2006 to approximately RMB7,288 per square meter in 2012, representing a CAGR of approximately 12.2%. Investment in properties in Chengdu in 2012 continued to show steady increase to approximately RMB188.9 billion. The table below sets forth data relating to the property market in Chengdu for the periods indicated:

	2006	2007	2008	2009	2010	2011	2012	06-12 CAGR
Total GFA sold (in million square meters) . . . . .	15.9	22.3	14.6	27.1	25.6	26.8	28.4	10.2%
Total sales revenue (in RMB billions) . . . . .	58.0	95.2	70.9	133.4	151.9	181.1	207.3	23.7%
Average price of properties (in RMB per square meter) . . . . .	3,646	4,276	4,857	4,925	5,937	6,717	7,288	12.2%
Investment in properties (in RMB billions) . . . . .	61.4	90.5	92.4	94.5	127.8	158.8	188.9	20.6%
Total GFA of office buildings sold (in thousand square meters) . . . . .	174.5	367.9	247.7	578.6	779.0	798.9	1,481.4	42.8%
Total sales revenue from office buildings (in RMB billions) . . . . .	0.81	2.15	1.68	3.40	7.23	8.05	13.64	59.9%
Average price of office buildings (in RMB per square meter) . . . . .	4,667	5,837	6,788	5,881	9,280	10,070	9,208	12.0%
Investment in office buildings (in RMB billions) . . . . .	1.24	1.83	2.22	3.09	5.05	8.34	N/A <sup>(1)</sup>	N/A <sup>(1)</sup>

Sources: National Bureau of Statistics of China, Chengdu Bureau of Statistics

Note:

(1) Data not available.

### The Property Market in the Pearl River Delta Region

The Pearl River Delta region is one of the leading economic regions and a major manufacturing center of China. It covers nine prefectures of the province of Guangdong, namely Guangzhou, Shenzhen, Zhuhai, Dongguan, Zhongshan, Foshan, Huizhou, Jiangmen and Zhaoqing, and is adjacent to Hong Kong and Macau. It had a population of over 56 million in 2012 and occupies an area of approximately 41,500 square meters. The Chinese government aims to make the Pearl River Delta region a shipping, logistics, trade, exhibition, tourism and innovation center for mutual development with Hong Kong and Macau, and position the region as a pioneer for carrying out various reforms and a key economic center of China.

Sale of properties in the Pearl River Delta region has experienced an upward trend in recent years. The total GFA of properties sold in the Pearl River Delta region increased from approximately 42.7 million square meters in 2006 to approximately 54.6 million square meters in 2011, representing a CAGR

of approximately 5.0%. The table below sets forth selected data relating to the property market in the Pearl River Delta region for the years indicated:

	<u>2006</u>	<u>2007</u>	<u>2008</u>	<u>2009</u>	<u>2010</u>	<u>2011</u>	<u>06-11</u> <u>CAGR</u>
<b>Overview</b>							
Total GFA sold (in million square meters) . . . . .	42.7	49.1	37.1	55.4	55.7	54.6	5.0%
Total sales revenue (in RMB billions) . . . . .	233.7	335.5	260.3	417.3	488.3	526.1	17.6%
Average price of properties (in RMB per square meter) . . . . .	5,473	6,836	7,014	7,530	8,763	9,635	12.0%
Investment in properties (in RMB billions) . . . . .	166.4	226.4	256.6	258.3	311.9	402.3	19.3%

Sources: National Bureau of Statistics of China, Bureau of Statistics of respective cities

Note: 2012 data not available.

### **Shenzhen**

Shenzhen is located in the southern part of Guangdong Province and borders Hong Kong with an area of approximately 1,953 square kilometers. It had a population of over 10.5 million in 2012. Shenzhen has experienced GDP growth in recent years from approximately RMB581.4 billion in 2006 to approximately RMB1,295.0 billion in 2012, representing a CAGR of approximately 14.3%. Shenzhen's GDP has ranked fourth in all cities in China from 2001 to 2006. Furthermore, in 2007, Shenzhen became the first and only city in China with a per capita GDP of over US\$10,000 according to various news reports.

In line with the economic growth of Shenzhen, property price has increased significantly in recent years. According to the Shenzhen Bureau of Statistics, the average price of properties increased from approximately RMB9,385 per square meters in 2006 to RMB19,590 per square meters in 2012, representing a CAGR of approximately 13.0%. The table below sets forth data relating to the property market in Shenzhen for the periods indicated:

	<u>2006</u>	<u>2007</u>	<u>2008</u>	<u>2009</u>	<u>2010</u>	<u>2011</u>	<u>2012</u>	<u>06-12</u> <u>CAGR</u>
Total GFA sold (in million square meters) . . . . .	7.5	5.6	4.7	7.6	4.7	5.0	5.3	(5.7%)
Total sales revenue (in RMB billions) . . . . .	70.3	78.0	59.1	111.4	89.3	108.5	103.0	6.6%
Average price of properties (in RMB per square meter) . . . . .	9,385	14,050	12,665	14,615	19,170	21,350	19,590	13.0%
Investment in properties (in RMB billions) . . . . .	46.2	46.1	44.0	43.7	45.8	51.5	73.7	8.1%

Sources: National Bureau of Statistics of China, Shenzhen Bureau of Statistics

## ***Dongguan***

Dongguan is a prefecture-level city located in central Guangdong province. It is an important industrial city located in the Pearl River Delta region and borders the provincial capital of Guangzhou with an area of approximately 2,465 square kilometers. It had a population of approximately 8.3 million in 2012. Dongguan has experienced significant GDP growth in recent years from approximately RMB262.7 billion in 2006 to approximately RMB501.0 billion in 2012, representing a CAGR of approximately 11.4%.

In line with the economic growth of Dongguan, the volume of sales of local properties has experienced an upward trend in recent years. According to the Dongguan Bureau of Statistics, the total GFA of properties sold in Dongguan increased from approximately 3.8 million square meters in 2006 to approximately 6.0 million square meters in 2011, representing a CAGR of approximately 9.3%. The table below sets forth data relating to the property market in Dongguan for the years indicated:

	<u>2006</u>	<u>2007</u>	<u>2008</u>	<u>2009</u>	<u>2010</u>	<u>2011</u>	<u>06-11 CAGR</u>
Total GFA sold (in million square meters) . . . . .	3.8	5.7	5.1	6.0	5.1	6.0	9.3%
Total sales revenue (in RMB billions) . . . . .	16.1	29.5	28.4	35.3	37.4	46.0	23.3%
Average price of properties (in RMB per square meter) . . . . .	4,221	5,148	5,567	5,881	7,310	7,717	12.8%
Investment in properties (in RMB billions) . . . . .	16.4	20.9	27.1	27.8	29.9	37.3	17.8%

*Sources:* National Bureau of Statistics of China, Dongguan Bureau of Statistics

*Note:* 2012 data not available.

## ***Huizhou***

Huizhou is a prefecture-level city located in the south-eastern part of Guangdong Province with an area of approximately 11,200 square kilometers. It had a population of approximately 4.6 million in 2012. Huizhou has experienced GDP growth rate in recent years from approximately RMB93.5 billion in 2006 to approximately RMB236.8 billion in 2012, representing a CAGR of approximately 16.8%.

In line with the economic growth of Huizhou, the volume of sales of local properties has experienced an upward trend in recent years. According to the Huizhou Bureau of Statistics, the total GFA of properties sold in Huizhou increased from approximately 2.5 million square meters in 2006 to approximately 8.0 million square meters in 2011, representing a CAGR of approximately 25.7%. The table below sets forth data relating to the property market in Huizhou for the years indicated:

	<u>2006</u>	<u>2007</u>	<u>2008</u>	<u>2009</u>	<u>2010</u>	<u>2011</u>	<u>06-11 CAGR</u>
Total GFA sold (in million square meters) . . . . .	2.5	3.9	3.0	5.4	6.3	8.0	25.7%
Total sales revenue (in RMB billions) . . . . .	7.6	15.6	12.2	23.2	31.1	44.2	42.3%
Average price of properties (in RMB per square meter) . . . . .	2,976	3,995	4,121	4,266	4,960	5,535	13.2%
Investment in properties (in RMB billions) . . . . .	6.9	13.8	18.7	17.5	26.8	37.8	40.5%

*Sources:* National Bureau of Statistics of China, Huizhou Bureau of Statistics

*Note:* 2012 data not available.

## The Property Market in the Yangtze River Delta Region

The Yangtze River Delta region has one of the strongest regional economies in China. It includes two provinces, Jiangsu and Zhejiang, and one city, Shanghai. Its population accounts for approximately 11.6% of China's total population and its GDP accounts for approximately 20.9% of China's total GDP. The Chinese government has positioned the Yangtze River Delta region as China's strongest economic, financial, trading and shipping centers.

Sale of properties in the Yangtze River Delta region has experienced an upward trend in recent years. The total GFA of properties sold in the Yangtze River Delta region increased from approximately 126.7 million square meters in 2006 to approximately 149.2 million square meters in 2012, representing a CAGR of approximately 2.8%. The table below sets forth selected data relating to the property market in the Yangtze River Delta Region for the years indicated:

	2006	2007	2008	2009	2010	2011	2012	06-12 CAGR
Total GFA sold								
(in million square meters) . . . . .	126.7	158.4	107.0	191.6	163.6	132.9	149.2	2.8%
Total sales revenue (in RMB billions) .	606.1	877.5	623.6	1,377.1	1,298.0	1,131.4	1,299.9	13.6%
Average price of properties								
(in RMB per square meter) . . . . .	4,783	5,542	5,557	7,188	7,933	8,511	8,711	10.5%
Investment in properties								
(in RMB billions) . . . . .	474.9	564.4	643.1	705.6	931.3	1,186.0	1,381.4	19.5%

Sources: National Bureau of Statistics of China, Bureau of Statistics of respective cities

### Yixing

Yixing is a county-level city in Wuxi, Jiangsu Province, with an area of approximately 2,177 square kilometers. It had a population of approximately 1.1 million in 2012. Yixing has experienced significant GDP growth in recent years from approximately RMB42.8 billion in 2006 to approximately RMB98.0 billion in 2011, representing a CAGR of approximately 18.0% and exceeding the CAGR of national GDP of approximately 16.8% over the same period.

In line with the economic growth of Yixing, the volume of sales of local properties has experienced an upward trend in recent years. According to the Yixing Bureau of Statistics, the total sales revenue of properties sold in Yixing increased from approximately 3.8 billion in 2006 to approximately 7.9 billion in 2011, representing a CAGR of approximately 15.7%. The table below sets forth data relating to the property market in Yixing for the periods indicated:

	2006	2007	2008	2009	2010	2011	2012	06-12 CAGR
<b>Yixing</b>								
Total GFA sold								
(in million square meters) . . . . .	1.3	1.7	0.7	1.1	1.1	0.9	1.4	0.2%
Total sales revenue (in RMB billions) .	3.8	5.4	2.3	6.2	7.5	7.9	N/A <sup>(1)</sup>	N/A <sup>(1)</sup>
Average price of properties								
(in RMB per square meter) . . . . .	2,919	3,417	3,226	5,500	6,968	9,082	N/A <sup>(1)</sup>	N/A <sup>(1)</sup>
Investment in properties								
(in RMB billions) . . . . .	3.4	3.6	3.8	3.6	5.4	8.0	10.8	21.4%

Sources: National Bureau of Statistics of China, Yixing Bureau of Statistics

Note:

(1) Data not available.

## The Property Market in the Beijing-Tianjin Metropolitan Region

Beijing-Tianjin metropolitan region centers around two cities, Beijing and Tianjin, which are the most economically vibrant cities in northern China. In 2012, the region had a GDP of RMB3,068.6 billion and accounted for approximately 5.9% of China's total GDP.

Sale of properties in the Beijing-Tianjin metropolitan region has experienced an upward trend in recent years. The average price of properties increased from approximately RMB7,022 per square meter in 2006 to approximately RMB12,964 per square meter in 2012, representing a CAGR of approximately 10.8%. The table below sets forth selected data relating to the property market in the Beijing-Tianjin metropolitan region for the years indicated:

	2006	2007	2008	2009	2010	2011	2012	06-12 CAGR
Total GFA sold (in million square meters) . . . . .	40.7	37.3	25.9	39.5	32.0	30.3	36.1	(2.0%)
Total sales revenue (in RMB billions) .	285.5	341.5	241.1	435.5	416.2	382.0	467.4	8.6%
Average price of properties (in RMB per square meter) . . . . .	7,022	9,166	9,320	11,018	12,989	12,591	12,964	10.8%
Investment in properties (in RMB billions) . . . . .	212.2	250.1	256.2	307.3	376.8	411.6	441.3	13.0%

Sources: National Bureau of Statistics of China, Bureau of Statistics of respective cities

### Tianjin

Tianjin is one of the four municipalities of China that are directly under the central government and have provincial-level status, with an area of approximately 11,920 square kilometers. It had a population of approximately 14.1 million in 2012. The city's urban area is located along the Haihe River and its ports are located on Bohai Gulf in the Pacific Ocean. Tianjin has experienced significant GDP growth in recent years from approximately RMB435.9 billion in 2006 to approximately RMB1,288.5 billion in 2012, representing a CAGR of approximately 19.8% and exceeding the CAGR of national GDP of approximately 15.7% over the same period.

In line with the economic growth of Tianjin, the volume of sales of local properties has experienced an upward trend in recent years. According to the Tianjin Bureau of Statistics, the total GFA of properties sold in Tianjin increased from approximately 14.6 million square meters in 2006 to approximately 16.6 million square meters in 2012, representing a CAGR of approximately 2.2%. The average price of properties in Tianjin increased from approximately RMB4,774 per square meter in 2006 to approximately

RMB8,218 per square meter in 2012, representing a CAGR of approximately 9.5%. The table below sets forth selected data relating to the property market in Tianjin for the years indicated:

	2006	2007	2008	2009	2010	2011	2012	06-12 CAGR
Total GFA sold (in million square meters) . . . . .	14.6	15.5	12.5	15.9	15.1	15.9	16.6	2.2%
Total sales revenue (in RMB billions) . . . . .	69.6	90.0	75.3	109.5	124.6	139.4	136.6	11.9%
Average price of properties (in RMB per square meter) . . . . .	4,774	5,811	6,015	6,886	8,197	8,745	8,218	9.5%
Investment in properties (in RMB billions) . . . . .	40.2	50.5	65.4	73.5	86.7	108.0	126.0	21.0%
Total GFA of office buildings sold (in thousand square meters) . . . . .	370.8	429.5	293.0	295.5	352.9	428.0	281.7	(4.5%)
Total sales revenue from office buildings (in RMB billions) . . . . .	2.29	3.18	2.87	3.29	4.89	5.35	3.76	8.6%
Average price of office buildings (in RMB per square meter) . . . . .	6,171	7,412	9,783	11,134	13,855	12,510	13,349	13.7%
Investment in office buildings (in RMB billions) . . . . .	2.37	3.45	3.10	3.28	7.72	10.98	N/A <sup>(1)</sup>	N/A <sup>(1)</sup>

Sources: National Bureau of Statistics of China, Tianjin Bureau of Statistics

Note:

(1) Data not available.

## The Property Management Industry In China

Against the backdrop of the development of the underlying property market and the improvement in living standards as a result of rapid economic growth, there has been a growing demand for property management services in China in recent years. However, the industry remains at an early stage of development, characterized by an industry structure that is highly fragmented with a large number of relatively small participants operating in a competitive environment. According to the Survey Report on Property Management Industry (物業管理行業生存狀況調查報告) issued by the China Property Management Association (中國物業管理協會) in December 2009, of the 4,600 property management companies in China that participated in the survey, approximately 5.8% were established between 1981 to 1994, approximately 76.0% were established between 1994 to 2004, and approximately 18.2% were established between 2004 to 2007.

Our directors are optimistic that, while competition is intense, the long-term growth prospects for the property management industry in China are promising as the underlying property market continues to develop along with China's economic growth. Our directors also expect that, as the industry continues to develop, there will be a growing demand for quality and reliable services from property management companies with industry consolidation that eliminates small and inefficient companies and allowing companies with sufficient resources operating on economies of scale to eventually emerge as market leaders.



## **The Hotel Services Industry In China**

The growth of the PRC economy and its tourism industry has led to a rapid development of the hotel industry in China in recent years. According to the National Bureau of Statistics of China and the National Tourism Administration of China (中國國家旅遊局), total tourism volume grew from 1,519 million visits in 2006 to 3,092 million visits in 2012 with a CAGR of 12.6% and total tourism revenue in China grew from RMB894 billion in 2006 to RMB2,244 billion in 2011 with a CAGR of 20.2%. As a result of the desire to benefit from an increasingly affluent domestic population as well as the influx of visitors, many foreign corporate and hotel investors, developers and operators have entered into the hotel industry in China with a hope of securing a presence in the industry. In addition, China's entry into the WTO in 2002, Beijing's successful organization of the 2008 Olympic games and Shanghai's successful organization of the World Expo in 2010, have served to illustrate China's importance in the world stage, and thereby furthered strong interest and growth in the hotel industry in China, especially in the major cities.

# CORPORATE STRUCTURE

The following chart shows our corporate structure as of the date of this offering memorandum:

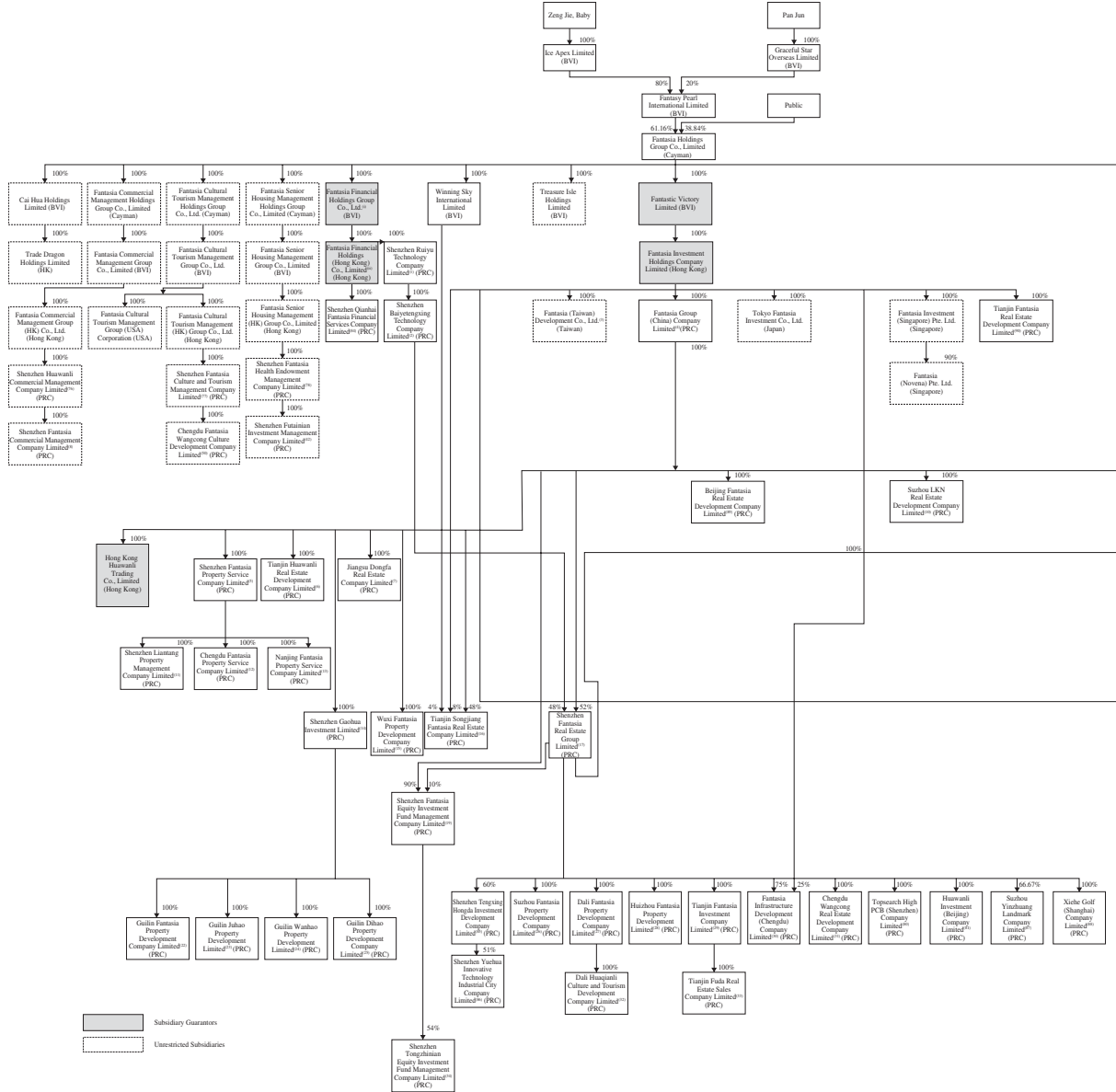

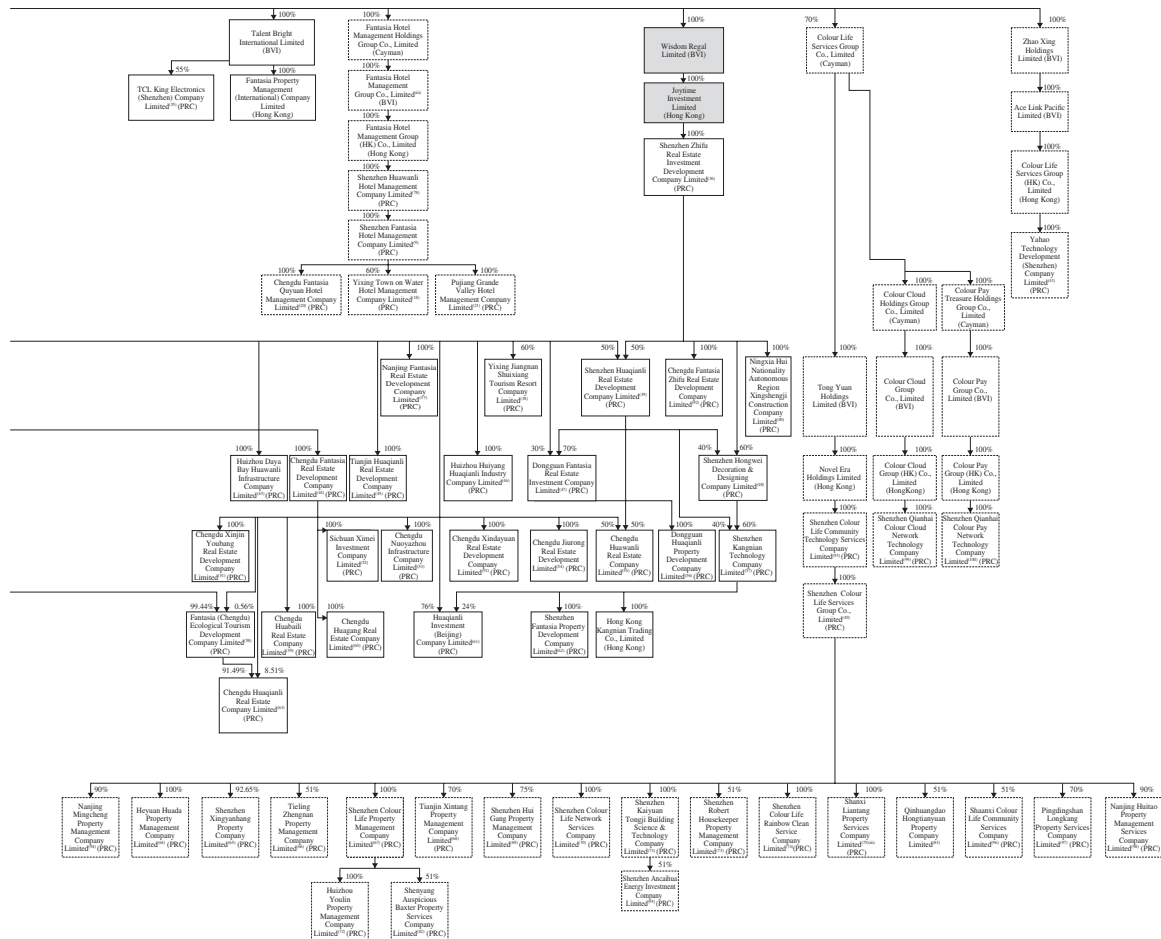

**Notes:**

- (i) previously known as *Strong Nova Holdings Limited*
- (ii) previously known as *Splendor Sun Holdings Limited*
- (iii) previously known as *Shanxi Zhongqiang Property Management Company Limited (陝西中強物業管理有限公司)*

*The Chinese names of the Taiwan and PRC entities are as follows:*

- (1) 深圳市瑞禹科技有限公司
- (2) 深圳市百業騰興科技有限公司
- (3) 臺灣花樣年開發股份有限公司
- (4) 花樣年集團(中國)有限公司
- (5) 深圳市花樣年物業服務有限公司
- (6) 天津市花萬里房地產開發有限公司
- (7) 江蘇東發置業有限公司
- (8) 深圳花樣年商業管理有限公司
- (9) 深圳市花樣年酒店管理有限公司
- (10) 蘇州林甲岩房產發展有限公司
- (11) 深圳市蓮塘物業管理有限公司
- (12) 成都市花樣年物業服務有限公司
- (13) 南京花樣年物業服務有限公司
- (14) 深圳市高華投資有限公司
- (15) 無錫花樣年房地產開發有限公司
- (16) 天津松江花樣年置業有限公司
- (17) 深圳市花樣年地產集團有限公司
- (18) 宜興市雲海間酒店管理有限公司
- (19) 深圳市花樣年股權投資基金管理有限公司
- (20) 成都花樣年趣園酒店管理有限公司
- (21) 蒲江縣大溪谷酒店管理有限公司
- (22) 桂林市花樣年房地產開發有限公司
- (23) 桂林聚豪房地產開發有限公司
- (24) 桂林萬豪房地產開發有限公司
- (25) 桂林帝豪房地產開發有限公司
- (26) 蘇州市花樣年房地產開發有限公司
- (27) 大理市花樣年房地產開發有限公司
- (28) 惠州市花樣年房地產開發有限公司
- (29) 天津市花樣年投資有限公司
- (30) 花樣年實業發展(成都)有限公司
- (31) 成都望叢房地產開發有限公司
- (32) 大理市花千里文化旅遊開發有限公司
- (33) 天津福大房地產銷售有限公司
- (34) 深圳市同之年股權投資基金管理有限公司
- (35) TCL王牌電子(深圳)有限公司
- (36) 深圳置富房地產開發有限公司
- (37) 南京花樣年房地產開發有限公司
- (38) 宜興市江南水鄉度假村有限公司
- (39) 深圳市花千里房地產開發有限公司
- (40) 寧夏回族自治區新聖基建築工程有限公司
- (41) 雅浩科技發展(深圳)有限公司
- (42) 深圳市福泰年投資管理有限公司
- (43) 惠州大亞灣花萬里實業有限公司
- (44) 成都市花樣年房地產開發有限公司
- (45) 天津市花千里房地產開發有限公司
- (46) 惠州市惠陽區花千里實業有限公司
- (47) 東莞市花樣年房地產投資有限公司
- (48) 深圳宏威裝飾設計工程有限公司
- (49) 深圳市彩生活服務集團有限公司
- (50) 成都花樣年望叢文化發展有限公司
- (51) 成都新津友幫房地產開發有限責任公司
- (52) 四川西美投資有限公司
- (53) 成都市諾亞舟實業有限公司
- (54) 成都九蓉房地產開發有限公司
- (55) 成都花萬里置業有限公司
- (56) 東莞市花千里房地產開發有限公司
- (57) 深圳市康年科技有限公司
- (58) 花樣年(成都)生態旅遊開發有限公司
- (59) 成都花百里置業有限公司
- (60) 成都花港置業有限公司
- (61) 花千里投資(北京)有限公司
- (62) 深圳市花樣年房地產開發有限公司
- (63) 成都花千里置業有限公司
- (64) 河源市華達物業管理有限公司
- (65) 深圳市星彥行置業有限公司
- (66) 鐵嶺正南物業管理有限公司
- (67) 深圳市彩生活物業管理有限公司
- (68) 天津新塘物業管理有限公司
- (69) 深圳市匯港物業管理有限責任公司
- (70) 深圳市花樣年彩生活網絡服務有限公司
- (71) 深圳市開元同濟樓宇科技有限公司
- (72) 惠州市友鄰物業管理有限公司
- (73) 深圳市羅伯特管家物業管理有限公司
- (74) 深圳市彩生活彩虹清潔服務有限公司
- (75) 陝西蓮塘物業服務有限公司
- (76) 深圳市花萬里商業管理有限公司
- (77) 深圳市花樣年文化旅遊管理有限公司
- (78) 深圳市花樣年養生養老管理有限公司
- (79) 深圳市花萬里酒店管理有限公司
- (80) 至卓飛高線路板(深圳)有限公司
- (81) 花萬里投資(北京)有限公司
- (82) 瀋陽吉祥百特物業服務有限公司
- (83) 秦皇島市宏添源物業服務有限公司

- (84) 深圳市前海花樣年金融服務有限公司
- (85) 深圳市騰星宏達投資發展有限公司
- (86) 深圳市越華創新科技工業城有限公司
- (87) 蘇州銀莊置地有限公司
- (88) 協和高爾夫(上海)有限公司
- (89) 北京花樣年房地產開發有限公司
- (90) 天津花樣年房地產開發有限公司
- (91) 成都新達遠房地產開發有限公司
- (92) 成都花樣年置富房地產開發有限公司
- (93) 深圳市彩生活社區科技服務有限公司
- (94) 南京名城物業管理有限公司
- (95) 深圳市安彩華能源投資有限公司
- (96) 陝西彩生活社區服務有限公司
- (97) 平頂山市隆康物業服務有限公司
- (98) 南京市慧韜物業管理服務有限公司
- (99) 深圳市前海彩之雲網絡科技有限公司
- (100) 深圳市前海彩付寶網絡技術有限公司

## BUSINESS

### Overview

We are a leading property developer and property related service provider in China. For four consecutive years from 2009 to 2012, we have members of our Group ranked among the China Top 100 Real Estate Developers (中國房地產百強企業) and the China Top 100 Property Management Companies (中國物業服務百強企業) by the China Real Estate Top 10 Research Team (中國房地產Top 10研究組). We were also ranked among the China Real Estate Top 100 Listed Companies (中國房地產上市公司百強) in 2011 and the Top 50 China Real Estate Listed Companies in terms of Comprehensive Strength (中國房地產上市公司綜合實力五十強) in 2011 and 2012 by the China Real Estate Research Institute, China Real Estate Association and China Real Estate Assessment Center. We first commenced our property development business in Shenzhen in 1996. Leveraging on our broad experience and capabilities, we have successfully expanded into, and currently focus our real estate activities in, four of the fastest-growing economic regions in China, including the Chengdu-Chongqing Economic Zone, the Pearl River Delta region, the Yangtze River Delta region and the Beijing-Tianjin metropolitan region.

Our target customers are affluent middle- to upper-class individuals and families and fast growing small- to medium-sized enterprises. We envisage that the demand for properties designed for these customers will increase as such customers' household income and purchasing power continue to rise. To cater to the diverse needs of our target customers, we have developed a portfolio of property development projects with a focus on the following:

- *Urban Complexes*

Our urban complexes are mostly located in the peripheral areas of existing central business districts in major cities such as Shenzhen and Chengdu or in the emerging new business districts designated under city development plans of local governments. These complexes integrate various types of properties, such as offices, apartments, retail shops and/or boutique hotels, into a single property development project. For example, our urban complex Chengdu Hailun Plaza (成都喜年廣場), which has received several awards, is one of the tallest buildings and a local landmark in Chengdu, and we believe our Chengdu MIC Plaza (formerly known as Chengdu Meinian International Plaza, 成都美年國際廣場) is one of the largest urban complexes currently under development in Chengdu.

- *Boutique Upscale Residences*

Our boutique upscale residences are located in urban and suburban areas with natural scenic surroundings or cultural landmarks. They are connected by roads or expressways to the centers of major metropolitan areas. These boutique upscale residences include high- and low-rise apartment buildings, townhouses and stand-alone houses and cater to the residential and investment needs of our high-end consumers. We typically develop our boutique upscale residential projects in several phases so that we can manage our capital resources more efficiently and increase the average selling price as the project becomes more developed and attractive to our customers. Examples of such boutique upscale residential projects include Grand Valley (大溪谷), a large scale residential complex in Pujiang County of Chengdu that is surrounded by natural sceneries, and Chengdu Belle Epoque (成都君山), a large scale residential community located in a famous tourist attraction in Xinjin County of Chengdu, Yixing Town on the Water (雲海閣), adjacent to the Hengshan Reservoir in Jiangsu province, and Dongguan Mont Conquerant (東莞君山), adjacent to the Fengjing Golf Course.

As of December 31, 2012, our portfolio of land bank consisted of approximately 31% of boutique upscale residences, 36% of urban complexes and 33% of mid-to-high end residences in terms of GFA. We plan to continue to focus our property development activities on developing a portfolio of products that caters to our target customers across four of China's most economically prosperous regions. We plan to achieve this objective by continuing to selectively acquire low-cost land in the four regions. We conduct comprehensive and in-depth market research and analysis on the land that we intend to acquire and the

surrounding areas. We consider the geographic as well as marketing factors when evaluating a target parcel, including development potentials, size and suitability of the land for developments that can fit into our existing portfolio, convenience and availability of infrastructure support, purchasing power of our potential customers in relevant areas, development costs and the estimated return on investment. We budget for the cost of land acquisition as well as the overall development costs, which are subject to strict internal procedures and are closely monitored and adjusted throughout the construction process. Acquisition proposal is reviewed and approved by the relevant personnel of our Group, including our chief executive officer and our board of directors. We usually acquire land using our own capital within a pre-set budget and arrange project loans with banks in China at a later stage to support the subsequent development of the property.

In addition to our property development business, we also provide property operation services, property agency services and hotel services to our own properties and properties of third parties. In February 2011, we disposed of our entire 85% equity interests in Shenzhen Xingyan Property Consultancy Company Limited (深圳市星彥地產顧問有限公司), our subsidiary engaged in the provision of property agency services, to concentrate on our main business, but we still maintain secondary property brokerage services as a value-added service in the property operation services business. We believe our property related services enable us to strengthen our property development capabilities. For example, our property operation services enhance the value of our properties. We plan to continue to enhance such real estate services that we offer and to further enhance the intrinsic synergies between our real estate products and services. We will in particular focus on enhancing our property operation services and hotel services which we believe will serve as relatively stable and growing revenue sources to our Group on one hand, and will continue to increase the attractiveness and the average selling price of the properties developed by us on the other.

We have received numerous accolades for our property development and services capabilities. For example, our subsidiary, Fantasia (Chengdu) Development Co., Ltd. was awarded one of the real estate industry's highest honorary award "Golden Tripod" — 2009 outstanding development Business Awards ("金鼎獎" — 2009年度優秀開發企業獎) jointly issued by Chengdu Municipal Government (成都市政府) and the Chengdu Real Estate Bureau (成都房地產管理局) in 2010. Another subsidiary, Shenzhen Color Life Services Group Company Limited, was awarded "Top 10 Growth Enterprises in Top 100 Property Services Companies in China in 2012" (2012中國物業服務百強企業成長性TOP 10) and "China Top 100 Property Services Companies" (中國物業服務百強企業) for four consecutive years from 2009 to 2012 by China Real Estate Top 10 Research Team (中國房地產TOP 10研究組) in June 2012. Our subsidiary, Shenzhen Color Life Services Group Company Limited was awarded "2012 China Property Services Enterprise of Brand Excellence" (2012中國物業服務優秀品牌企業) by China Index Research Institute in August 2012. We were also awarded "2012 China Best Commercial Real Estate Brand" (2012中國最佳商業地產品牌) by Organizing Committee of Boao Real Estate Forum (博鰲房地產論壇委員會) in August 2012, and was listed on both "List of Top 100 Outstanding Real Estate Enterprises in China for 2012" (2012年度中國房地產卓越100榜) and "List of China's Outstanding Real Estate Management and Real Estate Teams in China for 2012" (2012年度中國房地產管理與團隊卓越榜) by *guan dian.cn* (觀點地產新媒體). Our property development projects have also won numerous awards and recognitions for their design and quality. For example, our project Shenzhen Meinian International Complex (深圳美年國際廣場) was awarded "China Real Estate Index System: The Best Business Complex of Garden Style in South China in 2010" (2010 中國房地產指數系統華南最佳園林式商務綜合體) by China Real Estate Association (中國房地產協會) and China Index Research Institute (中國指數研究院) in 2010. Tianjin Hailun Plaza (天津喜年廣場) was awarded "Structural HaiHe Cup" (結構海河杯) by Tianjin Construction Association (天津市建築業協會) in 2010. Dongguan Mont Conquerant (東莞君山) was awarded "China Real Estate Index System: Top Ten Distinctive Villa Models in 2010 — Villa in the Air" (2010中國房地產指數系統十大特色典範別墅—空中別墅) by China Index Research Institute (中國指數研究院) in 2010. Chengdu Hailun Plaza (成都喜年廣場) was awarded "2010 – 2011 Silver Medal of the State Outstanding Construction Projects" (2010年–2011年度國家優質工程銀獎) organized by China Construction Industry Association (中國建築業協會) in 2011. Guilin Fantasia Town was awarded "Real Estate with the Most Potential in Value in 2011" (2011年最具價值潛力樓盤) by the Fourth Session of Guilin Spring Brand Real Estate Fair (桂林第四屆春季品牌房地產交易會) in 2011. Shenzhen Funian Plaza was awarded "Grand Prize for Commercial Real Estate for 2012" (2012年度商業地產大獎) by 21st Century Business Herald (《21世紀經濟報導》) and Golden Brick Award Selection Committee for Real Estate of China (中國地產金磚獎評選委員會) in July 2012. It was further awarded "Grand Prize of

Office Building of the Year at the 2012 China's Real Estate Annual Meeting" (2012中國地產年會年度寫字樓大獎) by Nanfang City News (《南方都市報》). Nanjing Yuhuatai Project was awarded "The Best Commercial Real Estate in Nanjing, China for 2012" (2012中國(南京)最佳商業地產) by Yangtze Evening News (《揚子晚報》).

As of December 31, 2012, we had a total of 40 projects at various stages of development (including completed projects, projects under development and projects held for future development), including 14 projects located in the Chengdu-Chongqing Economic Zone, 13 projects located in the Pearl River Delta region, eight projects located in the Yangtze River Delta region and five projects located in the Beijing-Tianjin metropolitan region.

As of December 31, 2012, we had a total land bank of approximately 11,714,530 square meters, which consists of:

- an aggregate planned GFA of approximately 8,025,896 square meters of properties for which we had fully paid the land premium and obtained land use rights (consisting of an aggregate planned GFA of approximately 2,672,213 square meters of properties under development and an aggregate planned GFA of approximately 5,353,683 square meters of properties held for future development for which we have obtained land use rights); and
- an aggregate planned GFA of approximately 3,688,634 square meters of properties for which we had entered into preliminary framework agreements but had not obtained the land use rights or property rights.

Of our total land bank as of December 31, 2012, approximately 6,645,173 square meters, or 56.7%, were located in the Chengdu-Chongqing Economic Zone; approximately 3,317,137 square meters, or 28.3%, were located in the Pearl River Delta region; approximately 901,562 square meters, or 7.7%, were located in the Yangtze River Delta region; and approximately 850,658 square meters, or 7.3%, were located in the Beijing-Tianjin metropolitan region. We develop most of our properties, including properties that are currently under development, for sale but will hold certain of these developed properties for investment and hotel management purposes.

For each of the years ended December 31, 2010, 2011 and 2012, our revenue was RMB4,471.2 million, RMB5,592.4 million and RMB6,230.1 million (US\$1,000.0 million), respectively. Our revenue for the three years ended December 31, 2010, 2011 and 2012 consisted of revenue derived from (i) the sales of our developed properties, (ii) the lease of investment properties, (iii) the provision of property agency and related services, (iv) the provision of property operation and related services, and (v) the provision of hotel management and related services. The following table sets forth our revenue for each of the components described above and the percentage of total revenue represented for the years indicated with the fluctuations of the percentage due primarily to the different product mix delivered to customers in respective period:

	For the year ended December 31,						
	2010		2011		2012		
	(RMB)	(%)	(RMB)	(%)	(RMB)	(US\$)	(%)
	(unaudited)						
	(in thousands, except percentages)						
Property development . . . . .	4,320,413	96.6	5,396,289	96.5	5,885,314	944,658	94.5
Property investment . . . . .	17,727	0.4	37,887	0.7	90,266	14,489	1.4
Property agency services . . . . .	36,845	0.8	10,571	0.2	14,470	2,322	0.2
Property operation services . . . . .	89,228	2.0	124,895	2.2	184,683	29,644	3.0
Hotel services . . . . .	7,021	0.2	22,708	0.4	55,317	8,879	0.9
Total . . . . .	4,471,234	100.0	5,592,350	100.0	6,230,050	999,992	100.0



## Recent Developments

Subsequent to December 31, 2012, we entered into certain framework agreements and formal agreements in relation to acquisition of parcels of land as set forth in the table below:

Date of framework agreement/ Time of Acquisition	Location	Attributable interest	Site area (square meters)	Planned total GFA (square meters)	Consideration (RMB in millions)	Type
February 2013 . . . . .	Wenjiang, Chengdu	100%	73,394	293,588	213.00	Residential and commercial
February 2013 . . . . .	Shenzhen	100%	43,236	117,000	95.80	Industrial offices
March 2013 . . . . .	Suzhou	100%	73,059	199,865	511.00	Residential and commercial
March 2013 . . . . .	Singapore	90%	13,023	14,500	754.00	Residential
March 2013 . . . . .	Dongguan	100%	14,306	33,719	31.50	Residential
April 2013 . . . . .	Pixian, Chengdu	100%	40,381	175,249	199.88	Residential and commercial
May 2013 . . . . .	Shanghai	100%	N/A	17,563	282.50	Residential
Total . . . . .			<u>257,399</u>	<u>851,484</u>	<u>2,087.68</u>	

## Our Competitive Strengths

### *Property development portfolio strategically located across four of China's most economically prosperous regions*

We focus our business activities across four of the most economically prosperous and vibrant regions in China, namely, the Chengdu-Chongqing Economic Zone, the Pearl River Delta region, the Yangtze River Delta region and the Beijing-Tianjin metropolitan region. Each of the four regions has experienced relatively strong growth over the past few years. As of December 31, 2012, our planned GFA under development and held for future development in each of the Chengdu-Chongqing Economic Zone, the Pearl River Delta region, the Yangtze River Delta region and the Beijing-Tianjin metropolitan region was approximately 3,105,325 square meters, 3,217,597 square meters, 852,316 square meters and 850,658 square meters, respectively. We have already established a strong market position in certain of our targeted regions, such as in the Chengdu-Chongqing Economic Zone and the Pearl River Delta region, and several of our developments in those regions received various awards. During 2010, 2011 and 2012, we completed a total of three, two and three projects or phases of projects with an aggregate GFA of approximately 366,073, 338,983 and 438,004 square meters, respectively, in Chengdu, and a total of three, three and one projects or phases of projects with an aggregate GFA of approximately 99,319, 258,204 and 61,156 square meters, respectively, in Shenzhen. We believe that a significant portion of our target customers operate and reside in these four regions, and our location and presence in these regions have enabled us to capture the growing demand of our target customers.

### *Ability to acquire land at low cost*

For the year ended December 31, 2012, our average unit land cost based on GFA was approximately 10.59% of our average unit selling price. We focus on developing urban complexes in the peripheral areas of existing central business districts or emerging new business districts and boutique upscale residences in the urban and suburban areas. As a result, we have a wide range of choices when selecting land sites for our property developments than other property developers who focus on developing properties in existing central business districts or well-established residential areas in major cities. We believe our wide range of choices of land sites allows us to avoid intense competition in the land acquisition process and thereby reduces our average land acquisition costs. In addition, we believe our ability to acquire land at low cost

is also attributable to our flexible property development capabilities that have enabled us to develop a wide variety of land and properties. We believe our operating flexibility as to the size and location of the land that we can develop enables us to take the opportunity presented to us to acquire land at low cost. We conduct research and analysis and try to identify the future growth potential of a land site for our property development before our competitors start doing the same so as to avoid price competition. Such approach to land selection and evaluation has also contributed to our ability to acquire land at relatively low cost. We believe our ability to acquire high quality land at a relatively low cost allows us to use our working capital more efficiently, maintain a healthy profit margin and respond more effectively to changing market conditions.

#### ***Strong business model with track record of success***

We have a strong property development capability to develop a wide range of properties in different regions. We target affluent middle- to upper- class individuals and families and fast-growing small- to medium-sized enterprises. We focus our development capabilities on urban complexes and boutique upscale residences to meet the demand of our target customers. We have replicated our success in various markets in China while continuing to quickly and effectively develop a diverse range of high-quality properties to satisfy the requirements of our target customers in various markets in China. For example, we have successfully developed urban complexes such as Shenzhen Funian Plaza (深圳福年廣場), Chengdu MIC Plaza (formerly known as Chengdu Meinian International Plaza, 成都美年國際廣場) and Tianjin Future Plaza (天津香年廣場), and boutique upscale residences such as Guilin Lakeside Eden (麓湖國際社區), Suzhou Lago Paradise (蘇州太湖天城) and Dongguan Mont Conquerant (東莞君山), some of which are award-winning properties. We believe our capabilities to develop quality products provide us with significant leverage for our future business growth.

#### ***Well-known brand name***

We believe we have established a strong brand name in the property market in China. We have focused our property development efforts on developing a portfolio of properties as well as providing real estate services that cater to the diverse needs of our targeted customers. We believe these efforts have allowed us to achieve a strong track record in the sale of our properties. We have also focused on developing properties with a distinctive design or with features that can help to raise our company profile. We have worked closely with leading domestic and international architecture and design firms to achieve such goal. As a result, we have received numerous accolades for our property development and service capabilities, as well as for the design of our properties, and have achieved a strong market position in certain of our targeted regions. We believe our customers associate our brand image with high-quality and customer-oriented real estate products and services, as well as the modern and trend-setting design of our properties.

We have also established an annual program named “Fantasia — Voyage to Happiness” (幸福之旅 (“Voyage to Happiness”). Voyage to Happiness is a large scale community art activity organized by the Company since 2006, which explores the meaning of “Happiness” within the contemporary Chinese society through artistic creation and exchanges of ideas with the collaboration of a young artist each year. We believe such an effort attaches an artistic and cultural image to our brand and our properties in the mind of our target customers, distinguishing us from our competitors.

#### ***Strong value-accretion property development and service capabilities***

We believe that our urban complex developments help to foster increased property development activities by others and increased government investment in public infrastructure and services in surrounding neighborhoods and thus facilitate the formation of new urban centers, which in turn increases the value of our developments. We also provide real estate services that consist of property operation services and property agency services. We believe our property operation services enhance the value and attractiveness of our properties, thereby allowing us to increase average selling and rental prices. Our property agency services business allows us to better understand the market place so we can adjust our marketing and pricing strategies to achieve an optimum pricing for our properties. We believe our real estate services provide us with benefits that cannot be easily replicated by other property developers in China that are not also engaged in the property agency services business, which positions us well in the competitive real estate market in China.

***Experienced and stable management team with proven track record supported by seasoned professional employees***

The significant growth of our business since our inception is in large part due to our experienced and stable management team. Mr. Pan, our chairman and chief executive officer, and Ms. Zeng, our executive director, each has over 16 years of experience in real estate development in China, and, along with other members of our senior management team and employees, have established strong relationships with key industry participants. We have been able to capitalize on the collective expertise of our management and other professional employees so that we can develop and sell properties that appeal to our targeted customers at various locations. We believe that we have benefited, and will continue to benefit, from our management's extensive experience and knowledge of the PRC property market.

**Business Strategies**

***Continue to expand in fast-growing economic regions in China and selectively acquire low-cost land***

We plan to continue to concentrate the growth of our business in the four economically prosperous regions in China in which we currently operate. We believe each of the Chengdu-Chongqing Economic Zone, the Pearl River Delta region, the Yangtze River Delta region and the Beijing-Tianjin metropolitan region continues to provide attractive opportunities for property development. We intend to procure more low-cost land in each of these regions by adhering to our disciplined approach. Under such approach, a decision to make a land acquisition is made only after comprehensive in-depth market research and analysis and the completion of strict internal review procedures.

We believe that our property agency services business allows us to better understand the property market in China, to tailor our product offerings that appeal to our targeted customers and to adjust our marketing and pricing strategies to achieve optimum pricing for our properties, an advantage that cannot be easily replicated by property developers that are not also engaged in property agency services business. Going forward, we intend to continue to capitalize on our extensive experience and market knowledge gained from our property agency services business to selectively identify and acquire land for development.

***Focus on further improving the intrinsic synergies of our real estate products and value-added services***

We intend to focus on realizing increased synergies among our businesses, a crucial part to our Group's overall success. We intend to continue concentrating on developing urban complexes and boutique upscale residences. We believe our focus on these two types of property development projects allows us to better and more efficiently use our resources to address our target customers' needs and develop long-term business relationships. Our development focus also serves to increase the synergies that can be achieved among each aspect of our businesses. We plan to continue to expand our investment property portfolio by including boutique hotels in the properties that we develop, thereby increasing our recurring income as well as increasing the real estate solutions that we provide to customers. We have also established subsidiaries dedicated to providing hotel services, which we believe also helps to enhance the capabilities of our property operation services provided to more traditional properties, as well as to our urban complexes. We plan to continue to enhance cooperation among our businesses. For example, leveraging on our experience and expertise from our property development business, we have expanded into and plan to continue to expand hotel services and property community services and other value-added property businesses. We expect that our efforts should allow us to increase the breadth and stability of our revenue streams, reduce our overall exposure to volatility within and reliance on one sector of the real estate property industry and create cross-selling opportunities.

***Continue to improve our property operation service and hotel service capabilities to further increase the attractiveness and value of our properties***

Our property operation services are an important part of our business and serve a critical role in enhancing the value and environment of our developments, which in turn increases the rental income and

the average selling price of our properties. In early 2011, we commenced to reorganize our property operation services business and since then, have been providing property operation services through our subsidiary Colour Life and its subsidiaries. We have designated “Colour Life” as our brand for middle-to-high end property management and property community services. We intend to continue to strengthen our property operation services and strive to offer the highest level of services to tenants and residents and to achieve customer satisfaction.

We started our hotel service business in 2008 by establishing our own hotel management companies. We have entered into agreements with third party international professionals to operate and manage one of our boutique hotels under development. We believe such agreements will allow us to be exposed to the inner workings of operating and managing a boutique hotel and refine the level of hotel services that we provide. In addition, we believe as our hotel services continue to strengthen, the capabilities of our property operation services will also be enhanced as well. Our goal is to establish high quality and distinctive hotel services and further improve our property operation services. We intend to continue to improve the internet information platform of our property operation services to offer additional value-added services such as online payment options, customized online services for ordering goods and services and accessing real estate market information or brokerage listings. Furthermore, we intend to actively work to expand GFA under management, as well as enhance the capabilities of our building and equipment installation, maintenance and repair services. Finally, we seek to continue to improve the membership program we offer for purchasers of our properties, the Fantasia Club, by providing greater support for and better communication with our purchasers. Continuing to enhance the quality and offering of our property operation services will also serve us well in strengthening our relationships with our key clients and increasing potential referrals among our target customers.

#### *Continue to promote our brand names*

We place significant emphasis on developing our brand image and will continue to introduce real estate products and service offerings that will enhance our profile, reputation and image. We have worked closely with leading domestic and international architecture and design firms, such as Shenzhen Cube Architecture Design Office, China Southwest Architectural Design and Research Institute Corp. Ltd., AECOM, Earth Asia Design Group (Shanghai) Co., Ltd., RTKL Associates Inc., Kengo Kuma and Associates, Kenneth Ko Designs Ltd., Steve Leung Designers Ltd., PAL Design Consultants Ltd. and Woods Bagot Asia Limited in creating products that reflect the spirit and essence of our vision and assimilate the latest trends and elements, and will continue to do so in the future.

We intend to continue to employ strict quality control standards and to closely monitor the product quality and the workmanship of our contractors throughout the development process. We also plan to continue to actively participate in the selection of the materials used in our projects in order to achieve desired quality levels and to maintain a cohesive brand image for our properties. In addition, we intend to continue to rigorously monitor and protect our trademarks that we consider essential to our brand image. We will also continue our annual program, Happiness Discovery Trip (發現幸福之旅), to further foster customer awareness as to the artistic and cultural aspects of our brand image. We believe by cultivating a distinctive brand image, we will be able to further enhance our ability to attract our target customers and reinforce such customers’ perception of the quality, distinctiveness and comprehensiveness of our products and services.

### **Our Property Development Projects**

#### *Overview*

As of December 31, 2012, we had 40 property development projects at various stages of development. Based on the stage of development, we divide our property developments projects into three categories:

- completed projects, comprising properties for which we have received the requisite completion inspection report from the relevant government construction authority;
- projects under development, comprising properties for which we have obtained the requisite construction works commencement permits but are yet to receive the requisite completion inspection report; and

- projects held for future development, comprising properties for which we have obtained the relevant land use rights certificates and started preliminary design work but have not yet received the required construction works commencement permits, as well as properties for which we have not obtained the land use rights certificates but have entered into contractual agreements to obtain the relevant land use rights certificates and started preliminary design work.

In addition to our property development projects under various stages that are included in the above categories, we have also been actively exploring additional property development opportunities. Subsequent to December 31, 2012, we have entered into certain framework agreements and formal agreements with local government authorities and relevant third parties in relation to acquisition of parcels of land which occupy an aggregate site area of approximately 257,399 square meters with an aggregate planned GFA of approximately 851,484 square meters. We have not yet entered into any detailed agreements to obtain the relevant land use rights certificates for these potential new projects.

For development projects that are comprised of multiple-phase developments on a rolling basis, each phase is considered individually and classified as completed, under development or for future development, depending on whether the relevant completed construction work certified report or the required construction works commencement permit has been obtained for such phase.

We calculate the site area of our projects or phases as follows:

- for projects or phases for which we have obtained land use rights, based on the relevant land use rights certificates, and
- for projects or phases for which we have not obtained land use rights, based on the relevant contractual agreements.

We calculate the total GFA of our projects or phases as follows:

- for projects or phases that are completed, based upon relevant property surveying reports;
- for projects or phases that are not completed but for which pre-sale has commenced, based upon relevant inspection reports required for pre-sale;
- for projects or phases that are under development and for which we have not obtained relevant inspection reports but have obtained the relevant construction works planning permits, based on such construction works planning permits; and
- for projects or phases for which we have not received the relevant construction works planning permits, based on the total GFA indicated in property master plans approved by relevant government authorities or based on our internal records and development plans, which may be subject to change.

We calculate the site area and the total GFA for each phase in a project based on our own internal records and estimates except in circumstances where such information for a particular phase is contained in the relevant land use rights certificate, construction works planning permit, or completion inspection report.

Total GFA as used in this offering memorandum is comprised of saleable GFA and non-saleable GFA. Saleable GFA as used in this offering memorandum refers to the internal floor areas exclusive of non-saleable GFA. Non-saleable GFA as used in this offering memorandum refers to certain communal facilities and ancillary facilities, such as certain underground GFA and spaces for local community management committees and public security offices. Saleable GFA is divided into saleable GFA sold or pre-sold and saleable GFA unsold. A property is considered sold after we have executed the purchase contract with a customer and have delivered the property to the customer. The property is delivered to the customer upon the property being completed, inspected and accepted as qualified. Properties are pre-sold

when we have executed the purchase contract but have not yet delivered the properties to the customer. Saleable GFA unsold is further divided into GFA unsold and held for sale and GFA unsold and held for investment.

We calculate the saleable GFA for our projects or phases as follows:

- for projects or phases that are completed, based on the saleable GFA as determined upon relevant property surveying reports;
- for projects or phases that have not received the completion inspection report upon completion but have obtained the relevant inspection reports required for pre-sale, based on the saleable GFA in such relevant inspection reports;
- for projects or phases that have not received the relevant inspection reports required for pre-sale but have received relevant construction works planning permits, based on the construction works planning permits; and
- for projects or phases that have not received relevant construction works planning permits, based on the total GFA indicated in property master plans approved by relevant government authorities or based on our internal records and development plans, which may be subject to change.

Furthermore, the following information that appears in this offering memorandum is also based on our internal records and estimates: (i) saleable GFA sold or pre-sold, saleable GFA unsold, saleable GFA unsold and held for sale, saleable GFA unsold and held for investment, and (ii) information regarding expected completion and pre-sale commencement date and number of residential units, office space, commercial units and car parking spaces.

During the three-year period ended December 31, 2012, we did not terminate or void any purchase contracts due to delay in delivering properties to our customers based on the time frame set forth in the respective contracts. In addition, development costs for each of our projects were within their respective budgets during such period.

The following table sets forth information as to the site area and the GFA in square meters for each of our property development projects or its respective phases and its completion date or expected completion as of dates indicated:

Projects/Phases	Site Area	Total Saleable GFA Unsold		Our Interest in the Project	Actual or Expected Construction Commencement Date	Actual or Expected Completion Date	Actual or Expected Pre-sale Commencement Date	Types of Properties <sup>(1)</sup>
		Held for Sale	Held for Investment or for Hotel Management					
<b>Completed Projects/Phases</b>								
<b>Shenzhen:</b>								
Shenzhen Funiang Plaza (深圳福年廣場)	18,718	745	23,456	100%	July 2011	July 2012	March 2012	O
<b>Dongguan:</b>								
Dongguan Wonderland (東莞江山花園) (Phase 1)	96,863 <sup>(2)</sup>	371	-	100%	February 2011	October 2012	May 2011	R, C, P
<b>Huizhou:</b>								
Huizhou Fantasia Special Town (惠州別樣城) (Phase 2)	172,000 <sup>(2)</sup>	12,955 <sup>1</sup>	-	100%	September 2011	December 2012	September 2011	R, C
<b>Chengdu:</b>								
Chengdu Fantasia Town (成都花樣城) (Phase 3)	126,667 <sup>(2)</sup>	178	-	100%	January 2011	November 2012	April 2011	R, C, P
Chengdu Belle Epoque (成都君山) (Phase 2.1)	491,209 <sup>(2)</sup>	4,602	11,200	100%	July 2011	September 2012	December 2011	R, C
Chengdu Future Plaza (成都香年廣場)	13,863	68,659	9,000	100%	March 2010	October 2012	October 2010	R, C, O
<b>Suzhou:</b>								
Suzhou Lago Paradise (蘇州太湖天城) (Land Plot No.6)	111,107 <sup>(2)</sup>	15,016	-	100%	March 2011	June 2012	April 2011	R, C
<b>Wuxi:</b>								
Wuxi Love Forever (無錫花郡) (Phase 1)	123,670 <sup>(2)</sup>	17,925	-	100%	January 2011	December 2012	June 2011	R, C
<b>Tianjin:</b>								
Tianjin Future Plaza (天津香年廣場)	15,409	2,404	-	100%	August 2010	October 2012	December 2010	R, O, C, P
<b>Subtotal:</b>	<b>1,169,506</b>	<b>122,855</b>	<b>43,656</b>					

As of December 31, 2012

Projects/Phases	Site Area	Held for Sale	Total Saleable GFA Unsold		Our Interest in the Project	Actual or Expected Construction Commencement Date	Actual or Expected Completion Date	Actual or Expected Pre-sale Commencement Date	Types of Properties <sup>(1)</sup>
			Held for Investment or for Hotel Management	Total Saleable GFA Sold					
<b>Project/Phases Under Development</b>									
<b>Huizhou:</b>									
Huizhou Fantasia Special Town (惠州別業城) (Phase 3) . . . . .	172,000 <sup>(2)</sup>	76,328	-	-	100%	June 2012	March 2014	December 2012	R, C
Huizhou Love Forever (惠州花郡) (Phases 1 and 2) . . . . .	40,000 <sup>(2)</sup>	91,784	-	-	100%	July 2012	April 2014 (Phase 1) December 2014 (Phase 2)	August 2012	R, C
<b>Dongguan:</b>									
Dongguan Wonderland (東莞江山花園) (Phases 2 and 3) . . . . .	96,863 <sup>(2)</sup>	43,379	-	-	100%	February 2011 (Phase 2) March 2012 (Phase 3)	September 2013 (Phase 2) June 2014 (Phase 3)	December 2011 (Phase 2) September 2012 (Phase 3)	R, C, P
<b>Guilin:</b>									
Guilin Fantasia Town (桂林花漾城) (Phase 1) . . . . .	190,591 <sup>(2)</sup>	93,773	70,523	-	100%	May 2011	March 2013 (Phase 1.1) June 2013 (Phase 1.2) June 2014 (Phase 1.3)	June 2011	R, C, H, P
Guilin Lakeside Eden (桂林麓湖國際社區) (Phase 1.1) . . . . .	513,962 <sup>(2)</sup>	23,763	-	-	100%	March 2012	September 2014	May 2012	R, C
<b>Chengdu:</b>									
Chengdu Grande Valley (成都大溪谷) (Phase 2.2) . . . . .	909,225 <sup>(2)</sup>	2,160	-	-	100%	November 2012	March 2014	April 2013	R, C
Chengdu Daxigu Fupeng Hotel (成都大溪谷福朋酒店) . . . . .	16,447	-	33,700	-	100%	December 2012	March 2016	N/A	H
Chengdu Fantasia Town (成都花漾城) (Phases 4.1 and 4.2) . . . . .	126,667 <sup>(2)</sup>	30,747	-	-	100%	March 2012	December 2013 (Phase 4.1) June 2014 (Phase 4.2)	April 2012	R, C, P



As of December 31, 2012

Projects/Phases	Total Saleable GFA Unsold			Site Area	Held for Investment or Management		Total Saleable GFA Sold	Total Saleable GFA Pre-sold	Our Interest in the Project	Actual or Expected Construction Commencement Date	Actual or Expected Completion Date	Actual or Expected Pre-sale Commencement Date	Types of Properties <sup>(1)</sup>
	Held for Sale	Investment	Management										
Chengdu Funiang Plaza (成都福年廣場)	21,555	-	-	16,564	-	-	-	110,562	100%	February 2011	October 2013	June 2011	R, C
Chengdu MIC Plaza (成都美年國際廣場) (Phase 2)	343,735	30,000	-	170,032 <sup>(2)</sup>	-	-	-	-	100%	April 2012	June 2016	November 2012	R, O, C, H, P
Chengdu Longnian International Centre (成都龍年國際中心) (Phase 1)	117,926	93,500	-	208,500 <sup>(2)</sup>	-	-	-	4,349	100%	November 2012	December 2014	November 2012	R, C
<b>Dali:</b>													
Dali Human Art Wisdom (大理藝墅花鄉)	16,235	-	-	9,213	-	-	-	33,759	100%	June 2011	June 2013	September 2011	R, C, O, P
<b>Tianjin:</b>													
Tianjin Love Forever (Phase 1.1)	16,313	-	-	361,546 <sup>(2)</sup>	-	-	-	10,828	100%	December 2011	September 2013	December 2011	R, C, P
<b>Suzhou:</b>													
Suzhou Lago Paradise (蘇州太湖天城) (Land Plot No. 4 and No. 6)	35,242	-	-	111,107 <sup>(2)</sup>	-	-	-	18,876	100%	November 2011 (Plot No. 4) March 2011 (Plot No. 6)	June 2013 (Plot No. 4) June 2014 (Plot No. 6)	November 2011 (Plot No. 4) July 2011 (Plot No. 6)	R, C
<b>Wuxi:</b>													
Wuxi Love Forever (無錫花郡) (Phases 2 and 3)	139,075	-	-	123,670 <sup>(2)</sup>	-	-	-	2,171	100%	January 2011 (Phase 2) August 2011 (Phase 3)	December 2013 (Phase 2) May 2015 (Phase 3)	June 2012 (Phase 2) May 2013 (Phase 3)	R, C
Wuxi Hailun Complex (無錫喜年中心)	68,949	-	-	12,789	-	-	-	2,401	100%	December 2011	December 2013	June 2012	R, O, C
<b>Nanjing:</b>													
Nanjing Yuhuatai Project (南京花生唐)	20,391	-	-	55,419 <sup>(2)</sup>	-	-	-	2,696	100%	April 2012	June 2013	April 2012	C, P
<b>Subtotal:</b>	<b>1,141,355</b>	<b>227,723</b>	<b>-</b>	<b>3,134,595</b>	<b>-</b>	<b>-</b>	<b>-</b>	<b>626,447</b>					

As of December 31, 2012

Projects/Phases	Total Saleable GFA Unsold				Site Area	Held for Sale	Held for Investment or for Hotel Management	Total Saleable GFA Sold	Total Saleable GFA Pre-sold	Our Interest in the Project	Actual or Expected Construction Commencement Date	Actual or Expected Completion Date	Actual or Expected Pre-sale Commencement Date	Types of Properties <sup>(1)</sup>
<b>New projects to be developed</b>														
<b>Shenzhen:</b>														
Shenzhen Topsearch Project (深圳至卓大廈項目) . . . . .	11,209	77,500	20,000	-	-	-	-	-	-	61%	N/A	N/A	N/A	C, O
Shenzhen TCL Project (深圳南山區項目) . . . . .	17,990	39,587	-	-	-	-	-	-	-	100%	N/A	N/A	N/A	C, O
<b>Huizhou:</b>														
Huizhou Fantasia Special Town (惠州別樣城) (All remaining phases) . . . . .	172,000 <sup>(2)</sup>	253,532	-	-	-	-	-	-	-	100%	N/A	N/A	N/A	R, C
<b>Guilin:</b>														
Guilin Fantasia Town (桂林花漾城) (All remaining phases) . . . . .	190,591 <sup>(2)</sup>	239,726	-	-	-	-	-	-	-	100%	N/A	N/A	N/A	R, C
Guilin Lakeside Eden (桂林龍湖國際社區) (All remaining phases) . . . . .	513,962 <sup>(2)</sup>	1,594,101	-	-	-	-	-	-	-	100%	N/A	N/A	N/A	R, C
<b>Chengdu:</b>														
Chengdu Grande Valley (成都大溪谷) (All remaining phases) . . . . .	909,225 <sup>(2)</sup>	1,516,370	-	-	-	-	-	-	-	100%	N/A	N/A	N/A	R, C
Chengdu MIC Plaza (成都美年國際廣場) (All remaining phases) . . . . .	170,032 <sup>(2)</sup>	24,973	31,000	-	-	-	-	-	-	100%	N/A	N/A	N/A	R, O, C
Chengdu Belle Epoque (成都君山) (All remaining phases) . . . . .	491,209 <sup>(2)</sup>	283,304	-	-	-	-	-	-	-	100%	N/A	N/A	N/A	R, C
Chengdu Longnian International Centre (成都龍年國際中心) (All remaining phases) . . . . .	208,500 <sup>(2)</sup>	184,726	18,200	-	-	-	-	-	-	100%	N/A	N/A	N/A	R, C
<b>Beijing:</b>														
Beijing Qingnian Road Project (北京青年路項目) . . . . .	17,138	82,395	22,412	-	-	-	-	-	-	100%	N/A	N/A	N/A	C, O, P
<b>Tianjin:</b>														
Tianjin Yingcheng Lake Project (天津營城湖項目) . . . . .	100,000	168,339	-	-	-	-	-	-	-	100%	N/A	N/A	N/A	R, C

As of December 31, 2012

Projects/Phases	Total Saleable GFA Unsold		Site Area	Held for Investment or Management		Total Saleable GFA Sold	Total Saleable GFA Pre-sold	Our Interest in the Project	Actual or Expected Construction Commencement Date	Actual or Expected Completion Date	Actual or Expected Pre-sale Commencement Date	Types of Properties <sup>(1)</sup>
	Held for Sale	Investment or Management		Held for Sale	Management							
Tianjin Love Forever (天津花郡) (All remaining phases)	467,291	-	361,546 <sup>(2)</sup>	-	-	-	-	100%	N/A	N/A	N/A	R
<b>Suzhou:</b>												
Suzhou Lago Paradise (蘇州太湖天城) (All remaining phases)	344,814	-	111,107 <sup>(2)</sup>	-	-	-	-	100%	N/A	N/A	N/A	R, C
<b>Wuxi:</b>												
Wuxi Love Forever (無錫花郡) (All remaining phases)	19,420	-	123,670 <sup>(2)</sup>	-	-	-	-	100%	N/A	N/A	N/A	R, C
<b>Subtotal:</b>	<u>5,296,078</u>	<u>91,612</u>	<u>3,398,179</u>	<u>-</u>	<u>-</u>	<u>-</u>	<u>-</u>					

Notes:

- (1) Types of properties include: (i) "R," which stands for "residential"; (ii) "C," which stands for "commercial"; (iii) "O," which stands for "office and others," including office, industrial and warehouse; (iv) "H," which stands for "hotel"; and (v) "P," which stands for "car park" and "basement area."
- (2) The site area information of this project represents the aggregate site area of all phases of this project.

The classification of properties in this offering memorandum is different from the classification of properties in the consolidated financial statements included in this offering memorandum.

Some of the information contained in the above table and the following descriptions of the individual projects and elsewhere in this offering memorandum may differ from our consolidated financial statements and the notes thereto included elsewhere in this offering memorandum because, among other things:

- properties that have been sold are not included in the consolidated statements of financial position and the notes thereto;
- saleable GFA unsold under our classification only include saleable GFA that have not been sold or pre-sold while “completed properties for sale” as used in our consolidated financial statements and the notes thereto, which is recorded under “properties for sale” on the consolidated statements of financial position, include properties that have not been contracted to be sold and properties pre-sold but have not been delivered to customers; and
- “properties for sale” and “investment properties” as recorded on our consolidated statements of financial position and the notes thereto include “completed properties for sale,” “properties under development,” “completed investment properties” and “investment properties under development” which include all properties that we classify as projects or phases under development whether we intend to hold such properties for sales or for investment after completion.

The table below sets forth our classification of properties and the corresponding classification of properties in our consolidated financial statements and the notes thereto contained in this offering memorandum:

<b>Types of Properties</b>	<b>Offering memorandum</b>	<b>Consolidated financial statements</b>
<ul style="list-style-type: none"> <li>• Properties for which we have received the completed construction works certified report from the relevant government construction authorities</li> </ul>	<ul style="list-style-type: none"> <li>• Completed projects</li> </ul>	<ul style="list-style-type: none"> <li>• Completed properties for sale (excludes completed properties that have been sold)</li> </ul>
<ul style="list-style-type: none"> <li>• Properties for which we have obtained the required construction works commencement permits but are yet to receive the completed construction works certified report</li> </ul>	<ul style="list-style-type: none"> <li>• Properties under development</li> </ul>	<ul style="list-style-type: none"> <li>• Completed investment properties</li> <li>• Properties for sale – Under development</li> <li>• Investment properties under development</li> </ul>
<ul style="list-style-type: none"> <li>• Properties for which we have obtained the relevant land use rights certificates and started preliminary design work but have not yet received the required construction works commencement permits</li> </ul>	<ul style="list-style-type: none"> <li>• Future development projects – land use rights obtained</li> </ul>	<ul style="list-style-type: none"> <li>• Properties for sale – Under development</li> <li>• Investment properties under development</li> </ul>
<ul style="list-style-type: none"> <li>• Properties for which we have not obtained land use rights certificates but have entered into contractual agreements to obtain the relevant land use rights certificates and started preliminary design work</li> </ul>	<ul style="list-style-type: none"> <li>• Future development projects – property rights to be acquired and potential new property development projects</li> </ul>	<ul style="list-style-type: none"> <li>• Properties for sale – Under development</li> <li>• Investment properties under development</li> </ul>

The following are detailed descriptions of each of our projects as of December 31, 2012, unless otherwise indicated. For certain of these projects, we share land use and development rights with other entities in a prescribed proportion according to the relevant agreements. The commencement date relating to each project or each phase of a project refers to the date on which construction commenced. The completion date set out in the descriptions of our completed projects or phases refers to the date on which the completed construction works certified report was obtained for each project or each phase of a multi-phase project. For projects or phases under development or for future development, the completion date of a project or phase reflects our best estimate based on our current development plans.

### ***Shenzhen***

#### *Shenzhen Funian Plaza (深圳福年廣場)*

Shenzhen Funian Plaza (深圳福年廣場) is located in Shenzhen Futian Free Trade Zone, which has convenient access to the transportation network around Huanggang Border and the Guangzhou-Shenzhen Expressway. The project occupies a total site area of approximately 18,718 square meters with a total saleable GFA of approximately 46,793 square meters. We completed development of this project in July 2012. As of December 31, 2012, we had pre-sold saleable GFA of approximately 22,592 square meters, and held approximately 745 square meters for sale and approximately 23,456 square meters for investment or hotel management purposes.

#### *Shenzhen Topsearch Project (深圳至卓大廈項目)*

Shenzhen Topsearch Project (深圳至卓大廈項目) is located in Shekou of Shenzhen. The project occupies a total site area of 11,209 square meters with a planned saleable GFA of 97,500 square meters. As of December 31, 2012, all planned saleable GFA was held for future development.

#### *Shenzhen TCL Project (深圳南山區項目)*

Shenzhen TCL Project (深圳南山區項目) is located in Nanshan district of Shenzhen. The project occupies a total site area of 17,990 square meters with a planned saleable GFA of 39,587 square meters. As of December 31, 2012, all planned saleable GFA was held for future development.

### ***Dongguan***

#### *Dongguan Wonderland (東莞江山花園)*

Dongguan Wonderland (東莞江山花園) is a boutique upscale complex located in Huangjiang Town, Dongguan, Guangdong Province. The project occupies an aggregate site area of approximately 96,863 square meters with a planned saleable GFA of approximately 289,473 square meters. We commenced development of phases 1 and 2 of this project in February 2011 and phase 3 in March 2012. We completed phase 1 in October 2012 and phases 2 and 3 are expected to be completed in September 2013 and June 2014, respectively. As of December 31, 2012, we had pre-sold approximately 245,723 square meters of saleable GFA of phases 1, 2 and 3, held saleable GFA of approximately 371 square meters of phase 1 for sale and we were expected to hold approximately 43,379 square meters of saleable GFA of phases 2 and 3 for sale.

### ***Huizhou***

#### *Huizhou Fantasia Special Town (惠州別樣城)*

Huizhou Fantasia Special Town (惠州別樣城) is located to the east of Huinan Road in Huiyang, Huizhou, Guangdong Province. It is adjacent to Huiyang bus terminus and is within walking distance of the Danshui central business areas. The project occupies an aggregate site area of approximately 172,000 square meters with a planned saleable GFA of approximately 525,914 square meters. We completed development of phase 2 of this project in December 2012. As of December 31, 2012, we had pre-sold approximately 146,244 square meters of saleable GFA of phase 2 and held saleable GFA of approximately 12,955 square meters for sale.

We commenced development of phase 3 of this project in June 2012 and expect to complete it in March 2014. As of December 31, 2012, we had pre-sold approximately 36,855 square meters of saleable GFA of phase 3 and were expected to hold approximately 76,328 square meters of saleable GFA for sale.

As of December 31, 2012, saleable GFA of approximately 253,532 square meters was held for future development.

#### *Huizhou Love Forever (惠州花郡)*

Huizhou Love Forever (惠州花郡) is a mid- to high-end residence located on the outskirts of Daya Bay Center, Huizhou, Guangdong Province. The project occupies an aggregate site area of approximately

40,000 square meters with a planned saleable GFA of approximately 91,784 square meters. We commenced development of both phases 1 and 2 of this project in July 2012. Phases 1 and 2 are expected to be completed in April 2014 and December 2014, respectively. As of December 31, 2012, all planned saleable GFA was expected to hold for sale.

### *Chengdu*

#### *Chengdu Fantasia Town (成都花樣城)*

Chengdu Fantasia Town (成都花樣城) is a large-scale residential community located at Guangming Community, Jinma Town, Wenjiang District, Chengdu, Sichuan Province. Wenjiang District is one of the most developed residential areas in the suburbs of Chengdu. It has an established municipal infrastructure system and is conveniently linked to the center of Chengdu. It also enjoys a rich biological environment and beautiful scenery and is the site of several hot springs. The project occupies an aggregate site area of approximately 126,667 square meters with a planned saleable GFA of approximately 409,665 square meters. We completed development of phase 3 of this project in November 2012. As of December 31, 2012, we had pre-sold approximately 262,208 square meters of saleable GFA of phase 3 and held approximately 178 square meters for sale.

We commenced development of both phases 4.1 and 4.2 of this project in March 2012. Phase 4.1 and phase 4.2 are expected to be completed in December 2013 and June 2014, respectively. As of December 31, 2012, we had pre-sold approximately 116,532 square meters of saleable GFA of phases 4.1 and 4.2 and were expected to hold approximately 30,747 square meters for sale.

#### *Chengdu Belle Epoque (成都君山)*

Chengdu Belle Epoque (成都君山) is a large scale, low density residential community located in a famous tourist attraction in Yongshang Town, Xinjin County, Chengdu, Sichuan Province. It is approximately three kilometers away from the center of Yongshang Town, approximately seven kilometers from Chengdu-Ya'an Express Way, approximately 18 kilometers away from the airport, and approximately 39 kilometers away from the city center of Chengdu. The project occupies an aggregate site area of approximately 491,209 square meters with a planned saleable GFA of approximately 329,034 square meters. We completed development of phase 2.1 of this project in September 2012. As of December 2012, we had pre-sold approximately 224 square meters of saleable GFA of phase 2.1, were expected to hold approximately 4,602 square meters for sale and approximately 11,200 square meters for investment or for hotel management purposes.

As of December 31, 2012, saleable GFA of approximately 283,304 square meters was held for future development.

#### *Chengdu Future Plaza (成都香年廣場)*

Chengdu Future Plaza (成都香年廣場) comprises high-rise office buildings located in Jianshe, Shuangtu and Minle Villages, High-Technology Zone, Chengdu, Sichuan Province. The project occupies a total site area of approximately 13,863 square meters with a total saleable GFA of approximately 154,977 square meters. We completed development of this project in October 2012. As of December 31, 2012, we had pre-sold approximately 77,318 square meters of saleable GFA and held approximately 68,659 square meters of saleable GFA for sale and approximately 9,000 square meters for investment and hotel management purposes.

#### *Chengdu Grande Valley (成都大溪谷)*

Chengdu Grande Valley (成都大溪谷) is a large scale residential complex located in Jinhua and Qixin Villages, Heshan Town, Pujiang County, Chengdu, Sichuan Province. It is about one kilometer away from the exit of the Chengdu-Ya'an Express Way and is about a 40-minute drive to the city center of Chengdu. Pujiang County is also a national ecological model county and enjoys an exceptional advantage with regards to its natural surroundings. The project is surrounded by natural scenery, including Changqiu mountain with an area of about 20 square kilometers, and pristine lakes and wetlands with an area of about 200,000 square meters. The project occupies an aggregate site area of approximately 909,225 square meters with a planned saleable GFA of approximately 1,518,530 square meters. We commenced development of phase 2.2 of this project in November 2012, which is expected to be completed in March 2014. As of December 31, 2012, we were expected to hold approximately 2,160 square meters of saleable GFA of phase 2.2 for sale.

As of December 31, 2012, saleable GFA of approximately 1,516,370 square meters was held for future development.

### *Chengdu Daxigu Fupeng Hotel (成都大溪谷福朋酒店)*

Chengdu Daxigu Fupeng Hotel (成都大溪谷福朋酒店) is located in Pujiang County, Chengdu, Sichuan Province. The project occupies a total site area of approximately 16,447 square meters with a planned saleable GFA of 33,700 square meters. We commenced development of this project in December 2012 and expect to complete it in March 2016. As of December 31, 2012, we were expected to hold approximately 33,700 square meters of saleable GFA for investment or for hotel management purposes.

### *Chengdu Funian Plaza (成都福年廣場)*

Chengdu Funian Plaza (成都福年廣場) is an urban complex comprising high-rise office buildings, boutique residential buildings and a shopping mall located on the west side of Tianfu Avenue, South Yinghua Road, Chengdu, Sichuan Province. The project occupies a total site area of approximately 16,564 square meters with a planned saleable GFA of approximately 132,117 square meters. We commenced development of this project in February 2011, which is expected to be completed in October 2013. As of December 31, 2012, we had pre-sold approximately 110,562 square meters of saleable GFA and were expected to hold approximately 21,555 square meters of saleable GFA for sale.

### *Chengdu MIC Plaza (成都美年國際廣場)*

Chengdu MIC Plaza (formerly known as Chengdu Meinian International Plaza, 成都美年國際廣場) is a large urban complex located near the Fu river in the High-Technology Zone, Chengdu, Sichuan Province. The project occupies an aggregate site area of approximately 170,032 square meters with a planned saleable GFA of approximately 429,708 square meters. We commenced development of phase 2 of this project in April 2012 and expect to complete it in June 2016. As of December 31, 2012, we were expected to hold saleable GFA of phase 2 of approximately 343,735 square meters for sale and approximately 30,000 square meters for investment or hotel management purposes.

As of December 31, 2012, saleable GFA of approximately 55,973 square meters were held for future development.

### *Chengdu Longnian International Centre (成都龍年國際中心)*

Chengdu Longnian International Centre (成都龍年國際中心) is located in Pujiang Pitong Town, Pixian, Chengdu, Sichuan Province. The project occupies an aggregate site area of approximately 208,500 square meters with a planned saleable GFA of 418,701 square meters. We commenced development of phase 1 of this project in November 2012, which is expected to be completed in December 2014. As of December 31, 2012, we had pre-sold approximately 4,349 square meters of saleable GFA of phase 1, were expected to hold approximately 117,926 square meters of saleable GFA for sale and approximately 93,500 square meters for investment or for hotel management purposes.

As of December 31, 2012, saleable GFA of approximately 203,926 square meters were held for future development.

## ***Suzhou***

### *Suzhou Lago Paradise (蘇州太湖天城)*

Suzhou Lago Paradise (蘇州太湖天城) comprises accommodation and dining and residential buildings located in the Taihu National Tourism Vacation Zone in Suzhou City, Jiangsu Province. The project occupies an aggregate site area of approximately 111,107 square meters with a planned saleable GFA of approximately 437,310 square meters. The project is divided into land plots. We completed development of part of land plot no.6 of this project in June 2012. As of December 31, 2012, we had pre-sold approximately 23,362 square meters of saleable GFA in part of land plot no.6 and held approximately 15,016 square meters for sale.

We commenced development of land plot no.4 and the villa section of land plot no. 6 of this project in November 2011 and March 2011, respectively, which are expected to be completed in June 2013 and June 2014, respectively. As of December 31, 2012, we had pre-sold approximately 18,876 square meters of saleable GFA of land plot no.4 and the villa section of land plot no. 6, and were expected to hold approximately 35,242 square meters for sale.

As of December 31, 2012, saleable GFA of approximately 344,814 square meters, representing all other land plots within the project, was held for future development.

### ***Wuxi***

#### *Wuxi Love Forever (無錫花郡)*

Wuxi Love Forever (無錫花郡) is a boutique upscale residence located in a new district of Wuxi, Jiangsu Province. The project occupies an aggregate site area of approximately 123,670 square meters with a planned saleable GFA of approximately 244,852 square meters. We completed development of phase 1 of this project in December 2012. As of December 31, 2012, we had pre-sold approximately 66,261 square meters of saleable GFA and held approximately 17,925 square meters of saleable GFA of phase 1 for sale.

We commenced development of phases 2 and 3 of this project in January 2011 and August 2011, respectively. Phases 2 and 3 are expected to be completed in December 2013 and May 2015, respectively. As of December 31, 2012, we had pre-sold approximately 2,171 square meters of saleable GFA of both phases and were expected to hold approximately 139,075 square meters for sale.

As of December 31, 2012, saleable GFA of approximately 19,240 square meters was held for future development.

#### *Wuxi Hailrun Complex (無錫喜年中心)*

Wuxi Hailrun Complex (無錫喜年中心) is an urban complex located in Binhu District, Wuxi, Jiangsu Province. The project occupies a total site area of approximately 12,789 square meters with a planned saleable GFA of approximately 71,350 square meters. We commenced development of this project in December 2011, which is expected to be completed in December 2013. As of December 31, 2012, we had pre-sold approximately 2,401 square meters of saleable GFA and were expected to hold approximately 68,949 square meters for sale.

### ***Tianjin***

#### *Tianjin Future Plaza (天津香年廣場)*

Tianjin Future Plaza (天津香年廣場) is an urban complex located in Hexi District, Tianjin. The project occupies a total site area of approximately 15,409 square meters with a total saleable GFA of approximately 34,431 square meters. We completed development of this project in October 2012. As of December 31, 2012, we had pre-sold approximately 32,027 square meters of saleable GFA and held approximately 2,404 square meters for sale.

#### *Tianjin Love Forever (天津花郡)*

Tianjin Love Forever (天津花郡) is a boutique upscale residential community located in Wuqing District, Tianjin. The project occupies a total site area of approximately 361,546 square meters with a planned saleable GFA of approximately 494,432 square meters. We commenced development of phase 1.1 of this project in December 2011, which is expected to be completed in September 2013. As of December 31, 2012, we had pre-sold approximately 10,828 square meters of saleable GFA of phase 1.1 and were expected to hold approximately 16,313 square meters of saleable GFA for sale.

As of December 31, 2012, saleable GFA of approximately 467,291 square meters was held for future development.



### *Tianjin Yingcheng Lake Project (天津營城湖項目)*

Tianjin Yingcheng Lake Project (天津營城湖項目) is expected to be a residential community located to the south of Yingcheng Reservoir, Hangu District, Tianjin. The project is located within the New Coastal Area of Tianjin, which is a national level key development area in Tianjin, and is further within the sub-area of the New Coastal Area designated for leisure and tourism purposes. We believe the project may have a great prospect for value appreciation as an increasing number of tourist attractions and facilities are planned in the surrounding area. The project occupies a total site area of approximately 100,000 square meters with a planned saleable GFA of approximately 168,339 square meters. As of December 31, 2012, all planned saleable GFA was held for future development.

### **Guilin**

#### *Guilin Fantasia Town (桂林花樣城)*

Guilin Fantasia Town (桂林花樣城) is an urban complex located in Lingui New District, Guilin, Guangxi Province. The project occupies an aggregate site area of approximately 190,591 square meters with a planned saleable GFA of approximately 509,093 square meters. We commenced development of phases 1.1, 1.2 and 1.3 of this project in May 2011 and are expected to be completed in March 2013, June 2013 and June 2014, respectively. As of December 31, 2012, we had pre-sold approximately 105,071 square meters of saleable GFA of phases 1.1, 1.2 and 1.3 and were expected to hold saleable GFA of approximately 93,773 square meters for sale and approximately 70,523 square meters for investment or hotel management purposes, including the establishment of a five star hotel, Four Points by Sheraton.

As of December 31, 2012, saleable GFA of approximately 239,726 square meters was held for future development.

#### *Guilin Lakeside Eden (桂林麓湖國際社區)*

Guilin Lakeside Eden (桂林麓湖國際社區) is a boutique upscale complex located in Lingui New District, Guilin, Guangxi Province. The project occupies an aggregate site area of approximately 513,962 square meters with a planned saleable GFA of approximately 1,620,163 square meters. We commenced development of phase 1.1 of this project in March 2012, which is expected to be completed in September 2014. As of December 31, 2012, we had pre-sold saleable GFA of approximately 2,299 square meters and were expected to hold approximately 23,763 square meters for sale.

As of December 31, 2012, saleable GFA of approximately 1,594,101 square meters was held for future development.

### **Dali**

#### *Dali Human Art Wisdom (大理藝墅花鄉)*

Dali Human Art Wisdom (大理藝墅花鄉) is comprised of a mid- to high-end residences located near Butterfly Spring (蝴蝶泉), a famous tourist attraction, in Dali, Yunnan Province. The project occupies a total site area of approximately 9,213 square meters with a planned saleable GFA of approximately 49,994 square meters. We commenced development of this project in June 2011, which is expected to be completed in June 2013. As of December 31, 2012, we had pre-sold approximately 33,759 square meters of saleable GFA and were expected to hold approximately 16,235 square meters of saleable GFA for sale.

### **Nanjing**

#### *Nanjing Yuhuatai Project (南京花生唐)*

Nanjing Yuhuatai Project (南京花生唐) is an urban complex located in Yuhuatai District, Nanjing, Jiangsu Province. The project occupies a total site area of approximately 55,419 square meters with a planned saleable GFA of approximately 23,087 square meters. We commenced development of this project in April 2012, which is expected to be completed in June 2013. As of December 31, 2012, we had pre-sold saleable GFA of approximately 2,696 square meters and were expected to hold approximately 20,391 square meters for sale.

#### *Beijing Qingnian Road Project (北京青年路項目)*

Beijing Qingnian Road Project (北京青年路項目) is located on Qingnian Road of Beijing. The project occupies a total site area of 17,138 square meters with a planned saleable GFA of 104,807 square meters. As of December 31, 2012, all planned saleable GFA was held for future development.

## Potential New Property Development Projects

In addition to our existing property development projects, we are actively exploring opportunities for additional property development projects in China. Subsequent to December 31, 2012, we have entered into certain framework agreements and formal agreements with local government authorities and relevant third parties in relation to acquisition of parcels of land which occupy an aggregate site area of approximately 257,399 square meters with an aggregate planned GFA of approximately 851,484 square meters. We have not yet entered into any detailed agreements to obtain the relevant land use rights certificates for these potential new projects. We can not assure you that we will obtain any land use rights or any or all of the requisite governmental approvals for the development of these potential new projects. For more details on the risks associated with these potential new projects, please see “Risk Factors — Risks Relating to Our Business — We have entered into several preliminary framework agreements for potential new property development projects which are subject to significant risks and uncertainties” and “Our results of operations may be materially and adversely affected if we fail to obtain, or there are material delays in obtaining, requisite governmental approvals for our property developments” in this offering memorandum. Because these potential new property development projects are still at a very preliminary stage, we are not able to estimate the total development costs or set target completion dates for these potential new projects yet.

## Our Business Segments

Our business includes (i) property development, (ii) property investment, (iii) property operation services, (iv) property agency services and (v) hotel services. Our property operation services include property management services, building equipment installation, maintenance and repair services, information network services and other value-added services such as secondary property brokerage services after our disposal of Xingyan Property Consultancy. Historically, our Group provided dedicated property agency services through Xingyan Property Consultancy, in which we owned an 85% equity interest. Due to the restructuring of the Group’s business and in order for us to focus on our other major segments, we disposed of our entire 85% interest in Xingyan Property Consultancy in February 2011 to an independent third party. Our hotel services include hotel management and operation services. As of December 31, 2012, we and our PRC subsidiaries were in possession of all of the relevant approvals and qualification certificates required under PRC laws and regulations in order to conduct our businesses.

## Property Development

### Overview

Although the nature and sequences of specific planning and execution activities will vary among our different property development projects, the core stages typically involved in the development of our properties include opportunity identification, site selection and project planning, land acquisition, pre-construction preparations, project design, project construction and management, pre-sale, sales and marketing, and provision of after-sales services, which are illustrated below:

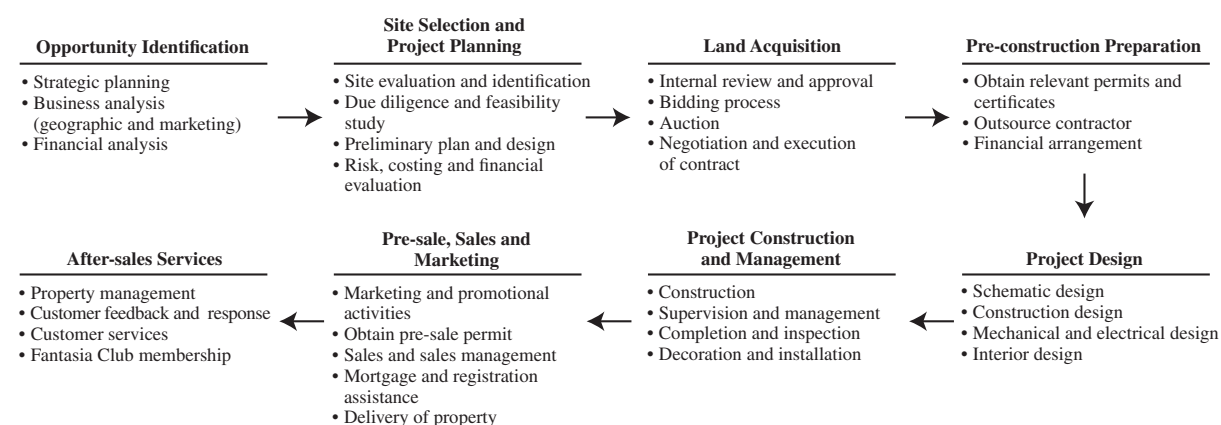

## ***Project Management***

We have established project companies to supervise and manage our property development projects in different cities or regions in China that we believe will best allow us to address the unique market associated with such cities or regions. The senior management of our Group works closely with the senior management of each of our project companies to provide guidance as to the overall strategic directions of our Group as well as to supervise and oversee the activities of each of the project companies. We have recently changed the management structure of our group. The following chart illustrates the management structure of our Group as of December 31, 2012:

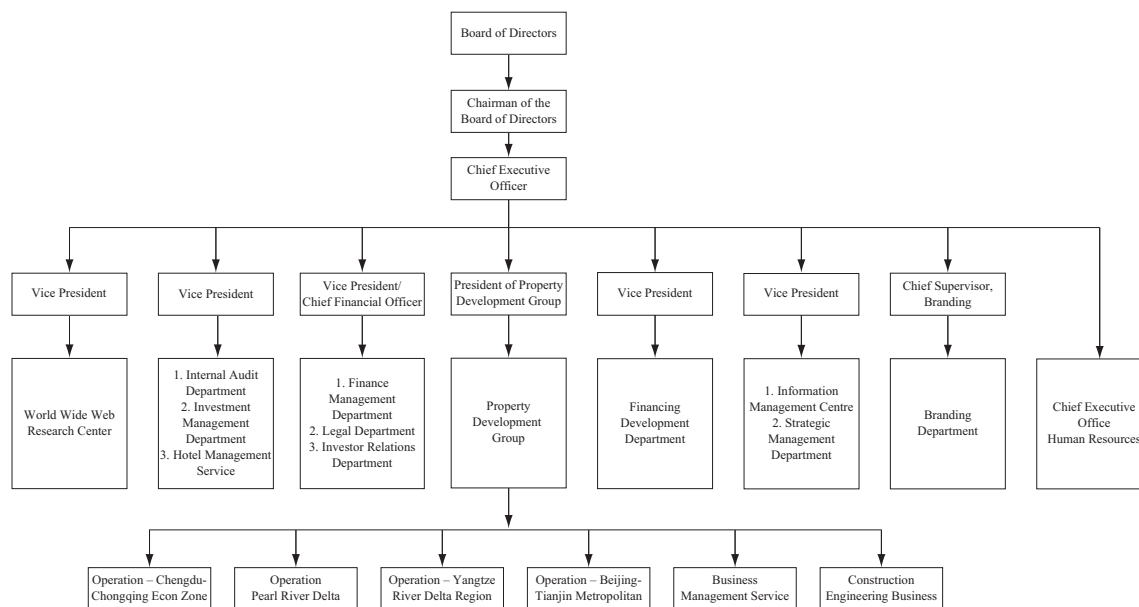

Our project companies have further established specialized divisions to supervise and manage the major stages of our property development activities. The divisions include the construction management division, market planning division, marketing management division, project budgeting division, finance management division and product design division. However, depending on the size and the type of projects, the specialized divisions between each project company may vary and for certain projects, the relevant market research, site selection and other pre-construction, design and construction decisions may be directly carried out by the senior management of the Group or through one of its divisions instead of by the project companies. Our project companies generally enjoy a certain level of autonomy in their daily business operating decisions without the prior approval of the Group's senior management. We believe such autonomy enhances our operating efficiency and allows us to optimize our capacities and resources as well as to leverage on the local knowledge of the management of each project company. However, major operating decisions, such as the purchase of land, the approval of projects for development and financing, are subject to the decision of the Group's senior management. We believe our management structure provides us with the ability to consolidate the resources of the Group to enhance our negotiating powers with certain suppliers and contractors, and facilitate the sharing of expertise among various projects in areas such as design, construction, marketing and sales.

## ***Opportunity Identification***

The first stage of our development process involves the identification of new opportunities for forthcoming land auctions or sales in strategic cities or regions in China. Our senior management and our business expansion and development division of our Group determine our strategic direction and our future project development plans. The business intelligence research and development department of our Group also conducts in-depth demographic and market research as to potential cities or regions in China into which we may consider entering. The selection criteria for suitable expansion opportunities are based on certain indicators, including, among others:

- population and urbanization growth rate;
- general economic condition and growth rate;

- disposable income and purchasing power of consumers;
- anticipated demand for residential and commercial properties and office spaces;
- availability of future land supply and land prices;
- cultural heritage of such city;
- local business environment and opportunities;
- availability of qualified personnel in such city or region and the willingness of our existing management personnel to relocate to such city or region;
- governmental urban planning and development policies; and
- overall competitive landscape.

### ***Site Selection***

We, through certain divisions of our property development business, are engaged in the research of property market conditions in the Pearl River Delta region, the Chengdu-Chongqing Economic Zone, the Yangtze River Delta region and the Beijing-Tianjin metropolitan region in an effort to identify and assess potential property development opportunities. Before selecting a parcel of land for development, we engage in comprehensive and in-depth market research and analysis to evaluate the market potential and value of the areas surrounding the land and the development potential of the land. Key factors that are considered during our land selection include, but are not limited to:

- size, shape and location of the parcel;
- transportation access and availability of infrastructural support;
- prospects of economic development in the area, government income GDP and social, economic and environmental conditions of the area;
- demand for properties in the relevant area, including pricing potentials;
- existing and potential property developments in the area;
- convenience of the site, such as proximity to the city center, airport, subway and commercial facilities;
- suitability of the site for our products;
- cost, investment and financial return, including cash flow and capital appreciation;
- the status of the land use rights with respect to the targeted site if acquired in the secondary market; and
- government development plans for the relevant site and neighboring area.

Furthermore, during land selection, we also consult with the relevant local authorities as to how the development of the targeted land can fit within the overall development plan of the region, city or area in which the land is located.

## *Land Acquisition*

We follow a strict procedure in the acquisition of properties. Prior to acquiring a property, our business intelligence research and development department, investment management department, legal department, financial management department and certain other departments must all review and approve such proposed acquisition. The proposed project, once vetted and approved by various departments and our chief executive officer, will be submitted to our board of directors for approval. If the proposed project is approved by the board of directors, we will then seek to acquire the land use rights within a pre-set budget.

We have historically obtained our land and will continue to obtain land through (i) acquisition of land use rights through government-organized tender, auction and listing-for-sale; (ii) establishing joint venture project companies; (iii) cooperatively developing projects with third parties; (iv) acquiring target companies which have acquired land use rights themselves; and (v) acquisition of projects under development from third party project companies. In both government bids and purchases in the secondary market, the purchase price typically includes all expenses required to deliver the land use rights.

The Rules regarding the Grant of State-Owned Land Use Rights by Way of Tender, Auction and Listing-for-sale (招標拍賣掛牌出讓國有土地使用權規定) issued by the Ministry of Land and Resources (the “MLR”), revised on September 21, 2007 and renamed as the Rules regarding the Grant of State-Owned Construction Land Use Rights by Way of Tender, Auction and Listing-for-sale (招標拍賣掛牌出讓國有建設用地使用權規定), which came into force on November 1, 2007, provide that state-owned land use rights for commercial use, tourism, entertainment and commodity housing development may be granted by the government only through competitive bidding, auction or listing-for-sale. If land use rights are granted by way of competitive bidding, the relevant land administration authority will issue a bidding announcement, inviting individuals, corporations and other organizations to participate in the tender. When deciding the grantee of the land use rights, the relevant authorities consider not only the tender price, but also the credit history and qualifications of the tenderer and the tender proposal. If land use rights are granted by way of auction, the relevant land administration authority will issue an auction announcement, and the bidders can, at a specified time and location, openly bid for the relevant parcel of land. If land use rights are granted by way of listing-for-sale, the relevant land administration authorities will announce the conditions for granting the land use rights at designated land transaction centers and bidders are invited to submit their bids in writing. The land use rights are granted to the bidder submitting the highest bid by the end of the listing-for-sale period. See “Regulation — I. Legal Supervision Relating to the Property Sector in the PRC — D. Development of a Property Project — (i) Land for property development.”

Under current regulations, original grantees of land use rights are typically allowed to transfer the land use rights granted to them provided that (i) the assignment price payable to the relevant government authorities has been fully paid in accordance with the assignment contract and a land use rights certificate has been obtained; and (ii) development has been carried out according to the assignment contract and, (iii) in the case of a project under development, development representing more than 25% of the total investment has been completed. If the land use rights are obtained by way of allocation, such land may be transferable upon approval by the relevant government authority. See “Regulation” for further details. Under current PRC laws and regulations, property development should be started no later than one year from the project commencement date stipulated in the relevant land grant contract and the development of the land should not be suspended for more than one year before we have completed one-third of the total GFA and invested more than one-fourth of the total estimated investment of the project. See “Regulation.”

Under current PRC laws and regulations, we may also obtain land use rights through the acquisition of project companies that already hold the relevant land use rights. We have obtained land use rights through such method for the following projects: Shenzhen Funian Plaza (深圳福年廣場), Dongguan Wonderland (東莞江山花園), Wuxi Hailun Complex (無錫喜年中心), Chengdu Fantasia Town (成都花樣城), Guilin Fantasia Town (桂林花樣城), Guilin Lakeside Eden (桂林麓湖國際社區), Chengdu Belle Epoque (成都君山), Chengdu Future Plaza (成都香年廣場), Yixing Town on the Water (宜興雲海間), Tianjin Yingcheng Lake (天津營城湖項目), Suzhou Taihu Project (蘇州太湖項目), Beijing Qingnian Road Project (北京青年路項目), Shenzhen Topsearch Building Project (深圳至卓大廈項目), Suzhou Yinzhuan Project (蘇州銀莊項目), Shanghai Xiangcheng Road Project (上海向城路項目) and Singapore Derbyshire Road Project.

## *Pre-Construction*

### *Permits and Certificates*

Once we have obtained the rights to develop a parcel of land, we will then begin to apply for the various permits and license that we need in order to begin construction and sale of our properties, which includes:

- land use rights certificate, which is a certification of the right of a party to use a parcel of land;
- construction land planning permit, which is a permit authorizing a developer to begin the survey, planning and design of a parcel of land;
- construction works planning permit, which is a certificate indicating government approval for a developer's overall planning and design of the project and allowing a developer to apply for a construction works commencement permit;
- construction works commencement permit, which is a permit required for commencement of construction; and
- pre-sale permit, which is a permit authorizing a developer to start the pre-sale of property still under construction.

As of December 31, 2012, we have obtained all the required land use rights certificates and permits for our existing properties under development, taking into account the respective stages of development at such date. In addition, we have obtained all land use rights certificates for our properties that are held for future development. We have also entered into preliminary framework agreements with the local government authorities and relevant third parties related to three potential new projects located in Pixian County, Chengdu, Sichuan Province; Dali, Yunnan Province and Suzhou, Jiangsu Province. We expect to enter into additional agreements related to those three projects in order to obtain the land use rights certificates.

### *Financing of Property Development*

Historically, our main sources of funding for our property development are internal funds, proceeds from pre-sales and sales of properties and borrowings from banks and other financial institutions. Our financing methods vary from project to project and are subject to limitations imposed by PRC regulations and monetary policies. See "Regulation — I. Legal Supervision Relating to the Property Sector in the PRC."

Since June 2003, commercial banks have been prohibited under PBOC guidelines from advancing loans to fund the payment of land premium. As a result, property developers may only use their own funds to pay for land premium. In the past, we typically financed the acquisition of land reserves from internal funds and proceeds from the pre-sale of properties, while our property development costs, including construction costs and additional financing for existing projects, are typically financed by internal funds, proceeds from the pre-sale of properties and project loans from PRC banks.

During the years ended December 31, 2010, 2011 and 2012, all of our payments of land premiums have been funded by internal funds and proceeds from the pre-sales of properties and equity and debt financing (other than project loans from PRC commercial banks). We typically use internal funds, proceeds from pre-sales and loans from PRC commercial banks to finance the construction costs for our property developments. From time to time, we also seek to obtain further funding to finance our project developments by accessing the international capital markets. We plan to use bank borrowings, internal funds, proceeds from the pre-sales and sales of our properties, and other cash generated from our operation to finance our future payments of property developments.

## *Design*

In order to provide our customers with distinctive designs and also to achieve operating efficiency, we outsource the design of substantially all of our property development projects to third party domestic or international architecture and design firms. We have worked closely with leading domestic and international architecture and design firms, such as Shenzhen Cube Architecture Design Office, China Southwest Architectural Design and Research Institute Corp. Ltd., AECOM, Earth Asia Design Group (Shanghai) Co., Ltd., RTKL Associates Inc., Kengo Kuma and Associates, Kenneth Ko Designs Ltd., Steve Leung Designers Ltd., PAL Design Consultants Ltd. and Woods Bagot Asia Limited. Our product design divisions are responsible for selecting third-party architecture and design firms, taking into consideration their reputation, proposed designs and their past relationship with us. From time to time, we also engage in a tender process in which the architecture and design firms submit proposals which we determine whether they can be translated into commercially viable projects. Our product design divisions supervise and provide the third-party architecture and design firms with certain directions and design criteria in which we aim to market our property development projects. In addition, our product design divisions work closely with the architecture and design firms in major aspects of the design process, from master planning, design specifications and adjustments, raw material selection, to ensuring that the designs are in compliance with local regulations. Our product design divisions monitor closely the work of the architecture and design firms to ensure that the project designs meet our specifications and work together with our project directors and our construction management divisions to ensure that any problems encountered with the proposed design during construction are resolved in a timely manner.

## *Project Construction and Management*

### *Construction and Procurement*

We outsource our project construction activities entirely to independent third-party contractors and subcontractors. To ensure the smooth cooperation between third-party contractors and us and high quality of construction work, we usually invite contractors to participate in a tender process. When selecting contractors, we consider the contractors' reputation, past performance, work quality, proposed delivery schedules, costs and current project type and profile and seek to maintain our construction costs at a reasonable level without sacrificing quality.

Our construction contracts are typically fixed price contracts that, except for certain provisions relating to the procurement of construction materials, provide for periodic payments during construction until a specified maximum percentage of the total contract sum is paid upon the completion of quality inspection. We generally retain a small portion of the contract price until the end of the warranty period as specified under the construction contracts to cover any potential expenses incurred as a result of any construction defects. However, under certain circumstances, the construction contracts also provide for bonus payment to the contractors if the construction is completed ahead of schedule. The construction contracts we enter into with construction companies also typically contain warranties with respect to quality and timely completion of the construction projects. We require construction companies to comply with PRC laws and regulations relating to the quality of construction as well as our own standards and specifications. A project director from our project companies is assigned to each project to monitor quality and cost control and construction progress closely during construction. In the event of a delay in construction or unsatisfactory quality of workmanship, we may require the construction companies to pay a penalty or provide other remedies. During the years ended December 31, 2010, 2011 and 2012, we have not experienced delay in construction or unsatisfactory quality of workmanship. In addition, as of December 31, 2012, we had not historically experienced any material disputes with any of our contractors.

A significant portion of the equipment and material used during construction are purchased by the contractors in accordance with the specifications provided by the design plan of the architecture and design firms and us. Certain materials, however, are purchased based on the joint consultation and selection between our contractors and us, such as cement. Furthermore, certain other equipment and materials, such as elevators, interior decoration materials and air conditioning systems, are purchased by us through our construction management divisions. Each transaction is initiated by a purchase order and the suppliers are asked to deliver the supplies to locations specified by the relevant property development

projects. Depending on factors such as costs, shipping expenses, convenience, quality and the type of equipment and materials needed for a particular project, each of our construction management divisions may purchase the same equipment and material from different suppliers or may combine to purchase from the same supplier to enhance our negotiating powers.

#### *Quality Control and Supervision*

We place a strong emphasis on quality control to ensure that our properties comply with relevant regulations, meet the specified standards and are of a high quality. Each project is assigned a project director with its own project management team, which is comprised of qualified engineers, including civil engineers, electrical engineers and sanitary engineers. Depending on the size and the nature of the project, there could be one or more than one such engineer in a given project. Our project management team perform on-site inspections and supervision on a day-to-day basis so as to ensure the workmanship and the quality of the material used by the contractors. The contractors are also subject to our quality control procedures, including appointment of internal on-site quality control engineers, examination of materials and supplies and on-site inspection. To maintain quality control, we employ strict procedures for the selection, inspection and testing of the equipment and materials that are purchased. Our project management teams inspect equipment and materials to ensure compliance with the contractual specifications before accepting the materials on site and approving payment. We reject equipment and materials that are below our standards or that do not comply with our specifications. We also engage independent supervisory companies to conduct quality and safety control checks on all building materials and workmanship on site. Finally, prior to handing over a property to a purchaser, our sales and customer service departments, together with our engineers and the relevant property management company, inspect the property to ensure the quality of the completed property.

#### *Pre-sale, Sales and Marketing*

We typically conduct pre-sales of our property units prior to the completion of a project or a project phase. Under relevant PRC regulations, we may engage in such preselling activities subject to satisfaction of certain requirements set forth in laws and regulations governing pre-sales of properties. These requirements include:

- the land premium must have been fully paid and the relevant land use rights certificates must have been obtained;
- the required construction works planning permits and the construction works commencement permits must have been obtained;
- the funds contributed to the property developments where property units are pre-sold may not be less than 25% of the total amount invested in a project and the progress and the expected completion date and delivery date of the construction work have been confirmed;
- pre-sale permits have been obtained from the construction bureaus at local levels; and
- the completion of certain milestones in the construction processes or other requirements as specified by the local government authorities.

These mandatory conditions are designed to require a certain level of capital expenditure and substantial progress in project construction before the commencement of pre-sales. Generally, the local governments also require developers and property purchasers to use standard pre-sale contracts prepared under the supervision of the local government. Developers are required to file all pre-sale contracts with local land bureaus and real estate administrations after entering into such contracts. We have complied with all the relevant pre-sale rules and regulations in the past in all material respects. See “Regulation — I. Legal Supervision Relating to the Property Sector of the PRC — E. Transfer and Sale of Property — (ii) Sale of commodity buildings — (a) Permit for Pre-sale of Commodity Buildings.”



Historically, the pre-sale, sales and marketing of our properties were conducted by our marketing management divisions and Xingyan Property Consultancy. Subsequent to the sale of Xingyan Property Consultancy in February 2011, we mainly cooperated with external property agency companies in marketing our projects. These property agency companies work closely with our marketing management divisions to conduct market research and analysis and formulate marketing plans and strategies, which we carefully evaluate and adopt as appropriate. Sales teams of such property agency companies are stationed at our projects' locations and carry out the actual selling activities, including contract signing and delivery logistics.

### *After-sales Services*

#### *Payment Arrangements*

We typically require our purchasers to pay a non-refundable deposit that is typically between 5% and 10% of the purchase price before entering into formal purchase contracts. If the purchasers later renege on the purchase contract, they will forfeit such deposit. Upon executing the purchase contracts, the purchasers are typically required to pay not less than 30% of the total purchase price of the property. If purchasers elect to make a lump-sum payment, the remaining purchase price balance is typically required to be paid no later than three months after the execution of the purchase contracts. Purchasers of our properties, including those purchasing pre-sale properties, may also arrange for mortgage loans with banks. As part of our sales efforts, we will assist our customers in arranging and providing information related to obtaining financing. If the purchasers elect to fund their purchases by mortgages, under current PRC laws and regulations, they may obtain mortgages of up to a maximum of 70% of the purchase price with a repayment period of up to 30 years. However, if the purchase is for a second or subsequent residential property and a bank loan was obtained to finance the purchaser's first property, then such purchaser may only obtain mortgages of up to 40%. For further purchases of properties, there would be continued downward adjustments on the percentage of the purchase price in which such purchaser can obtain a mortgage. In addition, banks may not lend to any individual borrower if the monthly repayment of the anticipated mortgage loan exceeds 50% of the individual borrower's monthly income or if the total debt service of the individual borrower exceeds 55% of such individual's monthly income. Purchasers are typically required to pay the remaining balance of the purchase price that is not covered by mortgages prior to the disbursement of mortgages from the banks. The payment terms of sales and pre-sales of properties are substantially identical. See "Regulation."

In accordance with industry practice, we provide guarantees to banks with respect to the mortgages offered to our purchasers upon requests of the banks. These guarantees are released upon (i) the relevant property certificates being delivered to the banks and completion of the relevant mortgage registrations, or (ii) the settlement of mortgage loans between the mortgagee banks and the purchasers of our projects. As of December 31, 2010, 2011 and 2012, our outstanding guarantees on the mortgage loans of our purchasers amounted to RMB1,689.8 million, RMB2,478.8 million and RMB2,750.8 million (US\$441.5 million), respectively, which were approximately 11.0%, 13.7% and 11.2%, respectively, of our total assets. The default rates on the repayment of our purchasers against the total guarantees we provided in connection with mortgage loans of our purchasers were negligible during the three-year period ended December 31, 2012. See "Risk Factors — Risks Relating to Our Business — We guarantee mortgage loans provided to our purchasers and may be to the mortgagee banks if our purchasers default on their mortgage loans." We do not conduct independent credit checks and due diligences on our purchasers when providing guarantees but instead rely on the credit checks conducted by the mortgage banks, and will typically require a higher initial payments from purchasers with less than ideal credit histories or purchasers whose mortgage is considered too high as compared to their income. In addition, for certain purchasers that have been delinquent in their other financing obligations, we may refuse to provide such guarantees. We believe that our outstanding guarantees on the mortgage loans of our purchasers are over-secured as we believe the aggregate fair value of the underlying properties exceeds the aggregate amount of outstanding guarantees.

### *Delivery and Other After-sales Services*

In addition to assisting our customers in arranging for and providing information relating to financing, we also assist our customers in various title registration procedures relating to their properties, including assisting them to obtain their property ownership certificates. We offer various communication channels to customers to obtain timely feedback about our products or services. Furthermore, we have established a membership program, the Fantasia Club (花樣會), in which purchasers of our properties are automatically enrolled. Such membership program provides our members with points when they purchase properties from us or recommend new customers to purchase our properties. In addition, membership points are provided through promotional activities and campaigns that we run from time to time. Membership points are redeemable for gifts or cash. We believe by establishing such membership program, we are better able to establish relationships with our customers and build customer loyalty, solicit customer feedback, generate sales leads and provide our members with a forum to share information relating to our properties and events and activities that are happening within our property communities.

We endeavor to deliver the units to our customers on a timely basis. We closely monitor the progress of the construction of our property projects and conduct pre-delivery property inspections to ensure timely delivery. The time frame for delivery is set out in the purchase contracts entered into with our customers, and we are subject to penalty payments to the purchasers for any delay in delivery caused by us. Once a property development has been completed, it must undergo inspection and receive relevant approvals from local authorities including planning bureaus, fire safety authorities and environmental protection authorities. Thereafter, the construction contractors arrange for final inspection by the property development authority. Within 15 days of the completion of the final inspection, the property developers must file a completion inspection report upon the completion of properties with the relevant property development authority, at which time the property is ready for delivery and we may hand over keys and possession of the properties to our customers. For additional information regarding the process of completion of a property project, please see “Regulation.” During the three-year period ended December 31, 2012, we have completed our construction and delivered the units to our customers based on our development schedule and the time frame for delivery set out in the purchase contracts.

Our Colour Life Group provides both traditional property management services to our properties, including security services, maintenance of properties and facilities and gardening, and modern community value-added services such as online commodity group-buying and delivery, commercial services and community resources integration. We currently provide property management services to all of the properties developed by us. We also provide property management services to properties developed by other developers.

For additional information as to our property management services, see “— Our Property Operation Business — Property Management Services.”

### *Commitments and Undertakings*

Our purchase contracts entered into with our purchasers typically require the properties to meet certain standards and also provide certain warranties to our purchasers. We typically represent or warrant to our purchasers that our properties are constructed in accordance with the current standards of construction and design, have passed quality inspection by the relevant local authorities and all components, equipment and facilities of the properties are performing in accordance with relevant standards. We also provide warranties to our purchasers to cover the foundations, primary structures, designs, roofs, exterior walls, wire, gas and water pipes, lighting and other electrical systems of our properties for a certain number of years in accordance with relevant local requirements and standards of the cities where our properties are located. For example, in Shenzhen, we warrant to our purchasers the foundations and the primary structures and designs of our properties for a term of 50 years, water leakage for roofs and exterior walls for a term of five years, wires and gas and water pipes for a term of two years and lighting and certain electrical systems for a period of six months, provided that the properties and such wires, pipes, lighting and systems are used under normal wear and tear conditions. However, such warranties do not cover damages that are the result of improper usage or changes made to the units or equipment by the unit owners or damages that are caused by force majeure. In special circumstances,

however, we may decide to provide free repair services to our customers for damages that are not covered by our warranties. For example, some of our completed properties in Chengdu suffered minor damages such as cracks on the walls during the major earthquake that struck Sichuan province in China in May 2008. While such damages are not covered by our warranties because the earthquake constitutes *force majeure*, we decided to repair such cracks for our customers at our own cost in order to increase our customer satisfaction and enhance our reputation as a responsible property developer.

## Our Property Investment Business

We currently hold certain commercial, industrial and residential units, office spaces, retail shops and car parking spaces, which we consider to be properties held for investment. Such properties are held and managed by us in order to provide us with recurring rental income as well as for capital appreciation potentials. Our investment properties are typically located in prosperous city business areas or areas around city centers as well as in large communities that we develop. In addition, by holding certain properties for lease in the projects that we develop, we believe we have the ability to introduce certain tenants that may potentially increase the attractiveness of our properties. In selecting tenants, we generally consider factors such as the business of the tenant, the attractiveness of such business to the residents or tenants of our properties, competing business in the surrounding area and reputation, among others. The table below sets forth our investment properties as of December 31, 2012:

	<u>Office and Industrial</u>	<u>Residential</u>	<u>Commercial</u>	<u>Car park</u>
	(square meters)	(square meters)	(square meters)	(units)
Total GFA retained for investment . . . . .	65,902	2,652	110,930	6,201

The car parking spaces that we hold for investment in Shenzhen contributed an insignificant portion to our total revenue, during the three-year period ended December 31, 2012.

As additional properties are developed, we will continue to hold a certain percentage of our developed properties as investment properties. However, we may also decide to sell such investment properties from time to time when we believe that such sales would generate a better return on investment than through rental or holding for capital appreciation.

As a result of holding investment properties, our profitability may fluctuate substantially due to changes in fair value of our investment properties because certain portion of our net profits were, during the three-year period ended December 31, 2012, and will continue to be, attributable to changes in the fair value of our investment properties. The fair value of our investment properties is likely to fluctuate from time to time in accordance with local real property market conditions and factors that are beyond our control and may decrease significantly in the future.

## Our Property Operation Business

### *Overview*

Historically, we conducted our property operation business through certain PRC subsidiaries. In early 2011, we commenced to reorganize our property operation business and since then, have been providing property operation services to our properties through the Colour Life Group, in which we own 70% equity interest, with the remaining equity interests owned by the senior management and employees of this business segment. We continue to evaluate our business model and strive to optimize our business portfolio, and may further restructure our property operation business through an initial public offering of the shares of a subsidiary of the Colour Life Group, depending on market conditions. As of the date of this offering memorandum, we are in the process of restructuring Colour Life Group and has in connection therewith, designated our subsidiaries within the Colour Life Group as unrestricted subsidiaries in accordance with the indentures governing the 2010 Notes, the 2012 Notes and the January 2013 Notes. Such restructuring may or may not materialize. Our property operation services business has expanded to cover 24 core cities spanning across China. Property operation services provided include property management services, building equipment installation, maintenance and repair services and

information network services. In addition to servicing properties developed by us, our Group's property operation services are also provided to properties of other developers. Our property operation business also maintains secondary property brokerage services as a value-added service since our disposal of Xingyan Property Consultancy in February 2011. As of December 31, 2012, we had over 5,900 employees for our property operation business. Each operating subsidiary within this business segment has received the relevant certifications and qualifications to provide the respective property operation services.

### ***Property Management Services***

Our property management services are primarily provided by the Colour Life Group and Fantasia Property Management (International) Company Limited. Our Shenzhen Colour Life Services Group Co., Ltd. within the Colour Life Group was recognized as a 2012 Top 100 China Property Management Enterprise (2012中國物業服務百強企業), a recognition that we have received since 2009, as well as a 2011 China Outstanding Property and Service Brand Enterprise (2011中國優秀物業服務品牌企業) from the China Real Estate Top 10 Research Team (中國房地產Top 10研究組). Fantasia Property Management (International) Company Limited is responsible for the high-end property projects of the Group and has obtained ISO9000, ISO14000 and OHSAS18000 integrated system certifications.

We currently provide property management services to properties developed by us as well as properties developed by other developers. We aim to provide the properties that we manage with comprehensive property management services that range from security services, general maintenance of properties and facilities, gardening and other property management services. We also coordinate with the developers, including our property development project companies, to collect customer feedback and address concerns the customers may have as to the development. We typically provide services to other developers under our own brand name.

The typical property management contracts entered into between us and the owners of the properties, including the properties developed by our Group, set out the scope and the quality requirements of the services to be provided by us and the management fee arrangements. Fees are typically fixed at a pre-determined rate within the price range determined by the relevant local authorities that may not be increased without the prior consent of a majority of the owners of the properties. In addition, the contracts also typically allow us to subcontract some of the services, such as security or cleaning services, to third parties. However, under PRC laws and regulations, the home owners of a residential community of certain scale have the right to change property management companies pursuant to certain procedures. See "Risk Factors — Risks Relating to Our Business — Property owners may terminate our engagement as the provider of property management services."

In addition to conventional property management services, we also provide the owners of certain of the properties developed by our Group with daily housekeeping, travel arrangements and other fee-based services that are similar to those offered in hotels.

As we have gained our reputation for providing high quality property management services, other property management companies have retained us to help them improve the property management services they provide to their clients. We receive a consulting fee in return for the advisory services we provide to such third-party property management companies.

The following table sets forth the total GFA managed by us and total GFA in which we provided advisory services as of the dates indicated:

	<b>As of December 31,</b>		
	<b>2010</b>	<b>2011</b>	<b>2012</b>
	<b>(in thousands of square meters)</b>		
GFA under management . . . . .	19,005	32,440	50,310
GFA in which advisory services are provided . . . . .	3,816	4,768	4,460
Total . . . . .	<u>22,821</u>	<u>37,208</u>	<u>54,770</u>

As of December 31, 2012, of the total GFA under management by us, approximately 3.6 million square meters, or 6.5%, were properties developed by us and approximately 51.2 million square meters, or 93.5%, were properties developed by independent third parties. All GFA to which we provide advisory services were properties developed by independent third parties.

In addition, as of December 31, 2012, we entered into contractual arrangements for the management of additional properties with a total GFA of approximately 19.6 million square meters.

#### ***Building Equipment Installation, Maintenance and Repair Services***

Within the Colour Life Group, our PRC subsidiary, Shenzhen Kaiyuan Tongji Building Science & Technology Co., Ltd. (“Shenzhen Kaiyuan”), has the qualifications to engage in the installation, repair and maintenance of building equipment. Shenzhen Kaiyuan currently installs, repairs and maintains certain building equipment of the properties that are managed by us as well as properties developed or managed by others. By having an in-house team of experts who are able to install, repair and maintain building equipment, we believe we are better able to respond to customers’ property servicing needs, reduce building equipment downtime and control installation, maintenance and servicing costs. In addition, by having our own team of experts to provide building equipment installation, maintenance and repair services, we believe we are also better able to control the image and reputation of our properties by being able to respond quickly to repair and maintenance servicing needs as well as strengthen the management services provided by us. Shenzhen Kaiyuan will continue to enhance its expertise and capabilities by servicing more properties as well as by hiring additional personnel when appropriate.

#### ***Information Network Services***

In order to provide a broader range of property operation services, we established a wholly owned subsidiary, Shenzhen Colour Life Network Services Co., Ltd. (“Shenzhen Colour Life Network”) in June 2007, which is aimed at connecting residents or tenants of properties managed by us with third-party vendors through an internally developed internet information platform that provides a variety of value-added services. Such value-added services currently include online ordering for household products, which provide convenience and reduce the costs of household purchases for the residents and tenants due to bulk orders. In addition, we believe such information platform also enhances communication between residents or tenants and the property manager. We aim to continue to improve the information platform and offer additional services such as online payment options or customizable online service orders, as well as integrating its information platform with our own secondary property brokerage information database to provide real estate market information. We believe such large audiences that our information platform reaches will also attract third-party vendors to work with Shenzhen Colour Life Network to provide additional services that will further enhance our offering. Shenzhen Colour Life Network generates revenue through the collection of fees and commissions from vendors that use our information network to offer their products or services.

#### ***Secondary Property Brokerage Services***

We offer advisory services on choices of properties, accompany potential buyers and tenants on house viewing trips, negotiate price and other terms, provide preliminary proof of title, and coordinate with the notary, the bank and the title transfer agency.

Under applicable PRC law, we are permitted to represent both the seller and the purchaser and are entitled to receive up to 1.5% of the transaction value as sales commission from each side in a secondary real estate sales transaction. We typically represent both the seller and the purchaser in our secondary real estate sales transactions in accordance with customary practice in China. For rental units, we typically charge a one-time commission that is equal to 100% of the contracted monthly rent.

## **Our Property Agency Business**

Historically, our Group provided dedicated property agency services through Xingyan Property Consultancy, in which we owned 85% equity interest. Xingyan Property Consultancy offered three principal types of services: (i) primary property agency services that engage in the selling of properties that we develop as well as properties developed by others, (ii) secondary property brokerage services and (iii) property consulting and advisory services. Due to the restructuring of the Group's business and in order for us to focus on our other major business segments, we disposed of our entire 85% interest in Xingyan Property Consultancy in February 2011 to an independent third party. We maintained secondary property brokerage services as a value-added service in our property operation business.

## **Our Hotel Services Business**

We entered into the hotel industry in 2008 with the establishment of our economy hotel, Cai Yue Hotel, in Shenzhen, managed by our subsidiary, Shenzhen Caiyue Hotel Management Co., Ltd. Since then, we have developed several boutique hotels located within our property projects. We have cooperated with well-known international hotel management groups in managing our hotels. For example, in October 2007, we entered into a supporting and consulting services agreement with C.T.E.W. in which C.T.E.W. provided consulting and technical support services in our development of the boutique hotel in Chengdu Hailun Plaza (成都喜年廣場), now named Rhombus Fantasia Chengdu Hotel (花樣年•隆堡成都酒店), as well as a hospitality management contract with Rhombus, a subsidiary of C.T.E.W., for Rhombus to manage the hotel, which began trial operation in March 2012 and commenced formal operation in December 2012. We have also entered into agreements with affiliates of Starwood Hotels & Resorts Worldwide, Inc. in relation to development consulting services, system licensing, and hotel operating services for several of our hotels in development. We believe our cooperation with well-known international hotel management groups will help drive the development of our hotel service operations and help build our own professional hotel management team and professional hotel construction team. We have also established our own hotel management subsidiaries, including Shenzhen Fantasia Hotel management Co., Ltd., to manage certain of our boutique hotels, with a view to build boutique hotel brands with unique characteristics. We have established our private boutique brand of "U" hotels with the commencement of operations of our Shenzhen U Hotel in February 2012, and commenced trial operation of another private label "HYDE" hotel located in Chengdu in January 2013, which is a four-star hotel which offers a full range of business and leisure facilities.

In 2012, Rhombus Fantasia Chengdu Hotel was awarded "Top 10 Newly Opened Hotels in China" (中國十佳最新開業酒店大獎) from the 2012 China Hotel Starlight Awards (中國酒店星光大獎). The brand "U Hotel" was awarded 2012 China Chained Boutique Hotel Brand with the Most Development Potential" (2012年度中國最具發展潛力精品連鎖酒店品牌) at the 9th Golden Pillow Award of China Hotels (中國酒店金枕頭獎).

The table below sets forth certain information relating to our hotels as of December 31, 2012:

Hotel name	City	Positioning	Actual or estimated hotel floor area (square meters)	Actual or estimated number of rooms	Type of premises	Management Company	Operating progress	Actual or estimated commencement date
Cai Yue Hotel . . . . .	Shenzhen	Economy	5,400	108	Leased	Shenzhen Caiyue Hotel Management Company Limited	In operation	June 2008
Yixing Town on the Water Hotel . . . . .	Yixing	Boutique	20,300	232	Self-owned/Leased	Yixing Town on the Water Hotel Management Company Limited	In operation	October 2010
Grande Valley International Country Club . . . . .	Chengdu	Boutique	14,200	141	Leased	Pujiang Grande Valley Hotel Management Company Limited	In operation	April 2011
Rhombus Fantasia Chengdu Hotel . . . . .	Chengdu	Five-star	22,200	185	Self-owned	Rhombus (HK) Management Limited	In operation	December 2011
Shenzhen U Hotel . . . . .	Shenzhen	Boutique	7,200	109	Self-owned	Shenzhen Fantasia Hotel Management Company Limited	In operation	February 2012
Chengdu Laojunshan Mountain Health Care Hotel . . . . .	Chengdu	Boutique	10,800	66	Self-owned	Shenzhen Fantasia Hotel Management Company Limited	In operation	December 2012
Tianjin U Hotel . . . . .	Tianjin	Boutique	9,100	122	Self-owned	Shenzhen Fantasia Hotel Management Company Limited	In development	October 2013
Chengdu U Hotel . . . . .	Chengdu	Boutique	9,200	132	Self-owned	Shenzhen Fantasia Hotel Management Company Limited	In development	November 2013
Four Points by Sheraton Guilin, Lingui (by Sheraton) . . . . .	Guilin	Five-star	30,000	264	Self-owned	Starwood Asia Pacific Hotels & Resort Pte Ltd.	In development	October 2014
Solis Lake Tai, Suzhou . . . . .	Suzhou	Five-star	50,500	250	Self-owned	The Capella Hotel Group Asia	In development	March 2015
Four Points by Sheraton Chengdu, Pujiang Resort (by Sheraton) . . . . .	Chengdu	Five-star	33,000	280	Self-owned	Starwood Asia Pacific Hotels & Resort Pte Ltd.	In development	May 2015
Four Points by Sheraton Chengdu, Hi-Tech Zone (by Sheraton) . . . . .	Chengdu	Five-star	36,000	285	Self-owned	Starwood Asia Pacific Hotels & Resort Pte Ltd.	In development	November 2015
Aloft Hotel Chengdu, Pixian (by Sheraton).	Chengdu	Boutique	20,000	250	Self-owned	Starwood Asia Pacific Hotels & Resort Pte Ltd.	In development	January 2019
Aloft Hotel Chengdu, Wuguiqiao (by Sheraton) . . . . .	Chengdu	Boutique	20,000	250	Self-owned	Starwood Asia Pacific Hotels & Resort Pte Ltd.	In development	January 2019
			287,900	2,674				

## **Properties Used or Occupied by Us**

Our corporate headquarters are located on the 4th, 27th and 28th floor of Block A, Hailrun Complex, #6021 Shennan Boulevard, Shenzhen 518040, with a GFA of approximately 4,080 square meters. Such property is owned by Shenzhen Fantasia Investment Development Co. Limited, a project development company in which we own 100% equity interest. In addition, we currently own and lease a number of other properties that are used as our offices.

As of December 31, 2012, properties owned and used by us had an aggregate GFA of approximately 18,362 square meters and properties that we leased had an aggregate GFA of approximately 7,886 square meters, with an aggregate GFA of approximately 7,686 square meters located in the PRC and an aggregate GFA of approximately 200 square meters located in Hong Kong. We lease such properties primarily as offices of the local branches of our subsidiaries and staff dormitories of our employees.

## **Intellectual Property**

We place significant emphasis on developing our brand image and resort to extensive trademark registrations to protect all aspects of our brand image. We have registered in the PRC and in Hong Kong the trademarks of “花樣年” and “花樣年FANTASIA” to protect our corporate name in Chinese and English. In addition, we have registered trademarks and trademark registration applications in Hong Kong and the PRC that cover the names of our important subsidiaries and property development projects and services.

We have also registered the domain name of *www.cnfantasia.com* for the website of our Group on the Internet.

## **Competition**

There are many property developers that undertake property development projects in the Chengdu-Chongqing Economic Zone, the Pearl River Delta region, the Yangtze River Delta region and the Beijing-Tianjin metropolitan region and elsewhere in the PRC. Our major competitors include large national and regional property developers, including local property developers that focus on one or more of the regions in which we operate. We endeavour to further strengthen our leading position in these regions. Our competitors, however, may have a better track record, greater financial, marketing and land resources, broader name recognition and greater economies of scale than us in the regions where we operate.

We also face competition for our real estate services businesses from other real estate service providers in China as well as certain international real estate service providers. Competition in the real estate services business is rapidly evolving, highly fragmented and competitive, and our competitors and competitive factors differ depending on the type of services provided and the geographic market in which we provide such services. Compared to property development, real estate services businesses require a smaller commitment of capital resources and have a relatively lower barrier of entry. Our competitors may have more experience and resources than we have.

For more information on competition, see “Risk Factors — Risks Relating to Our Business — We face intense competition with respect to our property development business, property operation services business, property agency services business and hotel services business.”



**Insurance**

We do not maintain insurance policies for properties that we have delivered to our customers, nor do we maintain insurance coverage against potential losses or damages with respect to our properties before their delivery to customers. In addition, our contractors typically do not maintain insurance coverage on our properties under construction. Based on industry practice in the PRC, we believe that third-party contractors should bear liabilities from tortious acts or other personal injuries on our project sites, and we do not maintain insurance coverage against such liabilities. The construction companies, however, are responsible for quality and safety control during the course of the construction and are required to maintain accident insurance for their construction workers pursuant to PRC laws and regulations. To help ensure construction quality and safety, we have established a set of standards and specifications to be complied with during the construction process. Furthermore, we engage qualified supervision companies to oversee the construction process. Under PRC laws, the owner or manager of properties under construction bears civil liability for personal injuries arising out of construction work unless the owner or manager can prove that he/she is not at fault. Since we have taken the above steps to prevent construction accidents and personal injuries, we believe that we would generally be able to demonstrate that we were not at fault as the property owner if a personal injury claim is brought against us. To date, we have not experienced any material destruction of or damage to our property developments nor have any material personal injury-related claims been brought against us.

Our directors believe our insurance policies are adequate and in line with the industry practice in the PRC. However, we may not have sufficient insurance coverage for losses, damages and liabilities that may arise in our business operations. See “Risk Factors — Risks Relating to Our Business — We may suffer losses arising from uninsured risks.”

**Employees**

As of December 31, 2012, we had 7,502 full time employees. The following table provides a breakdown of our employees by responsibilities as of December 31, 2012:

Management . . . . .	109
Administration . . . . .	148
Accounting . . . . .	161
Human Resources . . . . .	50
Engineering . . . . .	440
Marketing and Sales . . . . .	82
Property, Hotel and Other Management Services . . .	<u>6,512</u>
<b>Total . . . . .</b>	<b>7,502</b>

The remuneration package of our employees includes salary, bonus and other cash subsidies. In general, we determine employee salaries based on each employee’s qualification, position and seniority. We have designed an annual review system to assess the performance of our employees, which forms the basis of our determination on salary raise, bonus and promotion. We are subject to social insurance contribution plans organized by the PRC local governments. In accordance with the relevant national and local labor and social welfare laws and regulations, we are required to pay on behalf of our employees monthly social insurance premium covering pension insurance, medical insurance, unemployment insurance and housing reserve fund. We believe the salaries and benefits that our employees receive are competitive in comparison with market rates.

Our employees do not negotiate their terms of employment through any labour union or by way of collective bargaining agreements. We believe our relationship with our employees is good. We have not experienced significant labor disputes which adversely affected or are likely to have an adverse effect on our business operations.

## **Environmental Matters**

We are subject to PRC environmental laws and regulations as well as environmental regulations promulgated by local governments. As required by PRC laws and regulations, each project developed by a property developer is required to undergo an environmental impact assessment, and an environmental impact assessment report is required to be submitted to the relevant government authorities for approval before commencement of construction. When there is a material change in respect of the construction site, scale or nature of a given project, a new environmental impact assessment report must be submitted for approval. During the course of construction, the property developer must take measures to prevent air pollution, noise emissions and water and waste discharge. In addition, as we contract our construction works to independent third-party contractors and pursuant to the terms of the construction contracts, the contractors and subcontractors are required to comply with the environmental impact assessment and the conditions of the subsequent approval granted by the relevant government authority. During construction, our project directors and project management teams will supervise the implementation of the environmental protection measures.

In addition, PRC environmental laws and regulations provide that if a construction project includes environmental facilities (including engineering projects, devices, monitors and other facilities that were constructed or equipped in order to prevent pollution and protect the environment), such facilities will have to pass an inspection by the environmental authorities and an approval must be obtained before the environmental facilities can commence operations. If a construction project does not include any environmental facilities, no such approval is required. Our business is of such a nature that we are not required to construct environmental facilities and, therefore no approval in respect of environmental facilities from the environmental authorities is necessary.

We believe that our operations are in compliance with currently applicable national and local environmental and safety laws and regulations in all material respects. See “Risk Factors — Risks Relating to Our Business — We are subject to potential environmental liability that could result in substantial costs.”

## **Health and Safety Matters**

Under PRC laws and regulations, we, as a property developer, have very limited potential liabilities to the workers on and visitors to our construction sites, most of which rest with our contractors. Under the Construction Law of the People’s Republic of China (中華人民共和國建築法), the construction contractor assumes responsibility for the safety of the construction site. The main contractor will take overall responsibility for the site, and the subcontractors are required to comply with the protective measures adopted by the main contractor. Under the Environmental and Hygienic Standards of Construction Work Site (建築工地現場環境和衛生標準), a contractor is required to adopt effective occupational injuries control measures, to provide workers with necessary protective devices, and to offer regular physical examinations and training to workers who are exposed to the risk of occupational injuries. To our knowledge, there has been no material non-compliance with the health and safety laws and regulations by our contractors or subcontractors during the course of their business dealings with the Group. During the earthquake that struck Sichuan province in China in May 2008 and in April 2013, neither our Group nor our contractors suffered any loss of lives or injury to our and their respective employees as a result.

In addition, our project directors and project management teams will engage in a weekly safety inspection to ensure the safety of the work environment of our construction sites.

## **Legal Proceedings**

From time to time we are involved in legal proceedings or disputes in the ordinary course of business including claims relating to our guarantees for mortgage loans provided to our purchasers, contract disputes with our purchasers and suppliers and employment disputes. In the second half of 2012, Shenzhen Buji Water Supplies Co., Ltd. (深圳市布吉供水有限公司) initiated proceedings in Shenzhen Longgang District People's Court against Shenzhen Colour Life Property Management Company Limited, one of our subsidiaries, and its subsidiary in relation to a water supplies contract dispute for a total amount of RMB10.9 million. As of the date of this offering memorandum, the proceeding is still pending.

Save as disclosed above, as of the date of this offering memorandum, we are not aware of any material legal proceedings, claims or disputes currently existing or pending against us. However, we cannot assure you that material legal proceedings, claims or disputes will not arise in the future. See "Risk Factors — Risks Relating to Our Business — We may be involved in legal and other proceedings arising out of our operations from time to time and may incur substantial losses and face significant liabilities as a result."

## REGULATION

### I. LEGAL SUPERVISION RELATING TO THE PROPERTY SECTOR IN THE PRC

#### A. Establishment of a Property Development Enterprise

According to the Law of the People's Republic of China on the Administration of Urban Property (中華人民共和國城市房地產管理法) (the "Urban Property Law") promulgated by the Standing Committee of the National People's Congress on July 5, 1994 and revised in August 2007, a property development enterprise is defined as an enterprise which engages in the development and sale of property for the purpose of making profits. Under the Regulations on Administration of Development of Urban Property (城市房地產開發經營管理條例) (the "Development Regulations") promulgated by the State Council on July 20, 1998, an enterprise which is to engage in development of property shall satisfy the following requirements: (1) its minimum registered capital shall be RMB1 million; and (2) it shall employ at least four full-time professional property/construction technicians and at least two full-time accounting officers, each of whom shall hold relevant qualification certificates. The Development Regulations also stipulate that the local government of a province, autonomous region or municipality directly under the central government may, based on local circumstances, impose more stringent requirements on the amount of registered capital of, and the qualifications of professionals retained by, property development enterprises. The following local regulations apply to our business and operations in the PRC:

- a) The Regulations on Property Developments of Guangdong Province (廣東省房地產開發經營條例) revised by the Standing Committee of Guangdong Provincial People's Congress on September 22, 1997, which stipulate that the self-funded capital of a property development enterprise in the Guangdong Province shall be at least RMB3 million.
- b) The Circular in Respect of the Relevant Rules Governing the Administration of Industrial and Commercial Registration and Qualification of Property Development Entities (關於房地產開發企業工商登記與資質管理有關規定的通知) promulgated by the Construction Bureau of Sichuan Province on September 2, 2004, which states that the minimum registered capital of a property development enterprise shall be RMB5 million.
- c) The Regulations on Property Development Enterprises in Tianjin City (天津市房地產開發企業管理規定) drafted by the Tianjin Construction and Communication Commission and the Tianjin City Administration for Industry and Commerce on December 20, 2010, issued by Tianjin City Government on February 16, 2011 and came into effect on March 1, 2011, which stated that the minimum registered capital of a property development enterprise should be RMB30 million.
- d) The Detailed Rules for the Implementation of the provisions on the Administration of Qualifications of Property Developers of Jiangsu Province (江蘇省實施《房地產開發企業資質管理規定》細則) promulgated by the Construction Bureau of Jiangsu Province on August 6, 2001, which stipulate that the minimum registered capital of a property development enterprise established in Yixing City shall be RMB4 million.
- e) The Forwarding Notice of the Ministry of Construction Regulations regarding the Administration of Qualifications of Property Developers (關於轉發建設部《房地產開發企業資質管理規定》的通知), issued by the Beijing Municipal Commission of Housing and Urban Development Construction on September 4, 2000, which stipulate that the minimum registered capital of a property development enterprise in Beijing shall be RMB10 million.
- f) There is no local regulation for Yunnan Province specifying more stringent requirements on the amount of registered capital and the qualifications of professionals of a property development enterprise.

Pursuant to the Development Regulations, a developer who aims to establish a property development enterprise should apply for registration with the Administration for Industry and Commerce. The property development enterprise must also report its establishment to the property development authority in the location of the registration authority, within 30 days upon the receipt of its Business License (營業執照).

Under the Notice on Adjusting the Portion of Capital Fund for Fixed Assets Investment of Certain Industries (關於調整部分行業固定資產投資項目資本金比例的通知) issued by the State Council on April 26, 2004, the portion of capital funding for property projects (excluding affordable residential housing projects) has been increased from 20% to 35%.

However, on May 25, 2009, the State Council issued the Notice on Adjusting the Minimum Capital Requirement for Fixed Assets Investment (關於調整固定資產投資項目資本金比例的通知) and lowered the minimum capital requirement for projects of affordable residential housing and regular commodity residential houses from 35% to 20% and, for other property projects, to 30%.

## **B. Foreign-invested Property Enterprises**

Under the Foreign Investment Industrial Guidance Catalogue (外商投資產業指導目錄) amended jointly by MOFCOM and the NDRC on December 24, 2011 which took effect from January 30, 2012, foreign investment in enterprises engaged in the development of a whole land lot, the construction and operation of high end hotels, premium office buildings, international conference centers and large theme parks, transactions in the real estate secondary market and real estate intermediary or broker services falls within the category of industries in which foreign investment is restricted, while foreign investment related to other kinds of real estate development falls within the category of industry in which foreign investment is permitted. Pursuant to the Foreign Investment Industrial Guidance Catalogue, the construction and operation of golf courses falls within the industry category in which the entry of foreign capital is prohibited. Xiehe Golf (Shanghai) Company Limited, a domestic company acquired in 2013 by a domestic company established by one of our foreign invested companies, is engaged in the operation of a golf course, the construction and initial operation of which was completed by the original shareholder. Xiehe Golf (Shanghai) Company Limited has completed the registration of changes to its shareholding with the relevant Commerce and Industrial Bureau, however, there are no regulations that definitively stipulate that the acquisition and operation of a domestic company by a second-tier domestic subsidiary of a foreign invested enterprise is subject to the Foreign Investment Industrial Guidance Catalogue.

According to the Interim Provisions on Approving Foreign Investment Projects (外商投資項目核准暫行管理辦法) promulgated by the NDRC in October 2004, the NDRC shall examine and approve foreign investment projects with a total investment of US\$100 million or more that come within the category of industries in which foreign investment is encouraged or permitted and those with a total investment of US\$50 million or more that come within the category of industries in which foreign investment is restricted. Foreign investment projects with a total investment of US\$500 million or more that come within the category of industries in which foreign investment is encouraged or permitted and those with a total investment of US\$100 million or more that come within the category of industries in which foreign investment is restricted are subject to further approval of the State Council based on the examination and approval of the NDRC.

Foreign invested property enterprises can be established in the form of a Sino-foreign equity joint venture, a Sino-foreign cooperative joint venture or a wholly foreign-owned enterprise. Prior to its registration, the enterprise must be approved by the commerce authorities, upon which a Certificate of Approval for a Foreign-Invested Enterprise (外商投資企業批准證書) will be issued.

On July 11, 2006, the MOC, MOFCOM, the NDRC, the PBOC, SAIC and SAFE jointly promulgated the Opinion on Regulating the Access to and Management of Foreign Capital in the Property Market (關於規範房地產市場外資准入和管理的意見) (the "Opinion"). According to the Opinion, the access to and management of foreign capital in the property market must comply with the following requirements:

- a) Foreign entities or individuals who buy property not for their own use in China must apply for the establishment of a foreign-invested enterprise pursuant to the regulations of foreign

investment in property. After obtaining the approvals from relevant authorities and upon completion of the relevant registrations, foreign entities and individuals can then carry on their business pursuant to their approved business scope.

- b) Where the total investment amount of a foreign-invested property development enterprise is US\$10 million or more, its registered capital shall not be less than 50 percent of the total investment amount; where the total investment amount is less than US\$10 million, its registered capital shall follow the requirements of the existing regulations.
- c) The commerce authorities and the Administration for Industry and Commerce are responsible for the approval and registration of a foreign-invested property development enterprise and the issuance to the enterprise of a Certificate of Approval for a Foreign-Invested Enterprise (which is only effective for one year) and the Business License. Upon full payment of the assignment price under a land grant contract, the foreign-invested property development enterprise should apply for the land use rights certificate in respect of the land. With such land use rights certificate, it can obtain a formal Certificate of Approval for a Foreign-Invested Enterprise from the commerce authorities and an updated Business License.
- d) Transfers of projects or shares in foreign-invested property development enterprises or acquisitions of domestic property development enterprises by foreign investors should strictly follow relevant laws, regulations and policies and obtain the relevant approvals. The investor should submit: (1) a written undertaking of fulfillment of the contract for the assignment of State-owned land use rights; (2) a construction land planning permit and construction works planning permit; (3) land use rights certificate; (4) documents evidencing the filing for modification with the construction authorities; and (5) documents evidencing the payment of tax from the relevant tax authorities.
- e) When acquiring a domestic property development enterprise by way of share transfer or otherwise, or purchasing shares from Chinese parties in a Sino-foreign equity joint venture, foreign investors should make proper arrangements for the employees, assume responsibility for the debts of the enterprise and pay the consideration in one single payment with its own capital. Foreign investors with records showing that they have not complied with relevant employment laws, those with unsound financial track records, or those that have not fully satisfied any previous acquisition consideration shall not be allowed to undertake the aforementioned activities.

On August 14, 2006, The General Office of MOFCOM promulgated the Circular on the Thorough Implementation of the Opinion on Regulating the Access to and Management of Foreign Capital in the Property Market (關於貫徹落實《關於規範房地產市場外資准入和管理的意見》的通知) (the “Circular”). The Circular not only reiterates relevant provisions on foreign investment in the real estate industry as prescribed in the Opinion, but also sets forth the definition of Real Estate FIE as a foreign invested enterprise (FIE) which carries out the construction and operation of a variety of buildings such as ordinary residences, apartments and villas, hotels (restaurants), resorts, office buildings, convention centers, commercial facilities, and theme parks, or, undertakes the development of land or a whole land lot in respect of the abovementioned projects.

On September 1, 2006, the MOC and the SAFE jointly issued the Opinions on Regulating the Foreign Exchange Administration of the Real Estate Market (關於規範房地產市場外匯管理有關問題的通知), providing regulations on real estate development enterprises mainly as follows:

- a) For real estate development enterprises, the current account for foreign exchange shall not maintain property purchase payments remitted by residents of Hong Kong, Macau and Taiwan and overseas Chinese expatriates;
- b) Where the registered capital relating to a Real Estate FIE remains unpaid in its entirety, or the state-owned land use rights certificate is yet to be obtained, or the capital fund of development project has not reached 35 percent of the total amount of the project investment, such Real Estate FIE is not permitted to borrow foreign loans from overseas;

- c) Where foreign entities and individuals purport to merge and acquire domestic real estate enterprises by way of share transfer or any other means, acquire a Chinese party's shares within an equity joint venture, such foreign entities and individuals must be capable of making a one-time payment in relation to the transfer consideration, otherwise SAFE shall not process any foreign exchange registration relating to the foreign exchange transaction.

On May 23, 2007, MOFCOM and SAFE promulgated the Circular on Further Strengthening and Regulating the Approval and Supervision of Real Estate Industry with Direct Foreign Investment (關於進一步加強、規範外商直接投資房地產業審批和監管的通知), which stipulates that:

- a) Strict control should be imposed on the acquisition of or investment in domestic real estate enterprises by way of return investment. Foreign investors shall not acquire control of domestic enterprises for the purpose of circumventing the approval procedure related to Real Estate FIE;
- b) In a Real Estate FIE, Chinese parties shall not, explicitly or implicitly provide any warranties with regard to allocating fixed returns to any party;
- c) A Real Estate FIE incorporated upon approval by local approval bodies should be registered with MOFCOM on a timely basis; and
- d) Foreign exchange administration bodies and designated foreign exchange banks shall not process sale and settlement of foreign exchange for capital account items for Real Estate FIEs that fail to complete filing procedures with MOFCOM or to pass joint inspection for foreign invested enterprises.

In addition, according to the Circular on Distribution of the List of the First Group of Foreign-Invested Real Estate Projects Filed with the Ministry of Commerce (關於下發第一批通過商務部備案的外商投資房地產項目名單的通知) promulgated by the General Department of SAFE on July 10, 2007, (1) local branches of SAFE shall not process any foreign debt registration application or conversion of foreign debt for any Real Estate FIE (including in respect of both newly incorporated FIREEs and FIREEs that have registered increased capital contributions) that obtained a Certificate of Approval for a Foreign-Invested Enterprise from local commerce authorities and completed the registration with a MOFCOM on or after June 1, 2007; (2) SAFE branches shall not process foreign exchange registration (or alterations to registration) or, sale and settlement of foreign exchange for capital account items, for any FIREE that has obtained a Certificate of Approval from local commerce authorities, but that has not registered with MOFCOM on or after June 1, 2007.

On July 1, 2008, MOFCOM implemented the Circular on the Proper Handling of the Record Filing for Foreign Investment in the Real Estate Sector (關於做好外商投資房地產業審批工作的通知), delegating provincial-level commerce authorities the authority to register matters concerning foreign investment in real property projects after approving the legality, authenticity and accuracy of the project.

In accordance with a circular promulgated by SAFE in August 2008 with respect to the administration of conversion into Renminbi of foreign exchange capital contributions to foreign invested enterprises (關於完善外商投資企業外匯資本金支付結匯管理有關業務操作問題的通知), unless otherwise permitted by PRC laws or regulations, Renminbi capital converted from foreign exchange capital contributions can only be applied to activities that come within the approved business scope of such foreign invested enterprise and cannot be used for domestic equity investment or acquisition.

On June 10, 2010, MOFCOM issued the Notice Relating to Decentralizing the Examination and Approval Power for Foreign Investment (商務部關於下放外商投資審批權限有關問題的通知), which stipulates that for establishment of an FIE with total investment of not more than USD300 million under the encouraged and permitted categories and USD50 million under the restricted category as specified in the Foreign Investment Industrial Guidance Catalogue, MOFCOM's branches at the provincial level shall be in charge of examination and approval.

On November 22, 2010, the General Office of MOFCOM issued the Notice on Strengthening the Administration of Approval and Record Filing in respect of the Foreign-invested Real Estate Industry (商務部辦公廳關於加強外商投資房地產業審批備案管理的通知) which aimed to implement the relevant rules promulgated by the State Council and to ensure effective control of the real estate industry. MOFCOM addressed the following issues in the notice:

- a) Local departments of commerce shall strengthen supervision on property projects with an inflow of foreign exchange. When reviewing materials on record, local departments of commerce shall focus on reconfirming the integrity and accuracy of documentation relating to land, including materials proving the transfer of land use rights, such as the land use rights transfer contract and the land use rights certificate;
- b) Local departments of commerce shall, together with relevant local authorities, strengthen the supervision on cross-border investment and financing activities to prevent risks arising from the real estate market and control speculative investments. PRC property enterprises established with offshore capital shall not conduct arbitrage activities through the purchase and sale of real estate property which is under construction or completed; and
- c) Local departments of commerce shall further strengthen the approval, supervision and statistics verification of the establishment and/or capital increase of real estate enterprises by way of merger and acquisition, investment by equity and so on.

### **C. Qualifications of a Property Development Enterprise**

#### *(i) Classifications for the qualifications of property development enterprises*

Under the Development Regulations, a property development enterprise must report its establishment to the governing property development authorities in the location of the registration authority within 30 days of receiving its Business License. The property development authorities shall examine applications for classification of a property development enterprise's qualification by considering its assets, professional personnel and industrial achievements. A property development enterprise shall only engage in property development projects that come within the scope of its approved qualification.

Under the Provisions on the Administration of Qualifications of Property Developers (房地產開發企業資質管理規定) (the "Provisions on Administration of Qualifications") promulgated by the MOC and implemented on March 29, 2000, a property development enterprise shall apply for registration of its qualifications. An enterprise may not engage in the development and sale of property without a qualification classification certificate for property development.

In accordance with the Provisions on Administration of Qualifications, qualifications of a property development enterprise are classified into four classes: class 1, class 2, class 3 and class 4. Different classes of qualification shall be examined and approved by corresponding authorities. The class 1 qualifications shall be subject to both preliminary examination by the construction authority under the government of the relevant province, autonomous region or municipality directly under the central government and then final approval of the construction authority under the State Council. Procedures for approval of developers of class 2 or lower shall be formulated by the construction authority under the people's government of the relevant province, autonomous region or municipality directly under the central government. A developer that passes the qualification examination will be issued a qualification certificate of the relevant class by the qualification examination authority. For a newly established property development enterprise, after it reports its establishment to the property development authority, the latter shall issue a Provisional Qualification Certificate to the eligible developer within 30 days. The Provisional Qualification Certificate shall be effective for one year from its issuance and, depending on the actual business situation of the enterprise, may be extended by the property development authority for a period of no longer than two years. A property development enterprise shall apply with the property development authority for qualification classification within one month of expiry of the Provisional Qualification Certificate.



*(ii) The business scope of a property development enterprise*

Under the Provisions on Administration of Qualifications, a developer of any qualification classification may only engage in the development and sale of the property within its approved scope of business and may not engage in business which falls outside the approved scope of its qualification classification. A class 1 property development enterprise may undertake a property development projects throughout the country without any limit on the scale of the project. A property development enterprise of class 2 or lower may undertake a project with a gross floor area of less than 250,000 square meters and the specific scopes of business shall be formulated by the construction authority under the people's government of the relevant province, autonomous region or municipality.

*(iii) The annual inspection of a property development enterprise's qualification*

Pursuant to the Provisions on Administration of Qualifications, the qualification of a property development enterprise shall be inspected annually. The construction authority under the State Council or its authorized institution is responsible for the annual inspection of a class 1 property development enterprise's qualification. Procedures for annual qualification inspection for developers with class 2 or lower qualifications shall be formulated by the construction authority under the people's government of the relevant province, autonomous region or municipality.

**D. Development of a Property Project**

*(i) Land for property development*

Under the Provisional Regulations of the People's Republic of China on the Grant and Transfer of the Land-Use Rights of State-owned Urban Land (中華人民共和國城鎮國有土地使用權出讓和轉讓暫行條例) (the "Provisional Regulations on Grant and Transfer") promulgated by the State Council on May 19, 1990, a system of assignment and transfer of the right to use State-owned land is adopted. A land user shall pay an assignment price to the State as consideration for the grant of the right to use a land site within a certain term, and the land user may transfer, lease out, mortgage or otherwise commercially exploit the land use rights within the term of use. Under the Provisional Regulations on the Grant and Transfer and the Urban Property Law, the land administration authority under the local government of the relevant city or county shall enter into a land grant contract with the land user to provide for the assignment of land use rights. The land user shall pay the assignment price as provided by the assignment contract. After full payment of the assignment price, the land user shall register with the land administration authority and obtain a land use rights certificate which evidences the acquisition of land use rights. The Development Regulations provide that the land use right for a land parcel intended for property development shall be obtained through grant except for land use rights which may be obtained through appropriation pursuant to PRC laws or the stipulations of the State Council.

Under the Rules Regarding the Grant of State-Owned Land Use Rights by Way of Tender, Auction and Listing-for-sale (招標拍賣掛牌出讓國有土地使用權規定) promulgated by the MLR on May 9, 2002, implemented on July 1, 2002, and as amended under the new name of the Rules Regarding the Grant of State-Owned Construction Land Use Rights by way of Tender, Auction and Listing-for-sale (招標拍賣掛牌出讓國有建設用地使用權規定) which took effect from November 1, 2007, land for commercial use, tourism, entertainment and commodity housing development shall be granted by means of tender, public auction or listing-for-sale. A tender of land use rights means the relevant land administration authority (the "assignor") issues a tender announcement inviting individuals, legal persons or other organizations (whether specified or otherwise) to participate in a tender for the land use rights of a particular parcel of land. The land user will be determined according to the results of the tenders. An auction for land use rights is where the assignor issues an auction announcement, and the bidders can at specified time and location openly bid for a parcel of land. A listing-for-sale is where the assignor issues a listing-for-sale announcement specifying the land grant conditions and inviting bidders to list their payment applications at a specified land exchange within a specified period. The procedures

for tender, auction and listing-for-sale may be summarized as follows (for the purpose of the summary, the participant in a tender, auction or listing for sale is referred to as a ‘bidder’):

- a) The land authority under the government of the city and county (the “assignor”) shall announce at least 20 days prior to the day of competitive bidding, public auction or listing-for-sale. The announcement should include basic particulars of the land parcel, qualification requirements for bidders, the methods and criteria for selection of the winning bidder and certain conditions such as the deposit for the bid.
- b) The assignor shall conduct a qualification verification of the bidding applicants and inform the applicants who satisfy the requirements of the announcement to attend the competitive bidding, public auction or listing-for-sale.
- c) After determining the winning bidder by holding a competitive bidding, public auction or listing-for-sale, the assignor and the winning bidder shall then enter into a confirmation. The assignor should refund the other applicants their deposits.
- d) The assignor and the winning bidder shall enter into a contract for the assignment of State owned land use rights at a time and venue set out in the confirmation. The deposit for the bid paid by the winning bidder will be deemed as part of the assignment price for the land use rights.
- e) The winning bidder should apply to register the land registration after paying off the assignment price. The people’s government at the municipality or county level or above should issue the land use rights certificate.

On June 11, 2003, the MLR promulgated the “Regulations on the Grant of State-owned Land Use Rights by Agreement” (協議出讓國有土地使用權規定). According to this regulation, if there is only one entity interested in using the land, the land use rights (excluding land use rights for business purposes including commercial, tourism, entertainment and residential commodity properties) may be assigned by way of agreement. If two or more entities are interested in the land use rights to be assigned, such land use rights shall be granted by means of tender, auction or listing-for-sale.

According to the Notice of the Ministry of Land and Resources on Relevant Issues Concerning the Strengthening of the Examination and Approval of Land Use in Urban Construction (關於加強城市建設用地審查報批工作有關問題的通知) promulgated by the MLR on September 4, 2003, from the day of issuance of the Notice, the assignment of land use rights for luxurious commodity houses shall be stringently controlled, and applications for land use rights for villas are to be stopped. On May 30, 2006, the MLR issued the Urgent Notice on Rigorously Strengthening the Administration of Land (關於當前進一步從嚴土地管理的緊急通知). The Notice stated that land for property development must be granted by competitive bidding, public auction or listing-for-sale; the rules prohibiting development projects for villas should be strictly enforced; and land supply and relevant procedures of land use for villas ceased to have effect from the date of the Notice.

Under the Urgent Notice of Rigorously Strengthening the Administration of the Land, the land authority should rigidly execute the “Model Text of the State-owned Land-Use Rights Grant Contract” and “Model Text of the State-owned Land-Use Rights Grant Supplementary Agreement (for Trial Implementation)” jointly promulgated by the MLR and the SAIC. The documents relating to the assignment of land should specify the requirements for planning, construction and land use such as relevant restrictions on the dwelling size and plot ratio, and the time limit for the commencement and completion of construction. All these should be set forth in the contract for the assignment of the land.

On September 28, 2007 the MLR promulgated the Rules Regarding the Grant of State-Owned Construction Land Use Rights by Way of Tender, Auction and Listing-for-sale (招標拍賣掛牌出讓國有建設用地使用權規定) which came into force on November 1, 2007. The rules stipulate the legal basis, principles, scope, procedures and legal liability arising from and in connection with the assignment of State-owned land use rights by competitive bidding, public auction or listing for sale. The rules clearly state that the grant of land for industrial use must also be by means of competitive bidding, public auction or listing for sale.

The Measures on the Administration of Reserved Land (土地儲備管理辦法), promulgated by the MOF, the PBOC and the MLR on November 19, 2007, define “reserved land” and stipulate the administrative, regulatory and implementing procedures involved with the management, planning, allocation, use, development, capital expenditure and supply of reserved land. Moreover, the measures make it clear that land must be reserved in accordance with corresponding land programs or plans, and that in determining land reserves priority must be given to land included in state inventories which is unused, unoccupied or under utilized.

On May 23, 2012, the MLR and the NDRC jointly issued the Circular on the Distribution of the Catalog for Restricted Land Use Projects (2012 Version) and the Catalog for Prohibited Land Use Projects (2012 Version) (關於發佈實施《限制用地項目目錄(2012年本)》和《禁止用地項目目錄(2012年本)》的通知). In accordance with the circular, the MLR and the NDRC have restricted the area of land that may be granted by local governments for development of housing to seven hectares for small cities and towns, 14 hectares for medium-sized cities and 20 hectares for large cities; projects for the development of villas have been prohibited.

In November 2009, the MLR issued a Circular on the Distribution of the Catalog for Restricted Land Use Projects (2006 Version Supplement) and the Catalog for Prohibited Land Use Projects (2006 Version Supplement) (關於印發《限制用地項目目錄(2006年本增補本)》和《禁止用地項目目錄(2006年本增補本)》的通知) as a supplement to its 2006 version. In this Circular, the MLR has restricted the area of land that may be granted by local governments for development of commodity housing to seven hectares for small cities and towns, 14 hectares for medium-sized cities and 20 hectares for large cities.

In November 2009, the MOF, the MLR, the PBOC, the PRC Ministry of Supervision and the PRC National Audit Office jointly promulgated the Notice on Further Enhancing the Revenue and Expenditure Control over Land Grants (關於進一步加強土地出讓收支管理的通知). The Notice raises the minimum down-payment for land premiums to 50% and requires the land premium to be fully paid within one year after the signing of a contract for the assignment of land, subject to limited exceptions. Any developer defaulting on any such payment may not participate in any new transactions of land grant.

In March 2010, the MLR promulgated the Notification on Emphasizing Relevant Issues Relating to the Supply and Supervision of Land for Real Estate Development (關於加強房地產用地供應和監管的有關問題的通知) (the “Notification”) which adopted measures to improve the regulation of land for real estate development. These include measures to: improve the preparation and implementation of land supply plans; guarantee the supply of land for subsidized community housing developments; improve the regime of public tender, auction and listing-for-sale of land use rights; enhance the supervision on the use of land; disclose to the public information on the supply and assignment of land and the status of the construction project on the land; and conduct special inspections on outstanding problems related to land use.

Pursuant to the Notification, the administrative authorities for land and resources of cities and counties shall establish a regime for developers to report the commencement and completion of construction projects. Under such regime, the developer shall report in writing to the relevant administrative authority for land and resources at the commencement and completion of the construction project. The commencement and completion date of construction set forth in the agreements may be postponed by reporting the reasons for the delay to the respective administrative authority for land and resources no later than 15 days prior to such date. A developer who fails to report accordingly shall be announced to the public and prohibited from participating in any new land grant transactions for a minimum of one year. Additionally, land used for developing subsidized community housing and small-to-medium-size self-use residential commodity housing, as well as for the redevelopment of run-down and substandard housing shall account for not less than 70% of the total land supply for residential property development. The lowest land premium for the assignment of land use rights shall not be lower than 70% of the benchmark price for land of the same grade in the same locality, and the deposit for the participation as a bidder for the land shall not be lower than 20% of the minimum land premium. The contract for the assignment of land shall be executed in writing within ten days after the deal is reached, the down payment of the land assignment price, which shall not be less than 50% of the full land assignment price, shall be paid within one month after the contract for the assignment of land is executed, and the land assignment price shall be paid in full no later than one year after the contract for the

assignment of land is executed. A property development enterprise that defaults on the payment of the land premium, holds idle land, hoards or speculates in land, develops property on the land exceeding its actual development capacity or defaults on the performance of the contract for the assignment of land shall be banned from participating in any transactions for the assignment of land for a specified period.

The National People's Congress adopted the PRC Property Rights Law (中華人民共和國物權法) in March 2007, which became effective on October 1, 2007. According to the Property Rights Law, when the term of the rights to use construction land for residential (but not other) property purposes expires, it will be renewed automatically. The PRC Property Rights Law further widens the scope of assets that can be mortgaged, allowing for any asset associated with property rights to be mortgaged as collateral unless a specific prohibition under another law or regulation applies.

*(ii) Development of a property project*

(a) Commencement of development with respect to a property project and idle land

Under the Urban Property Law, those who have obtained the land use rights by assignment must develop the land in accordance with the use and period of commencement as prescribed by the contract for the assignment of land. According to the Measures on Disposing Idle Land (閒置土地處置辦法) promulgated by the MLR on April 28, 1999, and as amended on June 1, 2012 with effect from July 1, 2012, a parcel of land can be defined as idle land under any of the following circumstances:

- a) the development of and construction on the land have not begun within a period of one year from the date stipulated in the land grant contract or in the "Approval Letter for Land Allocation;" or
- b) the development of and construction on the land has begun, but the area under construction is less than one third of the total area to be developed or the invested amount is less than 25% of the total amount of investment; and the development and construction have been continuously suspended for more than one year.

The municipality or county-level municipality administrative authority shall, with regard to an identified piece of idle land, give notice to the land user containing proposals on dealing with the idle land, including, (1) extending the time period for development and construction (provided that it shall not be longer than one year); (2) changing the use and planning conditions of the land, and require the land user to fulfill the relevant procedures for the new use or planning; (3) arranging for temporary use for a period not longer than two years; (4) reaching a buy-back agreement with the land user; (5) arranging for replacement land for the land user if the delay of construction is due to planning changes by the administrative authority or (6) other measures proposed and implemented by the municipality or county-level administrative authority based on the particular situation.

With respect to land which is obtained by assignment and which is within the scope of city planning, if the construction work has not commenced after one year as of the date stipulated in the assignment contract, a fine for idle land equivalent to 20% of the assignment price may be imposed on the land user. If the construction work has not commenced after two years, the right to use the land may be forfeited to the State without any compensation. However, the above sanctions will not apply when the delay in commencement of construction is caused by force majeure, non-performance by the government, military control, preservation of cultural relics or other acts of government. On September 8, 2007, the MLR promulgated the Notice on Strengthening the Disposal of Idle Land (關於加大閒置土地處置力度的通知) providing that the land subject to transfer shall be made ready for development before its transfer. The notice also prescribed that the State-owned land use rights certificate shall not be issued before the land grant premium has been paid in full, nor shall any certificate be issued separately according to the ratio of part-payment of the land grant premium.

On January 3, 2008, the State Council promulgated the Circular on Conservation of Intensive Land Use (關於促進節約集約用地的通知) (Guo Fa (2008) No. 3), which seeks to:

- a) Examine and adjust all ranges of site planning and land use standards in line with the principle of economic and intensive land use. Project designs, construction and approval of construction shall all be subject to stringent land use standards.

- b) Urge all localities to enforce policies for the disposal of idle land. Where a piece of land has been idle for two full years and may be retrieved unconditionally as statutorily required, such land shall be retrieved and arrangements for its use shall be made; where a piece of land has been idle for one year but less than two years, an idle land charge valued at 20 percent of the land assignment premium shall be levied on the land user.
- c) Vigorously guide the use of unused and abandoned land and encourage the development and utilization of aboveground and underground space.
- d) Strictly implement the tender, auction and listing-for-sale regime for land intended for industrial and business purposes. Where the total land premium is not paid in full in compliance with contractual agreement, the land use certificate shall not be issued, nor shall it be issued in proportion to the ratio between the paid-up land premium and the total land premium.
- e) Make reasonable arrangements on residential land and persist on banning land supply for real estate development projects for villas. Strictly prohibit unauthorized conversion of agricultural land into construction land.
- f) Strengthen supervision and inspection of intensive land use conservation.
- g) Discourage financial institutions from granting loans and providing finance to property development enterprises whose real estate development project is less than one quarter invested, occupies an area less than one third and/or was commenced over one year after the project commencement date, in each case as stipulated in the contract for the assignment of land.

(b) Planning of a property project

According to the Measures for Control and Administration of the Grant and Transfer of the Right to Use Urban State-owned Land (城市國有土地使用權出讓轉讓規劃管理辦法) promulgated by the MOC on December 4, 1992, implemented on January 1, 1993 and amended on January 26, 2011, and the Notice of the Ministry of Construction on Strengthening the Planning Administration of the Grant and Transfer of the Right to Use State-owned Land (建設部關於加強國有土地使用權出讓規劃管理工作的通知) promulgated by the MOC on December 26, 2002, after signing the contract for the assignment of land use rights, a property development enterprise shall apply for a project survey and a construction land planning permit from the city planning authority. After obtaining a construction land planning permit, a property development enterprise shall organize the necessary planning and design work in accordance with planning and design requirements and apply for a construction works planning permit from the city planning authority.

The Urban and Rural Planning Law (城鄉規劃法), promulgated by the Standing Committee of the National People's Congress in October 2007 which became effective in January 2008, provides regulations with respect to the formulation, implementation, modification, control, supervision and related legal liability of measures aimed at curbing problems that may arise as a result of conflicts between city and rural construction developments. The scope of the measures includes the planning, layout and construction of cities, towns with administrative status, market towns and villages. In order to effectively prevent construction that is in breach of rules and regulations, the Urban and Rural Planning Law stipulates that where any construction project is commenced without obtaining Construction Land Planning Permit, or where Construction Land Planning Permit has been obtained but construction has proceeded not in accordance with that permit, the Urban and Rural Planning Department at the county level or above may issue an order to cease construction. In the case that the construction can be remedied to conform to the relevant planning rules, an order can be made to rectify the construction in a prescribed period of time and a fine totaling between 5% to 10% of the total construction cost may be imposed. Where the construction cannot conform to relevant planning rules, an order for its demolition will be issued or, where demolition is not possible, the property and/or illegal income derived from the property will be confiscated and a fine totaling 10% or less of the construction cost will be imposed.

In November 2009, the Ministry of Housing and Urban-Rural Development and the Office of the Leading Group for Addressing Problems Regarding Unauthorized Change of Planning and Adjustment of the Floor Ratio in Real Estate Development under the Ministry of Supervision jointly promulgated the Notification on Further Implementation of the Special Project to Address Problems Regarding Unauthorized Changes to the Planning and Adjustment of the Floor Area Ratio (關於深入推進房地產開發領域違規變更規劃調整容積率問題專項治理的通知) which re-emphasized the need to rectify, investigate and punish property development enterprises which undertake any unauthorized adjustment of the floor area ratio.

(c) Construction of a property project

According to the Measures for the Administration of Construction Permits for Construction Projects (建築工程施工許可管理辦法) promulgated by the MOC on October 15, 1999 and as amended and implemented on July 4, 2001, after obtaining the construction works planning permit, a property development enterprise shall apply for a construction works commencement permit from the construction authority under the local people's government at the county level or above. The Notice Regarding the Strengthening and Regulation of the Management of New Projects (關於加強和規範新開工項目管理的通知), promulgated by the General Office of the State Council on November 17, 2007, strictly regulates the conditions for commencing investment projects, establishes a mechanism for the coordination of government departments regarding new projects, and strengthens the statistics and information management while intensifying the supervision and inspection of new projects.

(d) Completion of a property project

According to the Development Regulations and the Regulation on the Quality Management of Construction Projects (建設工程質量管制條例) promulgated by State Council on January 30, 2000, the Interim Measures for Reporting Details Regarding Acceptance Examination Upon Completion of Buildings and Municipal Infrastructure (房屋建築工程和市政基礎設施工程竣工驗收備案管理暫行辦法) promulgated by the MOC in April 2000 and as amended and issued with the new name the Measures for Reporting Details Regarding Acceptance Examination Upon Completion of Buildings and Municipal Infrastructure (房屋建築和市政基礎設施工程竣工驗收備案管理辦法) on October 19, 2009, and the Interim Provisions on Acceptance Examination Upon Completion of Buildings and Municipal Infrastructure (房屋建築工程和市政基礎設施工程竣工驗收暫行規定) promulgated by the MOC on June 30, 2000, after the completion of construction of a project, the property must undergo inspection and receive relevant approvals from local authorities including planning bureaus and environmental protection authorities. Thereafter, the property development enterprise shall apply for at the property development authority under the people's government at the county level or above for a certificate of completion. Once the examination has been completed, a Record of Acceptance Examination upon Project Completion (項目竣工驗收報告) will be issued.

According to the Notice on Further Strengthening the Quality Supervision and Management of Construction Projects (關於進一步加強建築工程質量監督管理的通知) promulgated by the MOC on April 14, 2009, the legal regulatory framework and the supervision system in respect of quality supervision and completion acceptance examination shall be further improved.

## **E. Transfer and Sale of Property**

(i) *Transfer of property*

According to the Urban Property Law and the "Provisions on Administration of Transfer of Urban Property" (城市房地產轉讓管理規定) promulgated by the MOC on August 7, 1995 and as amended on August 15, 2001, a property owner may sell, bequeath or otherwise legally transfer property to another person or legal entity. When transferring the title to a building, the ownership of the building and the land use rights to the site on which the building is situated are transferred simultaneously. The parties to a transfer shall enter into a property transfer contract in writing and register the transfer with the property administration authority having jurisdiction over the location of the property within 90 days of the execution of the transfer contract.

Where the land use rights were originally obtained by assignment, the real property may only be transferred on the condition that: a) the assignment price has been paid in full for the assignment of the land use rights as provided by the contract for the assignment of the land and a land use rights certificate has been obtained; b) development has been carried out according to the contract for the assignment of the land and, in the case of a project in which buildings are being developed, development representing more than 25% of the total investment has been completed.

If the land use rights were originally obtained by assignment, the term of the land use rights after transfer of the property shall be the remaining portion of the original term provided by the contract for the assignment of the land after deducting the time that has been used by the former land user(s). In the event the transferee intends to change the use of the land provided in the original contract for the assignment of the land, consent shall first be obtained from the original grantor and the planning administration authority under the local government of the relevant city or county and an agreement to amend the assignment contract or a new contract for the assignment of the land shall be signed in order to, amongst other matters, adjust the land use rights assignment price accordingly.

If the land use rights were originally obtained by allocation, transfer of the real property shall be subject to the approval of the government vested with the necessary approval power as required by the State Council. Upon such approval, the transferee shall complete the formalities for transfer of the land use rights, unless the relevant statutes require no transfer formalities, and pay the transfer price according to the relevant statutes.

*(ii) Sale of commodity buildings*

Under the “Regulatory Measures on the Sale of Commodity Buildings” (商品房銷售管理辦法) promulgated by the MOC on April 4, 2001 and implemented on June 1, 2001, sale of commodity buildings can include both pre-completion sales (pre-sale) and post-completion sales.

*(a) Permit for Pre-sale of Commodity Buildings*

According to the Development Regulations and the Measures for Administration of Pre-sale of Commodity Buildings (城市商品房預售管理辦法) (the “Pre-sale Measures”) promulgated by the MOC on November 15, 1994 and as amended on August 15, 2001 and July 20, 2004, the pre-sale of commodity buildings shall be subject to a licensing system, and a property development enterprise intending to sell a commodity building before its completion shall register with the property development authority of the relevant city or county to obtain a pre-sale permit. A commodity building may be sold before completion only if: a) the assignment price has been paid in full for the grant of the land use rights involved and a land use rights certificate has been obtained; b) a construction works planning permit and construction works commencement permit have been obtained; c) the funds invested in the development of the commodity buildings put to pre-sale represent 25% or more of the total investment in the project and the progress of works and the completion and delivery dates have been ascertained; and d) the pre-sale has been registered and a pre-sale permit has been obtained.

In addition, according to the Regulations on the Administration of Pre-sale of Commodity Buildings of Guangdong Province (廣東省商品房預售管理條例) promulgated by the Standing Committee of the Guangdong Provincial People’s Congress on August 22, 1998, as amended on October 14, 2000 and further amended on July 23, 2010 and the Notice on Adjusting the Regulations on the Provision of Images Depicting the Progress of Construction of Pre-Sale Commodity Building Projects in Guangdong Province (廣東省關於調整商品房預售專案工程形象進度條例的通知) issued by Guangdong Provincial Construction Bureau in January 2001, the following conditions shall be fulfilled for pre-sale of commodity buildings in Guangdong: a) a real property development qualification certificate and a Business License have been obtained; b) the grant fees for land use rights have been paid in accordance with the relevant provisions of the land administration department and the land use rights certificate has been obtained; c) a construction works planning permit and a construction works commencement permit have been obtained, and the construction quality and safety monitoring procedures have been performed; d) the schedule for construction and the timetable for completion have been determined; e) the construction of the basic superstructure and the topping-out have been completed in respect of properties of not more than seven stories (including seven stories), and at least two-thirds of the basic superstructure

has been completed in respect of properties of more than seven stories; f) a special property pre-sale account with a commercial bank in the place where the project is located has been opened; g) the pre-sale properties and the land use rights for the project are free from any third party rights; and h) other conditions regulated by laws and regulations.

According to the Rules for the Transfer of Real Estate in the Shenzhen Special Economic Zone (深圳經濟特區房地產轉讓條例) promulgated by the Standing Committee of the Shenzhen Municipal Congress in July 1993 and amended in June 1999, the following conditions shall be fulfilled for the pre-sale of commodity buildings: a) land use rights have been lawfully registered and a real property certificate obtained; b) a construction works planning permit and a construction works commencement permit have been obtained; c) the full assignment price for the land use rights and at least 25 percent of the total project investment of the construction development must have been paid and certified by an accountant; d) the property development enterprise and the financier must have signed an agreement to supervise the receipt of funds from pre-sales; and e) the land use rights must have not been mortgaged or where a mortgage did exist it must have been discharged.

Pursuant to the Implementation Opinion in Respect of Enforcing the Administration of Presales of Urban Commodity Properties (關於加強城市商品房預售管理的實施意見) promulgated by the Construction Commission of Sichuan Province on March 10, 2000, the pre-sale of commodity property in Sichuan Province shall comply with the following conditions: a) all premiums for the assignment of the land use rights (other than land supplied by way of allocation in accordance with the State laws) must have been paid and the land use rights certificate must have been obtained; b) a construction works planning permit must have been obtained; c) for a commodity property project with six stories or less, construction of the foundation and basic superstructure must have been completed; for a non-residential project with six stories or less and a commodity property project with six stories or more, the construction of the foundation and the first story of the basic superstructure must have been completed; and the foundation and the first six stories of the superstructure works of a project without a basement must have been completed; and d) the works schedule and date of completion delivery have been determined.

According to the Tianjin City Administration Rules for Commodity Housing (天津市商品房管理條例) promulgated on October 24, 2002 and effective from December 1, 2002, the sale of commodity housing includes both pre-sales and post-completion sales. Property development enterprises applying for a permit to sell commodity housing must comply with the following conditions: a) attainment of legal person status and the requisite class of qualifications for property development; b) possession of lawful rights to the use of state owned land; c) examination and approval of an investment plan for the construction of commodity housing, a construction engineering plan and a construction license; d) payment of fees for the completion of basic installations in accordance with relevant laws; e) possession of copies of property management plans for which registration has been completed or signed agreements for future property management arrangements; f) certification from government departments that the commodity housing building development has attained requisite image standards; g) provision of a timetable for the progress of construction and the completion date; and h) provision of a sales plan.

According to the Regulations on Administration of Sales of Urban Commodity Buildings in Jiangsu Province (江蘇省城市房地產交易管理條例) promulgated by the Standing Committee of Jiangsu Provincial People's Congress on February 5, 2002 and as amended on August 20, 2004, the following conditions shall be fulfilled for the pre-sale of commodity buildings: (i) the Business License for an enterprise as a legal person and a real property development qualification certificate have been obtained; (ii) the assignment price for the relevant land use rights has been paid in full and a land use rights certificate has been obtained; (iii) a construction works planning permit and a construction works commencement permit have been obtained; (iv) the funds invested in the development of commodity buildings put to presale represent 25% or more of the total investment in the project and the works schedule and the completion and delivery dates have been determined.

According to the Notice on Strengthening the Administration of Permits for the Pre-Sale of Commodity Housing (關於加強商品房預售許可證管理有關問題的通知), issued by the Beijing Municipal Bureau of Land and Resources on June 18, 2004, the following materials must be presented by a property development enterprise when applying for a pre-sale permit: (i) a Business License; (ii) the requisite qualification certificates for the relevant class of property development enterprise; (iii) a land



use rights certificate; (iv) proof of full payment of the land transfer fee; (v) a construction works planning permit issued by the planning authority as well as general layout plans for the project; (vi) a construction works commencement permit; (vii) a copy of the construction contract; (viii) proof from the receiving bank that the funds invested in the development of commodity buildings put to presale represent 25% or more of the total investment in the project; (ix) a pre-sale program as well as building plans for pre-sale commodity units; and (x) certification from a recognized entity that the project complies with relevant standards (where applicable).

According to the Regulations on the Administration of Sales of Urban Commodity Buildings in Yunnan Province (雲南省城市房地產開發交易管理條例), issued by the Standing Committee of Yunnan Province on September 22, 2000, revised on December 2, 2005 and as amended on May 28, 2010, depending on the scale of a construction project, pre-sale permits are issued by the relevant city or county construction administration authority. Funds received through pre-sales must be used for the construction of the project.

(b) Supervision of pre-sale income of commodity buildings

According to the Pre-sale Measures, the income of a property development enterprise from the pre-sale of commodity buildings must be used for the construction of the relevant project. The specific measures for the supervision of the income from the pre-sale of commodity buildings shall be formulated by the relevant property administration authorities.

(c) Conditions of the sale of post-completion commodity buildings

Under the regulatory Measures on the Sale of Commodity Buildings (商品房銷售管理辦法), commodity buildings may be put to post-completion sale only when the following preconditions have been satisfied: a) the property development enterprise shall have a Business License and a qualification certificate of a property development enterprise; b) the enterprise shall obtain a land use rights certificate or other approval documents for land use; c) the enterprise shall have the construction works planning permit and construction works commencement permit; d) the building shall have been completed, inspected and accepted as qualified; e) the relocation of the original residents shall have been completed; f) the provision of essential facilities for supplying water, electricity, heating, gas, communication, etc. shall have been made ready for use, and other essential utilities and public facilities shall have been made ready for use, or a date for their construction and delivery shall have been specified; g) the property management plan shall have been completed.

Before the post-completion sale of a commodity building, a property development enterprise shall submit the Property Development Project Manual and other documents evidencing the satisfaction of preconditions for post-completion sale to the property development authority.

(d) Regulations on transactions of commodity buildings

According to the Development Regulations and the Pre-sale Measures, for the pre-sale of commodity buildings, the developer shall sign a contract on the pre-sale of a commodity building with the purchaser. The developer shall, within 30 days after signing the contract, apply for registration and filing of the pre-sale commodity building with the relevant property administration authorities.

Pursuant to the Circular of the General Office of the State Council on Forwarding the Opinions of the Ministry of Construction and other Departments on Stabilizing House Prices (國務院辦公廳轉發建設部等部門關於做好穩定住房價格工作意見的通知) issued on May 9, 2005:

- a) A buyer of a pre-sold commodity building is prohibited from conducting any further transfer of the commodity building before construction has been completed and a property ownership certificate obtained. If there is a discrepancy in the name of the applicant for property ownership and the name of the advance buyer in the pre-sale contract, the property administration authorities shall not register the application for property ownership.
- b) A real name system is applied for each property purchase transaction and an immediate archival filing network system is in place for pre-sale contracts of commodity buildings.

On July 6, 2006, the MOC, the NDRC and SAIC jointly promulgated the Notice on Reorganizing and Regulating Real Estate Transaction Procedures (關於進一步整頓規範房地產交易秩序的通知), the details of which are as follows:

- a) A property development enterprise may start to sell the commodity buildings within 10 days after receiving a pre-sale permit. Without this permit, the pre-sale of commodity buildings is prohibited, as is the subscription to (including reservation, registration and number selecting) or acceptance of any kind of pre-sale payments.
- b) The property administration authority should establish a network system for pre-sale contracts of commodity buildings. The system should include the location and basic information of the commodity building and the schedule for the sale. The buyer of a pre-sale commodity building is prohibited from conducting any further transfer of the commodity building while it is still under construction.
- c) The pre-sale of commodity buildings must not be advertised without a pre-sale permit.
- d) Property development enterprises with a record of serious irregularity or developers who do not satisfy the requirements of the pre-sale of commodity buildings are not allowed to take part in pre-sale activities.
- e) Property administration authorities should strictly carry out the regulations of the pre-sale registration and apply the real name system for house purchases.

*(iii) Mortgages of Property*

Under the Urban Property Law, the Guarantee Law of the People's Republic of China (中華人民共和國擔保法) promulgated by the Standing Committee of the National People's Congress on June 30, 1995 and implemented on October 1, 1995, and the Measures on the Administration of Mortgages of Property in Urban Areas (城市房地產抵押管理辦法) promulgated by the MOC in May 1997 and as amended on August 15, 2001, when a mortgage is lawfully created on a building, a mortgage shall be simultaneously created on the land use rights of the land on which the building is situated. When the land use rights acquired through means of assignment are being mortgaged, the buildings on the land shall be simultaneously mortgaged. The land use rights of town and village enterprises cannot be mortgaged. When buildings owned by town and village enterprises are mortgaged, the land use rights occupied by the buildings shall at the same time also be mortgaged. The mortgagor and the mortgagee shall sign a mortgage contract in writing. Within 30 days after a property mortgage contract is signed, the parties to the mortgage shall register the mortgage with the property administration authorities at the location where the property is situated. A property mortgage contract shall become effective on the date of registration of the mortgage. If a mortgage is created on property in respect of which a house ownership certificate has been obtained, the registration authority shall make an entry under the "third party rights" item on the original house ownership certificate and then issue a Certificate of Third Party Rights to the mortgagee. If a mortgage is created on the commodity building put to pre-sale or under construction, the registration authority shall record the details on the mortgage contract. If construction of a real property is completed during the term of a mortgage, the parties involved shall re-register the mortgage after the issuance of certificates evidencing the ownership of the property.

*(iv) Leases of buildings*

The Administrative Measures for Commodity House Leasing (商品房屋租賃管理辦法) (the "Leasing Measures"), promulgated by the MOC on December 1, 2010, stipulate that the parties to a housing tenancy shall go through requisite housing tenancy registration formalities with the competent real estate authorities of the municipalities directly under the PRC central government, cities and counties where the housing is located within 30 days after the housing tenancy contract is signed. The relevant real estate authorities are authorized to impose a fine below RMB1,000 on individuals, and a fine from RMB1,000 to RMB10,000 on other violators who are not natural persons and fail to comply with the regulations within the specified time limit. The Leasing Measures came into effect as of February 1, 2011 and replaced the Measures for Administration of Leases of Property in Urban Areas (城市房屋租賃管理辦法).

## F. Property Credit

The PBOC issued the Circular on Further Strengthening the Management of Property Loans (關於進一步加強房地產信貸業務管理的通知) on June 5, 2003 to specify the requirements for banks to provide loans for the purposes of residential development, individual home mortgages and individual commodity buildings as follows:

- a) Property loans by commercial banks to property development enterprises shall be granted only in respect of a particular item of property development rather than to meet cash flow or other financing demands. Loans of any kind must not be granted for projects which do not obtain a land use rights certificate, construction land planning permit, construction works planning permit and construction works commencement permit.
- b) Commercial banks shall not grant loans to property development enterprises to pay off land premiums.
- c) Commercial banks may only provide housing loans to individual buyers when the main structural buildings have been topped out. When a borrower applies for an individual home loan for their first residential unit, the minimum first installment remains unchanged at 20%. In respect of a loan application for any additional purchase of a residential unit(s), the percentage of the first installment shall be increased.

Pursuant to the Guidance on Risk Management of Property Loans from Commercial Banks (商業銀行房地產貸款風險管理指引) issued by the CBRC on September 2, 2004, any property development enterprise applying for property development loans shall have at least 35% of the capital required for the development.

According to the Notice of the People's Bank of China on the Adjustment of Commercial Bank Housing Credit Policies and the Interest Rate of Excess Reserve Deposits (中國人民銀行關於調整商業銀行住房信貸政策和準備金存款利率的通知) promulgated by the PBOC on March 16, 2005, which took effect from March 17, 2005, in cities and areas where there has been a rapid increase in house prices, the minimum first installment for individual house loans increased from 20% to 30%. Commercial banks can independently determine the particular cities or areas under such adjustment according to the specific situation in different cities or areas.

On May 24, 2006, the State Council issued the Opinions of the Ministry of Construction and other Departments on Adjusting the Housing Supply Structure and Stabilizing Housing Prices (關於調整住房供應結構穩定住房價格的意見). The regulations relating to property credit are as follows:

- a) Strict credit conditions shall be imposed on property development enterprises. In order to suppress the ability of property development enterprises to store up land and housing resources, commercial banks shall not provide loans to those property enterprises that fail to meet loan conditions, such as having a project capital of less than 35%. For property development enterprises that have large volumes of idle land and vacant commodity buildings, the commercial banks shall, in light of the principle of prudential operations, be stricter in controlling the renewal of loans or any form of revolving credit. The commercial banks shall not accept any commodity building that has been idle for three or more years as collateral for loans.
- b) From June 1, 2006, the minimum first installment for individual home loans shall not be lower than 30%. However, considering the demands for housing by the medium and low-income population, the purchase of owner occupied housing with a gross floor area of no more than 90 square meters is still subject to the requirement to provide a deposit of 20%.

According to the Circular on Standardizing the Admittance and Administration of Foreign Capital in the Property Market, foreign-invested property enterprises which have not paid up their registered capital, failed to obtain a land use rights certificate, or which have less than 35% of the capital for the project, will be prohibited from obtaining a loan in or outside China, and SAFE shall not approve the registration of foreign loans from such enterprises.

On September 27, 2007, the PBOC and the CBRC issued the Notice on Strengthening the Management of Commercial Real Estate Credit and Loans (關於加強商業性房地產信貸管理的通知) (the “Notice”). The Notice puts forward requirements for the purpose of strengthening processes for loan management, including by means of credit checks, monitoring of real estate loans and risk management, in respect of (i) real estate development, (ii) land reserves, (iii) housing consumption and (iv) the purchase of commercial buildings.

Pursuant to the Notice, commercial banks shall not grant loans in any form, to (i) projects where the capital funds (owner’s equity) constitutes less than 35%, or, projects without a land use rights certificate, construction land planning permit, construction works planning permit and construction works commencement permit; and (ii) property development enterprises that have been hoarding land and housing resources, as detected and verified by land resources departments and construction authorities. Furthermore, commercial banks are not permitted to accept commodity buildings with a vacancy exceeding three years as collateral for a loan, and may not grant property development enterprises any loans for the payment of relevant land assignment premiums.

In respect of loans for individual housing consumption, commercial banks are only permitted to grant housing loans to individuals who purchase commodity buildings the construction of which have reached the “topping out of the main structure” stage. Where an individual purchases his or her first commodity apartment for self residence purpose, (i) of a construction area is below 90 square meters, the minimum first installment shall be fixed at no less than 20%; and (ii) if the construction area is above 90 square meters, the minimum first installment shall be fixed at no less than 30%. Where an individual has purchased a commodity apartment by means of such loan and proceeds to purchase a second (or more) home, the minimum first installment shall be no less than 40% and the interest rate shall not be under 110% of the benchmark interest rate as announced by the PBOC during same period and in same bracket. Further, the minimum first installment and the interest rate shall both rise with the increase in the number of homes purchased, with the increased percentage rates to be determined by commercial banks, at their own discretion, according to principles of loan risk management. However, the monthly repayments for housing loans shall not exceed 50% of the individual borrower’s monthly income.

In respect of commercial building loans, commercial buildings purchased by loan shall be buildings that have satisfied procedural requirements of completion inspection and acceptance. For such purchase, the minimum first installment shall be no less than 50%, the loan term shall not exceed ten years and the interest rate shall not be under 110% of the benchmark interest rate as announced by the PBOC during the same period and in same bracket. Where a loan application is made in the name of a “commercial and residential building,” the minimum first installment shall be no less than 45% and the loan term and interest rate shall be arranged according to relevant regulations.

The Supplemental Notice on Strengthening the Management of Commercial Real Estate Credit and Loans (關於加強商業性房地產信貸管理的補充通知) (the “Supplemental Notice”), jointly issued by the PBOC and the CBRC and dated December 5, 2007, sets forth supplemental requirements in respect of strengthening housing consumption loan management, mainly including the following:

- a) Assess the number(s) of housing loan with the borrower’s family as the basic calculation unit.
- b) Stipulate conditions under which the housing loan policy for first home buyers shall serve as the referential basis for bank loans.
- c) Where a family that has already purchased a commodity apartment via housing provident fund makes a housing-loan application to commercial banks, the requirements set forth in the Notice shall be duly satisfied in accordance with the Notice.

As stipulated in the Supplemental Notice, in the event an applicant is found to have presented false information and certifications, all commercial banks shall deem the loan application unacceptable.

Since the second quarter of 2008, the PRC government has implemented a series of policies intended to strengthen and improve the sound development of the real estate market.

On May 26, 2008, the CBRC issued the Notice on Further Strengthening Risk Management in the Provision of Credit to the Real Estate Market (Yin Jian Fa No.42[2008]) (關於進一步加強房地產行業授信風險管理的通知). To combat property development enterprises who (i) “falsify mortgages” by using forged property sale contracts; (ii) process “falsified down payments” from borrowers by accepting initial repayments in the pre-sale stage, paying for buyers in advance or by other means; or (iii) mislead banks about decisions over the provision of loans by forging their sale performances or house prices as well as other problems arising in the real estate market, the Notice requires each commercial bank to:

- a) strictly follow the policies and conditions related to the provision of loans to individuals;
- b) improve the monitoring of the qualifications of borrowers;
- c) rigorously examine the enterprise credit ratings of property development enterprises; and
- d) upon discovering that a property development enterprise has engaged in the “falsification of mortgages,” “falsification of down payments,” “forgery of house prices” or other such behavior, terminate the individual housing loans or development loans extended to such developer. Property development enterprises suspected of committing such crimes shall be referred to the judicial organs for further investigation.

On October 22, 2008, the People’s Bank of China issued the Circular on the Expansion of the Downward Adjustment Range for Interest Rates of Commercial Individual Mortgage Loans and Related Issues (中國人民銀行關於擴大商業性個人住房貸款利率下浮幅度等有關問題的通知) which decreased the minimum first installment for residential property purchasers to 20% and reduced the minimum mortgage loan rates for such purchases to 70% of the benchmark interest rate starting from October 27, 2008.

On December 20, 2008, the General Office of the State Council issued Several Opinions on Promoting the Sound Development of the Real Estate Market (關於促進房地產市場健康發展的若干意見), which provides the following regarding loans for property businesses:

- a) The purchase of regular commodity houses for residential purposes is to be encouraged. In addition to extending favorable interest rates and loan policies to first time buyers of apartments for self-residential purposes, individuals with an existing home in which the per person floor area is smaller than the local average may buy a second apartment for self residential purposes under favorable loan terms similar to those that apply to first-time buyers. If individuals purchase a second apartment or more for any other purpose, the interest rate shall be determined according to potential risks by commercial banks and based on the benchmark interest rate.
- b) The proper financing requirements for property development enterprises should be adhered to. Commercial banks shall increase credit financing services available to ordinary commercial housing construction projects, provide financial support and other related services to property development enterprises engaged in merger and restructuring activities, and support the approval of bond issuances by property development enterprises.

The State Council issued the Notice on Adjusting the Minimum Capital Requirement for Capital Funding for Fixed Assets Investment (關於調整固定資產投資項目資本金比例的通知) on May 25, 2009, which provides for the reduction of the minimum capital requirement for affordable residential housing projects and regular commodity residential houses from 35% to 20%, and for other property projects to 30%. When providing credit finance support and services, financial institutions shall determine, at their own discretion, whether to grant a loan and the amount of the loan having regard to the minimum capital requirement as determined by the state.

On June 19, 2009, the CBRC issued the Notice on Further Strengthening the Risk Management of Mortgage Loans (Yin Jian Fa No.59[2009]) (關於進一步加強按揭貸款風險管理的通知). With regard to current problems in the real estate market, particularly in the area of mortgage loans such as “falsified mortgages,” “falsified down payments,” “forged house prices” and the relaxed enforcement of criterion for “loans for a second house,” the Notice reiterates the following requirements:

- a) banking institutions shall strictly carry out pre-loan examinations and tighten the criterion for granting a loan in order to prevent the occurrence of such behavior as “falsified mortgages,” “falsified down payments,” and “forged house prices”;
- b) banking institutions shall proceed to focus on supporting the purchase by individuals of their first commodity house for self-residence purposes and shall not circumvent relevant restrictions with regard to the provision of loans for a second (or more) house by claiming that a national network for credit information collection is not available or that cross-regional investigations into the purchaser’s background is difficult or onerous; and
- c) banking institutions are not entitled to decide the criterion for identifying “loans for a second house” or to lower the minimum first installment indirectly by any means.

On April 17, 2010, the State Council issued the Notice on Firmly Preventing Property Prices from Increasing too rapidly in Certain Cities (國務院關於堅決遏制部分房價過快上漲的通知), pursuant to which the State Council raised the minimum first installment for second home purchases to 50% and set a minimum 30% first installment on first homes with a GFA of more than 90 square meters. Further, the notice also stipulates that interest rates for mortgage loans for second homes cannot be lower than 110% of PBOC benchmark lending rate; and Interest rates for mortgage loans and minimum first installments for third or subsequent homes shall be increased substantially.

On September 29, 2010, the PBOC and the CBRC issued the Notice on Relevant Issues Relating to the Improvement of Differential Housing Loan Policy (關於完善差別化住房信貸政策有關問題的通知), which, among other things:

- a) prohibits commercial banks from providing housing mortgages to any members of a family unit purchasing their third or subsequent residential house or non-local residents who fail to provide one year or longer worth of local tax payment certificates or social insurance payment certificates;
- b) prohibits commercial banks from granting or extending loans to property developers that violate laws and regulations such as: (i) holding idle land; (ii) changing the land use; (iii) delaying the commencement and completion of development; and (iv) intentionally holding properties for future sale for the purpose of new property development;
- c) increases the minimum down payment to at least 30% of the purchase price of the property.

#### **G. Insurance of a Property Project**

There are no mandatory provisions in PRC laws, regulations and government rules which require a property development enterprise to take out insurance policies for its property projects. However, PRC commercial banks may require the property development enterprise to purchase insurance if the commercial bank intends to grant a development loan to the property development enterprise.

## **H. Environmental Protection**

Pursuant to the requirements of relevant laws and regulations such as the Appraisal Measures for the Impact on the Environment of the PRC (中華人民共和國環境影響評價法) implemented by the Standing Committee of the National People's Congress in September 2003, and the Regulations Governing Environmental Protection of Construction Projects (建設項目環境保護管理條例) implemented by the State Council in November 1998, property development enterprises and construction enterprises must carry out an appraisal of the impact the construction project will have on the environment. The relevant project shall not commence until approval is obtained from the supervisory body for environmental protection. While the project is in progress, the developer should also comply with the appraisal documents relating to the impact on the environment and implement the environmental protection measures set out in the opinion of the supervisory body for environmental protection. Such measures must be incorporated into the design, construction and operation of the general construction. Upon completion of the project, the developer should apply to the supervisory body for environmental protection for the inspection and acceptance of the completed environmental protection facilities. Only those projects that have been inspected and accepted may go into operation or be available for use.

Pursuant to the Administrative Regulations for the Environmental Protection of Construction Projects (建設項目環境保護管理條例) promulgated by the State Council on November 29, 1998 which took effect from the same day, and the Administrative Measures for the Examination and Approval of Environmental Protection Facilities of Construction Projects (建設專案竣工環境保護驗收管理辦法) promulgated by Ministry of Environmental Protection of the PRC (中華人民共和國環境保護部) on December 27, 2001 which took effect from February 1, 2002 and was revised on December 22, 2010, and the Law of the People's Republic of China on Evaluation of Environmental Effects (中華人民共和國環境影響評價法) promulgated by the Standing Committee of the National People's Congress on October 28, 2002 which took effect from September 1, 2003, enterprises are required to engage institutions with corresponding environmental impact assessment qualifications to provide environmental impact assessment services and reports for submission to the competent environmental protection administrative authorities. Construction work may only be commenced after such an assessment is submitted to and approved by the environmental protection administrative authority. The construction of pollution prevention and control facilities in a construction project must be designed, constructed and commenced simultaneously with the main facility. Provisions on the Graded Examination and Approval of Environmental Impact Assessment Documents of Construction Projects (建設專案環境影響評價檔分級審批規定) promulgated by the Ministry of Environmental Protection of the PRC, which took effect from March 1, 2009 further classified the construction projects whose environmental impact assessment shall be submitted to and approved by the Ministry of Environment and its local counterparts at provincial level. For those approvals made by lower environmental authorities in respect of construction projects that should have been submitted for approval to a higher competent environmental authority, the higher competent authority may revoke the approval made by such lower authority.

## **I. Construction Safety**

Under relevant laws and regulations such as the Laws for Safe Production in the PRC (中華人民共和國安全生產法) promulgated by the Standing Committee of the National People's Congress in November 2002 and as amended on August 27, 2009, and the Regulations of the Construction Safety of Shenzhen Special Economic Zone (深圳經濟特區建設工程施工安全條例) promulgated by the Standing Committee of the People's Congress of Shenzhen in March, 2003 and amended on June 25, 2004, the property development enterprise should apply to the supervisory department on safety for the registration of supervision for work safety in construction before the commencement of construction. Constructions without such registration will not be granted a construction works commencement permit by the supervisory body. Contractors for the construction should establish the objectives and measures for work safety and improve the working environment and conditions of workers in a planned and systematic way. A work safety protection scheme should also be set up to carry out the work safety job responsibility system. At the same time, contractors should adopt corresponding site work safety protective measures according to the work protection requirements in different construction stages and such measures shall comply with the labor safety and hygiene standards of the State.

Under the Construction Law of the People's Republic of China (中華人民共和國建築法) promulgated by the Standing Committee of the National People's Congress on November 1, 1997 and as amended on April 22, 2011, the construction contractor assumes responsibility for the safety of the construction site. The main contractor will take overall responsibility for the site, and the subcontractors are required to comply with the protective measures adopted by the main contractor.

## **J. Major Taxes Applicable to Property Development Enterprises**

### *(i) Income tax*

According to the Income Tax Law of The People's Republic of China for Foreign-invested Enterprises and Foreign Enterprises (中華人民共和國外商投資企業和外商企業所得稅法) which was promulgated by National People's Congress on April 9, 1991 and implemented on July 1, 1991 and its detailed rules promulgated by State Council on June 30, 1991, the income tax on enterprises with foreign investment was computed on the taxable income at the rate of 30%, and local income tax was computed on the taxable income at the rate of 3%.

Pursuant to the Provisional Regulations of the People's Republic of China on Enterprise Income Tax (中華人民共和國企業所得稅暫行條例) issued by the State Council on December 13, 1993 and enforced on January 1, 1994 and the Detailed Implementation Rules on the Provisional Regulations of The People's Republic of China on Enterprise Income Tax (中華人民共和國企業所得稅暫行條例實施細則) issued by the MOF on February 4, 1994, the income tax rate applicable to Chinese enterprises other than foreign-invested enterprises and foreign enterprises was 33%.

According to the PRC Enterprise Income Tax Law (中華人民共和國企業所得稅法) enacted by the National People's Congress on March 16, 2007 and enforced from January 1, 2008 onwards, a unified income tax rate of 25% is applied towards foreign investment and foreign enterprises which have set up institutions or facilities in the PRC as well as PRC enterprises. The Income Tax Law of The People's Republic of China for Foreign-invested Enterprises and Foreign Enterprises (中華人民共和國外商投資企業和外商企業所得稅法) and the Provisional Regulations of the People's Republic of China on Enterprise Income Tax (中華人民共和國企業所得稅暫行條例) were thereby annulled.

The EIT Law also provides a five-year transition period starting from its effective date for those enterprises which were established before the promulgation date of the new tax law and which were entitled to a preferential lower income tax rate under the then effective tax laws or regulations. The income tax rate of such enterprises will gradually be transiting to the uniform tax rate within the transition period in accordance with implementing rules issued by the State Council. On December 26, 2007, the State Council issued the Circular to Implement the Transition Preferential Policies for the Enterprise Income Tax (關於實施企業所得稅過渡優惠政策的通知), under which, for those enterprises then entitled to a preferential income tax rate of 15% and established before March 16, 2007, the transition income tax rate should be 18%, 20%, 22%, 24% and 25% in 2008, 2009, 2010, 2011 and 2012, respectively.

Under the EIT Law, enterprises established outside of China whose "de facto management bodies" are located in China are considered "resident enterprises" and will generally be subject to the unified 25% enterprise income tax rate as to their global income.

According to the Implementation Rules of the PRC on the Enterprise Income Tax Law (中華人民共和國企業所得稅法實施條例) promulgated by the State Council on December 6, 2007 which became effective from January 1, 2008, a reduced income tax rate of 10% is applicable to any dividends payable to non-PRC enterprise investors from FIEs.

According to the Arrangement between the Mainland of China and the Hong Kong Special Administrative Region for the Avoidance of Double Taxation and the Prevention of Fiscal Evasion (內地和香港特別行政區關於對所得避免雙重徵稅和防止偷漏稅的安排) signed on August 21, 2006, or the Avoidance of Double Taxation Agreement, dividend payments to shareholders in Hong Kong would be withheld at a rate of 5% if their investment ratio in invested entities in China is above 25%, or 10% if their investment ratio in invested entities in China is below 25% and certain other conditions are met.



On April 11, 2008, the State Administration of Taxation issued the Notice of Prepayment of Corporate Income Tax of Real Estate Development Enterprises (關於房地產開發企業所得稅預繳問題的通知), requiring real estate developers to prepay enterprise income tax every quarter (or month) according to their current, actual profit. Under this notice, for income generated from pre-sale (before completion of construction) of buildings for residential or commercial use or other kinds, the tax shall be prepaid in the amount of the estimated quarterly or monthly profit calculated on the preset estimated profit rate, which shall be adjusted according to the actual profit after completion of construction of the buildings and settlement of the taxable cost.

*(ii) Business tax*

Pursuant to the Interim Regulations of the People's Republic of China on Business Tax (中華人民共和國營業稅暫行條例) promulgated by the State Council on December 13, 1993, amended on November 5, 2008, and implemented on January 1, 2009, and the Detailed Implementation Rules on the Provisional Regulations of The People's Republic of China on Business Tax (中華人民共和國營業稅暫行條例實施細則) issued by the MOF on December 25, 1993 and amended and implemented on January 1, 2009, the tax rate applicable to the transfer of real properties, their superstructures and attachments is 5%.

In accordance with Notice on the Adjustment of Business Tax for the Transfer of Individual Homes (關於調整個人住房轉讓營業稅政策的通知) promulgated by the MOF and the SAT on December 22, 2009, from January 1, 2010, individuals who purchased their house for self-residential purposes may, five or more years after the purchase, resell their house without paying business tax. Individuals who have owned their self-residential house for less than five years shall pay business tax on the net profit (the difference between the original price and the sales price). Individuals who have purchased their house for any purpose other than self-residential shall, if they have owned it for five years or more, pay business tax on the net profit or, if they have owned it for less than five years, on the full sale price.

*(iii) Land appreciation tax*

According to the requirements of the Provisional Regulations of The People's Republic of China on Land Appreciation Tax (中華人民共和國土地增值稅暫行條例) (the "Land Appreciation Tax Provisional Regulations") which were promulgated on December 13, 1993 and came into effect on January 1, 1994, and the Detailed Implementation Rules on the Provisional Regulations of the People's Republic of China on Land Appreciation Tax (中華人民共和國土地增值稅暫行條例實施細則) (the "Land Appreciation Tax Detailed Implementation Rules") which were promulgated and came into effect on January 27, 1995, any capital-gain from a transfer of property shall be subject to land appreciation tax. Land appreciation tax shall be charged at four levels of progressive rates: 30% for the appreciation amount not exceeding 50% of the sum of deductible items; 40% for the appreciation amount exceeding 50% but not exceeding 100% of the sum of deductible items; 50% for the appreciation amount exceeding 100% but not exceeding 200% of the sum of deductible items; and 60% for the appreciation amount exceeding 200% of the sum of deductible items. Deductible items include the following:

- a) amount paid for obtaining the land use rights;
- b) costs and expenses for the development of the land;
- c) costs and expenses of new buildings and ancillary facilities, or estimated prices of old buildings and constructions;
- d) related tax payable for the transfer of property; and
- e) other deductible items as specified by the MOF.

According to the requirements of the Land Appreciation Tax Provisional Regulations, the Land

Appreciation Tax Detailed Implementation Rules and the Notice on the Levy and Exemption of Land Appreciation Tax for Development and Transfer Contracts signed before January 1, 1994 (關於對1994年1月1日前簽訂開發及轉讓合同的房地產徵免土地增值稅的通知) issued by the MOF and the SAT on January 27, 1995, land appreciation tax shall be exempted under any of the following circumstances:

- a) The construction of ordinary standard residences for sale (i.e. the residences built in accordance with the local standards for residential properties. Deluxe apartments, villas, resorts etc. do not come under the category of ordinary standard residences) where the appreciation amount does not exceed 20% of the sum of deductible items;
- b) property is repossessed according to laws due to the construction requirements of the State;
- c) due to redeployment of work or improvement of living standard, individuals transfer self used residential property, in which they have been living for 5 years or more, subject to tax authorities' approval;
- d) transfers of real properties under property transfer contracts signed before January 1, 1994, regardless of when the properties are transferred;
- e) if the property development contracts were signed before January 1, 1994 or the project proposal has been approved and capital was injected for development in accordance with the conditions agreed, the Land Appreciation Tax shall be exempted if the properties are transferred for the first time within 5 years after January 1, 1994. The date of signing the contract shall be the date of signing the sale and purchase Agreement. The tax-free period may be prolonged subject to the approval of the MOF and the SAT for particular property projects which are approved by the government for the development of the whole lot of land and long-term development and in which the properties are transferred for the first time after the 5-year tax-free period.

On December 24, 1999, the MOF and the SAT issued the Notice in respect of the Extension of the Period for the Land Appreciation Tax Exemption Policy (關於土地增值稅優惠政策延期的通知) which extended the period for the land appreciation tax exemption policy mentioned above to the end of 2000.

After the issuance of the Land Appreciation Tax Provisional Regulations and the Land Appreciation Tax Detailed Implementation Rules, due to the longer period for property development and transfer, many districts, while they were implementing the regulations and rules, did not require property development enterprises to declare and pay the land appreciation tax. Accordingly, the MOF, the SAT, the MOC and the MLR separately and jointly issued several notices to restate the following: after the land grant contracts are signed, the taxpayers should declare the tax to the local tax authorities where the property is located, and pay land appreciation tax in accordance with the amount as calculated by the tax authority. For those who fail to acquire proof of payment or exemption from land appreciation tax from the tax authorities, the property administration authority shall not process the relevant title change procedures, and shall not issue the property title certificate.

The SAT also issued the Notice on the Strict Handling of the Administration of the Collection of Land Appreciation Tax (關於認真做好土地增值稅徵收管理工作的通知) on July 10, 2002 to request local tax authorities to: modify the management system of land appreciation tax collection; build up a sound taxpaying declaration system for land appreciation tax; and modify the methods of pre-levying tax for the pre-sale of properties. The Notice also pointed out that for property development contracts which were signed before January 1, 1994 or where the project proposal has been approved and capital was injected for development, the policy for exemption from land appreciation tax exemption for properties that are transferred for the first time is no longer in effect and the tax shall be levied again. This requirement is restated in the Notice on Strengthening of Administration of the Collection of Land Appreciation Tax (關於加強土地增值稅管理工作的通知) and the Notice on Further Strengthening the Administration of the Collection of Land Appreciation Tax and Land Use Tax in Cities and Towns (關於進一步加強城鎮土地使用稅和土地增值稅徵收管理工作的通知) issued on August 2, 2004 and August

5, 2004, respectively, by SAT. These two Notices also required that system for the declaration of land appreciation tax and the registration of the sources of the land appreciation tax should be further improved.

On March 2, 2006, the MOF and the SAT issued the Notice on Several Points on Land Appreciation Tax (關於土地增值稅若干問題的通知) to clarify relevant issues regarding land appreciation tax as follows:

- a) Standards for the transfer of ordinary standard residential houses. Where any development project includes ordinary residential houses as well as other commercial houses, the amount of land appreciation shall be verified for both commercial and residential houses, respectively. No adjustment shall be retroactively made to any application for tax exemption for ordinary standard residential houses that were filed with the tax authority at the locality of the property prior to March 2, 2006, especially for ordinary standard residential houses which had been exempted from land appreciation tax as according to standards determined by the people's government of a province, autonomous region or municipality directly under the Central Government.
- b) Standards for the collection and settlement of land appreciation tax:
  - (i) All regions shall decide the advance collection rate in a scientific and reasonable manner, and adjust it at a proper time according to the value of the property as well as the market development level within the region and on the basis of the specific housing categories, namely, ordinary standard residential houses, non-ordinary standard residential houses and commercial houses. After a project is completed, the relevant settlement shall be handled in a timely manner, with any overpayment refunded or any underpayment being made up.
  - (ii) As to any tax that fails to be collected in advance within the advance collection term, overdue fines shall be collected as of the day following the expiration of the prescribed advance collection term according to the provisions of relevant tax collection and administration law.
  - (iii) As to any property project that has been completed and has gone through the acceptance procedure, where the floor area of the property as transferred makes up 85% or more of the saleable floor area, the tax authority may require the relevant taxpayer to settle its land appreciation tax obligation for the transferred property according to the proportion between the income as generated from the transfer of property and the amount under the item of deduction. The specific method of settlement shall be prescribed by the local tax authority of a province, autonomous region or municipality directly under the Central Government, or a city under separate state planning.
  - (iv) As to any investment that uses land (property) as payment for the purchase of shares, where an enterprise involved in the investment engages in property development or where any other property development enterprise invests in commercial houses it itself builds, it shall not be governed by the regulation of the interim exemption of land appreciation tax when the property (land) is transferred to the enterprise.

On December 28, 2006, the SAT issued the Notice on the Administration of the Settlement of Land Appreciation Tax of Property Development Enterprises (國家稅務總局關於房地產開發企業土地增值稅清算管理有關問題的通知) which came into effect on February 1, 2007.

Pursuant to the Notice, a property development enterprise shall settle and clear the LAT payment of its development projects that meet certain criteria with the tax authorities in accordance with the applicable LAT rates. The LAT shall be settled for projects approved by the competent authorities; and for projects developed in different stages, the LAT shall be settled in stages. LAT must be settled if (i) the property development project has been completed and fully sold; (ii) the property development enterprise transfers the whole uncompleted development project; or (iii) the land use rights with respect to the

project are transferred. In addition, the relevant tax authorities may require the property development enterprise to settle the LAT if any of the following criteria is met: (i) for completed property development projects, the transferred GFA represents more than 85% of total salable GFA, or the proportion represented is less than 85%, but the remaining salable GFA has been leased out or used by the property development enterprise; (ii) the project has not been completed sold more than three years after obtaining the sale permit or pre-sale permit; (iii) the property development enterprise applies for cancellation of the tax registration without having settled the relevant LAT; or (iv) other conditions stipulated by the tax authorities.

The Notice also indicated that if any of the following circumstances applies to a property development enterprise, the tax authorities shall levy and collect LAT as per a levying rate no lower than the pre-payment rate with reference to the bearing rate of LAT of local enterprises with a similar development scale and income level: (i) failure to maintain account books required by law or administrative regulation; (ii) destroying account books without authorization or refusing to provide taxation information; (iii) the accounts have not been properly maintained or cost materials, income vouchers and cost vouchers are damaged and incomplete, making it difficult to determine transferred income or the amount of deductible items; (iv) failure to go through LAT settlement within the prescribed period, and such failure is not cured within the period required by the relevant tax authorities; (v) the basis for tax calculation as submitted is obviously low without justifiable cause. Local provincial tax authorities can formulate their own implementation rules according to the notice and the local situation.

On May 12, 2009, the SAT issued the Administrative Rules for the Settlement of Land Appreciation Tax (土地增值稅清算管理規程) (the “Settlement Rules”), which became effective on June 1, 2009. The Settlement Rules reiterated the circumstances under which the LAT must be settled, the criteria that are to be met for relevant tax authorities to require the settlement of LAT and the circumstances under which the tax authorities shall levy and collect LAT as prescribed by the Notice. The Settlement Rules further stipulate detailed procedures for the examination and verification of the settlement of LAT to be carried out by relevant tax authorities.

On May 19, 2010, the State Administration of Taxation issued the Circular on Relevant Issues of the Settlement of Land Appreciation Tax (國家稅務總局關於土地增值稅清算有關問題的通知), which details relevant issues concerning income verification about the settlement of land appreciation tax, and the calculation of applicable exemption under certain circumstances.

On May 25, 2010, the State Administration of Taxation promulgated the Notice on Strengthening the Collection of Land Appreciation Tax (國家稅務總局關於加強土地增值稅徵管工作的通知) and imposed further requirements on the collection of LAT. This notice provides that, except for indemnificatory housing, the minimum LAT prepayment rate shall be no less than 2% for properties in the eastern region of the PRC, no less than 1.5% for properties in the central or northeast region of the PRC and no less than 1% for properties in the western region of the PRC. The LAT prepayment rates will be determined by the local authorities based on the different types of properties in the locality.

In accordance with the “Guangdong Regulations on the Levy and Collection of Land Appreciation Tax” (廣東省土地增值稅徵收管理辦法), property development enterprises in Guangdong should calculate the amount of LAT on the basis of the initial capital costing of the project or the overall capital cost of the project. For pre-sales of commodity houses, it is permissible to pay LAT in advance based on a calculation of the price agreed between the parties (as evidenced in the pre-sale contract) and with reference to the construction size of the house. Once the project is completed, an additional payment towards or a partial refund of the original advance payment may be necessary once the amount of LAT is finally determined.

In accordance with the Notice from Shenzhen Local Taxation Bureau in respect of Adjustment regarding the Advanced Levy and Collection Rate of Land Appreciation Tax (深圳市地方稅務局關於調整我市增值稅預徵率的公告), the deemed rate of LAT is 2% for common housing, 4% for villas and 3% for all other types of properties.

In Sichuan, the levy and collection of LAT is governed by the “Sichuan Local Tax Administration Provisional Regulations on the Levy and Collection of Land Appreciation Tax” (四川省地方稅務局土地增值稅徵收管理暫行規定) promulgated on October 16, 1995 and as amended on June 30, 2010. In accordance with the provisional regulations, a person who is engaged in the development and sale of property must pay LAT in advance. LAT shall be levied and collected in advance on income connected with the transfer of properties prior to their completion. Within 90 days of settling accounts after the completion of project, property development enterprises must submit an audit report to the taxation bureau. Upon verification by the taxation bureau of the amount of LAT already paid, a supplemental payment or a partial refund of LAT may be applicable.

According to the “Tianjin Taxation Bureau Notice on Strengthening the Levy and Collection of Land Appreciation Tax” (天津市地方稅務局關於加強天津市土地增值稅徵收管理的公告) promulgated on January 19, 2011, in respect of commodity houses, the rate of LAT is based on different sales prices to restrict the development of high-level houses. A rate of 2% applies to the properties priced at less than or equal to RMB20,000 per square meter, a rate of 3% applies to the properties priced from RMB20,000 to RMB30,000 per square meter, and a rate of 5% applies to properties priced higher than RMB30,000 per square meter.

The Notice on the Administration of the Levy and Collection of Land Appreciation Tax (關於土地增值稅徵收管理有關問題的通知), promulgated by the Beijing Local Taxation Bureau on December 19, 2006, states that as of January 1, 2007, LAT at the flat rate of 1% shall be pre-collected in respect of all revenue received by a property development enterprise from pre-sales and sales of commodity buildings, unless such commodity buildings are government approved low cost housing or fixed price housing.

According to the Notice on Strengthening the Administration of the Levy and Collection of Land Appreciation Tax (關於進一步加強土地增值稅徵收管理有關問題的通知) issued by the Yunnan Provincial Tax Bureau on August 25, 2005, a pilot program for the pre-collection of LAT in Kunming, Zhaotong, Qujing, Wenshan, Chuxiong, Dali, Baoshan and Lincang commenced on July 1, 2005. Ordinary houses are subject to LAT at a rate between 0.5% and 1%; office buildings, commercial spaces, villas, holiday resorts, high-end apartments and other such commodity buildings are subject to LAT at a rate between 1% and 2%; the transfer of land use rights over land for development is subject to LAT at a rate between 1.5% and 3%. Upon the completion of the construction and sales of a particular project, the property development enterprise must apply to the relevant local taxation bureau for a settlement of LAT, at which stage the developer will be liable to pay any amount of outstanding LAT or, as the case may be, entitled to a refund of excess LAT.

On October 22, 2008, the MOF and the SAT issued the Circular on Taxation Policy Adjustment Concerning Real Estate Trading (關於調整房地產交易環節稅收政策的通知) and temporarily exempted the LAT for individuals selling houses starting from November 1, 2008.

*(iv) Deed tax*

Pursuant to the Interim Regulations of the People’s Republic of China on Deed Tax (中華人民共和國契稅暫行條例) promulgated by the State Council on July 7, 1997 and implemented on October 1, 1997, the transferee, whether an individual or otherwise, of the title to a land site or building in the PRC shall be subject to the payment of deed tax. The rate of deed tax is 3% to 5%. The governments of provinces, autonomous regions and municipalities directly under the central government may, within the aforesaid range, determine their effective tax rates. Pursuant to the Implementation Provisions on Deed Tax in Guangdong Province (廣東省契稅實施辦法) promulgated by the People’s Government of Guangdong on June 1, 1998, effective on October 1, 1997, the rate of deed tax within Guangdong is 3%. Pursuant to the Circular on the Adjustment of the Deed Tax Rate (關於調整契稅稅率的通告) promulgated by the Chengdu Financial Bureau and the Chengdu Local Tax Bureau on June 30, 1999, the deed tax rate for Chengdu is 3%. Pursuant to the Tianjin City Implementation Rules on Deed Tax (天津市契稅徵收實施辦法) promulgated by the Tianjin Municipal Government on October 1, 1997, the deed tax rate for Tianjin is 3%. Pursuant to the Implementation Rules of the Interim Regulations of the People’s Republic of China on Deed Tax (江蘇省實施《中華人民共和國契稅暫行條例》辦法) promulgated by the People’s Government of Jiangsu Province on November 20, 1998 and amended on March 20, 2008, the deed tax rate for Yixing City is 4%. According to the Beijing Administrative Rules on

Deed Tax (北京市契稅管理規定), issued by the Beijing Municipal Government on June 27, 2002 and amended on November 27, 2010, a 3% deed tax applies in Beijing. According to the Administrative Rules on Deed Tax in Yunnan Province (雲南省契稅實施辦法), promulgated by the People's Government of Yunnan Province on May 18, 1998 and amended on November 29, 2010, a 3% deed tax is applicable in Yunnan Province.

On September 29, 2010, the Ministry of Finance, the SAT and the MOHURD issued the Notice of Deed Tax on the Adjustment of Real Estate Transactions and Personal Income Tax Preferential Policies (財政部、國家稅務總局、住房和城鄉建設部關於調整房地產交易環節契稅個人所得稅優惠政策的通知), which provides that: (1) first time home buyers who purchase an ordinary residence that is the family's sole property may receive a fifty percent discount on applicable deed tax; deed tax is reduced to 1% for first time buyers who purchase an ordinary residence with less than 90 square meter floor area which is the family's sole property, and (2) tax payers who, within a single twelve month period, purchased and sold a self-owned residential property and then purchased another residential property shall not be eligible for any reduction of exemption of individual income tax.

(v) *Urban land use tax*

Pursuant to the Provisional Regulations of the People's Republic of China Governing Land Use Tax in Urban Areas (中華人民共和國城鎮土地使用稅暫行條例) promulgated by the State Council on September 27, 1988, implemented on November 1, 1988 and amended on December 31, 2006, land use tax in respect of urban land is levied according to the area of relevant land. As of January 1, 2007, the annual tax on every square meter of urban land collected from foreign-invested enterprises shall be between RMB0.6 and RMB30.0.

(vi) *Buildings tax*

Under the Interim Regulations of the People's Republic of China on Building Tax (中華人民共和國房地產稅暫行條例) promulgated by the State Council on September 15, 1986 and implemented on October 1, 1986 and as amended on January 8, 2011, building tax shall be levied at 1.2% if it is calculated on the basis of the residual value of a building, and 12% if it is calculated on the basis of the rental payments for lease of the building.

According to the Circular Concerning the Levy of Building Tax on Foreign Enterprises and Foreigners (關於對外資企業及外籍個人徵收房產稅有關問題的通知) promulgated by the Ministry of Finance on January 12, 2009, and the Circular Concerning the Implementation of the Levy of Building Tax on Foreign-Invested Enterprise and Foreign Individuals (關於做好外資企業及外籍個人房產稅徵管工作的通知) issued by the SAT on January 6, 2009, from January 1, 2009, domestic and foreign-invested enterprises and foreign individuals will all be subject to the Interim Regulations of the People's Republic of China on Building Tax.

On January 27, 2011, the governments of Shanghai and Chongqing issued their respective measures for implementing pilot property tax schemes, which became effective on January 28, 2011. According to the Circular Regarding the Opinion Concerning the Key Issues of Economic Structure Reform in 2012 (轉發關於2012年深化經濟體制改革重點工作意見的通知) issued by the State Council on March 18, 2012, the scope of such pilot property tax schemes shall be expanded to more cities or districts.

(vii) *Stamp duty*

Under the Interim Regulations of the People's Republic of China on Stamp Duty (中華人民共和國印花稅暫行條例) promulgated by the State Council on August 6, 1988 and implemented on October 1, 1988, for property transfer instruments, including those in respect of property ownership transfer, the stamp duty rate shall be 0.05% of the amount stated therein; for permits and certificates relating to rights, including property title certificates and land use rights certificates, stamp duty shall be levied on an item basis of RMB5 per item.

On October 22, 2008, the MOF and the SAT issued the Circular on Taxation Policy Adjustment Concerning Real Estate Trading (關於調整房地產交易環節稅收政策的通知) and temporarily exempted stamp duty for individuals selling or buying houses starting from November 1, 2008.

*(viii) Municipal maintenance tax*

Under the Interim Regulations of the People's Republic of China on Municipal Maintenance Tax (中華人民共和國城市維護建設稅暫行條例) promulgated by the State Council on February 8, 1985, any taxpayer, whether an individual or otherwise, of product tax, value-added tax or business tax shall be required to pay municipal maintenance tax. The tax rate shall be 7% for a taxpayer whose domicile is in an urban area, 5% for a taxpayer whose domicile is in a county or a town, and 1% for a taxpayer whose domicile is not in any urban area or county or town. According to the Notice on Unifying the Municipal Maintenance Tax and Education Surcharge System of Domestic Enterprises, Foreign-Invested Enterprises and Individuals (關於統一內外資企業和個人城市維護建設稅和教育附加制度的通知) issued by the State Council on October 18, 2010, the municipal maintenance tax will become applicable to foreign-invested enterprises as of December 1, 2010.

*(ix) Education surcharge*

Under the Interim Provisions on the Imposition of the Education Surcharge (徵收教育費附加的暫行規定) promulgated by the State Council on April 28, 1986 and as amended on June 7, 1990 and August 20, 2005, a taxpayer, whether an individual or otherwise, of product tax, value-added tax or business tax shall pay an education surcharge, unless such taxpayer is instead required to pay a rural area education surcharge as provided by the Notice of the State Council on Raising Funds for Schools in Rural Areas (國務院關於籌措農村學校辦學經費的通知). According to the Notice on Unifying the Municipal Maintenance Tax and Education Surcharge System of Domestic Enterprises, Foreign-Invested Enterprises and Individuals (關於統一內外資企業和個人城市維護建設稅和教育附加制度的通知) as issued by the State Council on October 18, 2010, the education surcharge will become applicable to foreign-invested enterprises as of December 1, 2010.

**K. Measures on Stabilizing Housing Price**

The General Office of the State Council promulgated the Circular on Duly Stabilizing the Prices of Residential Properties (關於切實穩定住房價格的通知) on March 26, 2005, requiring measures to be taken to restrain housing prices from increasing too fast and to promote the healthy development of the property market. On May 9, 2005, the General Office of the State Council issued the Opinion of the Ministry of Construction and other Departments on Stabilizing the Prices of Residential Properties (關於做好穩定住房價格工作的意見), which provides that:

*(i) Intensifying planning and control and improving the housing supply structure*

Where there is excessive growth in housing prices and insufficient supply of medium to low priced commodity houses and affordable residential housing, housing construction should mainly involve projects for the development of medium to low priced commodity houses and affordable residential houses. The construction of low-density, high-quality houses shall be strictly controlled. With respect to projects for the construction of medium-or-low-price commodity houses, prior to the assignment of land, the municipal planning authority shall, according to control planning, set forth conditions for the plan and design of such elements as height of buildings, plot ratio and green space. The property authority shall, in collaboration with other relevant authorities, set forth requirements such as sale price, type and area. Such conditions and requirements will be set up as preconditions to the assignment of land to ensure an adequate supply of small or medium-sized houses at moderate and low prices. The local government must intensify the supervision of planning permits for property development projects. Housing projects that have not been commenced within two years must be re-examined, and those that turn out to be noncompliant will have their planning permits revoked.

*(ii) Intensifying control over the supply of land and rigorously enforcing the administration of land*

Where there is rapid excessive growth in the price of land for residential use, the proportion of land for residential use to the total land supply should be raised, and the land supply for the construction of regular commodity housing at medium or low prices and affordable residential housing should be increased. Land supply for villa construction shall be continuously suspended, and land supply for high-end housing property construction shall be restricted.

On May 24, 2006, the General Office of the State Council issued the Opinion of the Ministry of Construction and other Departments on Adjusting Housing Supply Structure and Stabilization of Housing Prices (關於調整住房供應結構穩定住房價格的意見). As to the adjustment of housing supply and stabilization of housing prices, the opinion provides that:

- a) Adjustment to the housing supply structure
  - (i) The construction of medium and small-sized regular commodity houses at medium or low prices should be especially developed to satisfy the demands of local residents.
  - (ii) From June 1, 2006, for each and every commodity building newly examined and approved for the commencement of construction, the proportion of the area of housing (including economically affordable housing) with a unit floor area less than 90 square meters must reach 70% of the total development and construction area. In case of adjustment of the above-mentioned proportion, if required in special cases, the municipalities directly under the central government, separately planned cities and provincial capital cities must submit the special request for adjusting proportion to the MOC for approval. The projects that have been examined and approved but have not received a construction works commencement permit shall where necessary adjust the set style of housing according to the above-mentioned requirements.
- b) Adjustment to tax, credit and land policies
  - (i) Commencing June 1, 2006, business tax applicable to the transfer of a residential property by an individual within five years from the date of purchase will be levied on the basis of the full amount of the sale proceeds. For an individual transferring an ordinary residential property five years or more from the date of purchase, business tax will be exempted. For an individual transferring a house other than an ordinary residential house for five years or more from purchasing, the business tax will be levied on the basis of the balance between the income from selling the house and the purchase price;
  - (ii) In order to restrain property development enterprises from purchasing land and buildings with bank credits, any developer applying for loans shall have at least 35% of capital required for the project development. Commercial banks should restrict the grant or extension of revolving credit facilities in any form to property development enterprises with a large amount of idle land and/or vacant commodity buildings. Commodity buildings which are vacant for more than 3 years should not be accepted as a guarantee by the commercial banks;
  - (iii) From June 1, 2006, the first installment of individual house loans should be no less than 30%. When a borrower applies for individual house loans for his own use and the floor area of the unit is less than 90 square meters, the first installment remains at 20%;



- (iv) At least 70% of the land supply for residential property developments must be used for low-to-medium-cost and small to medium-size units and low-cost rental properties. On the basis of the restriction of price and housing style, the land supply shall adopt the method of competitive bidding of land price and housing price to determine the property development enterprise. Land supply for villa construction shall continue to be suspended, and land supply for low-density and large-area housing property construction shall be strictly prohibited;
  - (v) When construction has not yet started one year after the construction commencement date agreed in the land use rights assignment contract has elapsed, charges for idle land should be collected at a higher level; when the construction has not started two years after the construction commencement date agreed in the land use rights assignment contract have elapsed, the right to use land can be taken back without compensation. The land will be regarded as idle land if: the development and construction of the land has started on time, but the developed area is less than one third of the total area to be developed and constructed, or the invested amount is less than 25% of the total amount of investment, and the development and construction has been continuously suspended for no less than one year without approval.
- c) Further rectifying and regulating the property market
- (i) Any project with a Construction Land Planning Permit which has not started construction should be re-evaluated. If the project is not in accordance with the controlling requirements of the plan, especially the requirements of the set style structure, the construction works planning permit, the construction works commencement permit and the pre-sale permit should not be issued. Projects which have been altered or the construction of which have exceeded the provisions shall be disposed of or confiscated according to law.
  - (ii) The property administration authority and the administration of industry and commerce should investigate any illegal conduct such as contract fraud. Illegal conduct involving commodity building pre-completion sales without the necessary conditions should be ordered to stop and punished. With respect to the property enterprises that store up housing and maliciously manipulate and raise housing prices, the competent authorities shall enforce monetary punishment according to laws and regulations, and the responsible persons concerned may have their Business Licenses revoked and/or shall be investigated and prosecuted.

To implement the Opinions on Adjusting the Housing Supply Structure and Stabilizing Housing Prices, the MOC promulgated Certain Opinions Regarding the Implementation of the Ratio Requirement for the Structure of Newly Constructed Residential Units (關於落實新建住房結構比例要求的若干意見) on July 6, 2006 and made supplemental requirements on the proportion of newly built housing structure as follows:

- a) From June 1, 2006, in any city (including counties), housing with a floor area of less than 90 square meters should reach 70% of the total floor area of commercial commodity buildings newly approved or constructed.
- b) The governments should guarantee the conditions of planning and design of newly-built commodity buildings conform to the requirements of structure and proportion. Any digression from the above-mentioned requirements without authorization is forbidden and a construction works planning permit should not be issued by municipal planning and authorities. If there is any noncompliance with the planning permit, a construction works commencement permit should not issued by the construction authority and a permit for pre-sale of commodity buildings should not be issued by property development authority.

According to Several Opinions of the General Office of the State Council on Providing Financial Support for Economic Development (No.126 [2008]) (國務院辦公廳關於當前金融促進經濟發展的若干意見), issued by General Office of the State Council on December 8, 2008, the State Council (i) implemented and promulgated relevant credit policies and measures to support people's purchase of their first ordinary home or improved ordinary home; (ii) provided more credit support for the construction of low rent houses and affordable residential houses and the reconstruction of shed areas for low-income urban residents; and (iii) initiated the pilot operation of real estate trust investment funds to diversify the financing channels of real estate enterprises.

In January 2010, the General Office of the State Council issued a Circular on Facilitating the Stable and Healthy Development of the Property Market 《關於促進房地產市場平穩健康發展的通知》, which adopted a series of measures to strengthen and improve the regulation of the property market, stabilize market expectation and facilitate the stable and healthy development of the property market. These include, among others, measures to increase the supply of affordable housing and ordinary commodity housing, provide reasonable guidance for the purchase of property, restrain speculative investment in property, and strengthen risk prevention and market supervision. Additionally, the Circular explicitly requires a family (including a borrower, his or her spouse and children under 18) who have already entered into a mortgage for the purchase of a house to pay a minimum down payment of 40% of the purchase price of a second or any additional house which they apply to purchase.

On February 15, 2012, the MLR promulgated the Notice on Accomplishment of Real Estate Land Administration and Control in 2012 (《國土資源部關於做好2012年房地產用地管理和調控重點工作的通知》) which requires that the previous real estate market control policy shall be firmly performed and the real estate land supply for residential projects, especially for social security housing projects shall be guaranteed.

On July 19, 2012, the MLR and MOHURD jointly issued the Urgent Notice to Further Tighten Up Real Property Land Administration and Consolidate the Achievement of Macroeconomic Control of the Real Property Market (《關於進一步嚴格房地產用地管理鞏固房地產市場調控成果的緊急通知》) to strengthen the enforcement of macroeconomic policy in the real property market, which requires residential construction projects must commence within one year from the land title delivery date which is stipulated in the land allocation decision or land grant contract and must be completed within three years from the date of commencement.

On September 6, 2012, the Ministry of Land and Resources promulgated the Notice on Strictly Implementation Land Use Standards and Vigorously Promotion Economical and Intensive Land Use (《關於嚴格執行土地使用標準大力促進節約集約用地的通知》), which stipulates, among other things, that: (a) land use standard shall be strictly implemented and continuously improved. For industrial and commercial land transferred through lawful public tender, auction and listing-for-sale, the administration of land and resources of cities and counties shall establish the requirements related to land use standards for the schemes and announcement of land assignment, and include such requirements in assignment contracts and strictly enforce the requirements. Construction lands that are listed in the Catalog for Prohibited Land Use Projects, or that fail to conform to the prescribed conditions in the Catalog for Restricted Land Use Projects (《限制用地項目目錄》), or for which the intensity of investment, floor area ratio, construction coefficient, ratio of green land, or proportion of administrative offices and living facilities land fail to conform to relevant requirements for industrial projects or total area or each functional division area surpasses the required limits or the land area and floor area ratio fails to conform to the conditions of the residential land supply shall not pass the land supply and approval procedures; (b) the format and substantial content of land use standard shall be strictly examined; (c) the implementation of land use standard shall be further supervised and evaluated; and (d) the land use standard training program shall be given to the officials in land and resources authorities, and such the land use standards shall be widely publicized for the purpose of effectuation.

On November 5, 2012, the Ministry of Land and Resources, the Ministry of Finance, PBOC and CBRC jointly promulgated the Notice on Strengthening Land Reserves and Financing Administration (Guotuzi Fa [2012] No. 162) (《關於加強土地儲備與融資管理的通知》(國土資發[2012]162號)) in order to strengthen land bank institution administration, determine the reasonable scale and structure of land bank, strengthen the administration of land pre-development, reservation and protection, and regulate the financing to land reservation and the use of land reservation funds.

On February 20, 2013, the executive meeting of the State Council chaired by Premier Wen Jiabao issued a document emphasizing the strict implementation of tightening measures for the real estate market. The measures include completing a system of responsibility for stabilizing housing prices; restraining purchases of residential housing for investment and speculation purposes; expanding the supply of both ordinary commodity housing and of land; accelerating construction of affordable housing projects; and strengthening market supervision.

On March 1, 2013, the State Council issued the Notice on Continuing Adjustment and Control of Property Markets (《關於繼續做好房地產市場調控工作的通知》) which requires, among other restrictive measures:

- (i) *Improving the responsibility system for stabilizing housing prices.* Municipalities directly under the central government, cities listed on state plans and provincial capitals (excluding Lhasa) must set an annual objective for controlling housing prices and publish annual new commodity housing price control target in the first quarter of the year.
- (ii) *Firmly restraining purchases of residential housing for investment and speculation purposes.* Municipalities directly under the central government, cities listed on state plans and provincial capitals (excluding Lhasa) which have implemented restrictions on the real estate market are required to cover all administrative areas of the cities as restricted areas, and restricted housing shall include new commodity housing and second-hand housing. Non-local residents who possess one or more residential properties and fail to provide one-year or longer tax payment certificates or social insurance payment certificates are to be barred from purchasing any residential properties located in the administrative area. For cities where housing prices are increasing at an excessively high rate, local branches of the PBOC may further raise the down-payment rate and mortgage interest rate for the purchase of a second residential property. In addition, the state will strictly enforce a 20% tax on home sale profits.
- (iii) *Expanding ordinary commodity housing units and increasing the supply of land.* The overall housing land supply in 2013 shall not be lower than the average actual land supply in the past five years. Financial institutions, subject to credit requirements, are to prioritize requests for loans for ordinary commodity housing construction projects in which medium and small housing units constitute 70% or more of the total units in such construction project.

## **II. LEGAL SUPERVISION RELATING TO THE PROPERTY MANAGEMENT SECTOR IN THE PRC**

### **A. Foreign-invested Property Management Enterprises**

According to the Foreign Investment Industrial Guidance Catalogue, property management falls within the category of industries in which foreign investment is permitted. Foreign invested property management enterprises can be set up as a Sino-foreign equity joint venture, Sino-foreign cooperative joint venture or wholly foreign owned enterprise according to the Catalogue and the relevant requirements of the laws and administrative regulations regarding foreign-invested enterprises. Foreign invested property management enterprises should obtain approval from the commercial authority and obtain an Approval Certification for a foreign-invested enterprise before registering with the Administration for Industry and Commerce.

Pursuant to the Circular of the General Office of the State Council on Issues Concerning the Further Regulation and Control of the Real Estate Market (國務院辦公廳關於進一步做好房地產市場調控工作有關問題的通知) dated January 26, 2011, the municipalities directly under the Central Government, cities specially designated in the State plan, provincial cities and the other cities with excessive or rapid rising real estate prices shall implement strict measures with housing-purchase limitation for a specified period of time. As the general rule, (i) individuals who sell their residential property within five years after their purchase of such property will be charged business taxes based on the full amount of the transfer income; (ii) the minimum down payment for second house of residential family using bank loans or housing provident fund loan is raised to 60% with a minimum lending interest rate of 110% of the benchmark rate; (iii) the PRC government will forfeit the land use rights if a developer fails to obtain the construction permit and commence development for more than two years from the commencement date stipulated in the land grant contract; and (iv) municipalities directly under the Central Government, cities specially designated in the State Plan, provincial capitals and cities with high housing prices shall make purchase restrictions for a specified period. In principle, (a) a local residential family that already holds one house or a non-local residential family that is able to provide evidence of local tax or social insurance payment for a required period is limited to purchasing one house (including new commodity residential houses and second hand houses); and (b) a local residential family who holds two or more houses, a non-local residential family that holds one or more houses and a non-local residential family who can not provide the local payment certificates of tax and/or social insurance for a required period shall be suspended from purchasing any other commodity residential houses in the relevant administrative regions.

According to the Regulation on Clearly Marking Price in the Sale of Commodity Houses (商品房銷售明碼標價規定) promulgated by NDRC on March 16, 2011, the sale of commercial houses shall mark prices on a per unit basis, and show to the public the relevant fees which will be charged and the other factors which are in relation to the sale price. A commercial house operator shall not charge any additional fees other than those clearly marked during the property sale. After the price is clearly marked, the developer cannot increase the sale price or charge any other fees.

### **B. The Qualification of a Property Management Enterprise**

According to the Regulation on Property Management (物業管理條例) enacted by the State Council on June 8, 2003, implemented on September 1, 2003 and amended on August 26, 2007, a qualification system for enterprises engaging in property management activities is adopted. According to the Measures for the Administration on Qualifications of Property Management Enterprises (物業管理企業資質管理辦法) enacted by the MOC on March 17, 2004, implemented on May 1, 2004 and amended on November 26, 2007, a newly established property management enterprise shall, within 30 days from the date of receiving its Business License, apply for qualifications to the competent property departments of the people's governments of the municipalities directly under the central government and cities divided into districts in the locality of industry and commerce registration. The departments of qualification examination and approval shall check and issue property management qualification certificates to enterprises meeting conditions for the corresponding qualification class.

According to the Measures for the Administration on Qualifications of Property Management Enterprises, the qualifications of a property management enterprise shall be classified into first, second and third classes. The competent construction department of the State Council shall be responsible for the issuance and administration of the qualification certificate of the first class property management enterprises. The competent construction departments of the people's governments of provinces and autonomous regions shall be responsible for issuance and administration of the qualification certificate of the second class property management enterprises, and the competent property administration departments of the people's governments of municipalities directly under the central government shall be responsible for issuance and administration of the qualification certificate of the second and third class property management enterprises. The competent realty departments of the people's governments of the cities divided into districts shall be responsible for the issuance and administration of the qualification certificate of the third class property management enterprises.

The property management enterprises with the first class qualification may undertake any realty management projects. The property management enterprises with the second class qualification may undertake the realty management business of residential projects of under 300,000 square meters and the non-residential projects of under 80,000 square meters. The property management enterprises with the third class qualification may undertake the realty management business of residential projects under 200,000 square meters and non-residential projects under 50,000 square meters. An annual inspection system on the qualifications of property management enterprises is adopted.

### **C. Appointment of a Property Management Enterprise**

According to the Regulation on Property Management, the general meeting of owners in a property can appoint and dismiss the property management enterprise with affirmative votes of owners holding more than half of the voting rights. Before the formal appointment of a property management enterprise by the general meeting of the owners, a written temporary service contract should be signed by the construction institutions (for example, a property development enterprise) and a property management enterprise.

## **III. LEGAL SUPERVISION RELATING TO REAL ESTATE INTERMEDIARY SERVICES IN THE PRC**

### **A. Foreign Investment in the Real Estate Intermediate Services Sector**

Under the Foreign Investment Industry Guidance Catalogue amended jointly by MOFCOM and the NDRC on December 24, 2011 which took effect from January 30, 2012, transactions in the real estate secondary market and the real estate intermediary or broker companies falls within the category of industries in which foreign investment is subject to restrictions.

The Regulations on Guiding the Orientation of Foreign Investment (指導外商投資方向規定) promulgated by the State Council on February 21, 2002 and effective from April 1, 2002, stipulate that projects with foreign investment that are classified as restricted projects shall be subject to the examination and approval of the corresponding competent departments of the people's governments of the provinces, autonomous regions, municipalities directly under the Central Government and municipalities. At the time of examination and approval, the project must also be reported to the competent departments and administrative authorities at the next highest level. The power to conduct examination and approval for this kind of project may not be granted to any lower level authority.

### **B. Qualifications for the Real Estate Intermediary Services Sector**

The Regulation on the Property Agency Management (房地產經紀管理辦法) promulgated jointly by MOHURD, the NDRC and Ministry of Human Resources and Social Security of the People's Republic of China (MOHRSS) on January 20, 2011 which took effect from April 1, 2011 states that property agencies providing property agency services must have a stipulated amount of qualified brokers.

## **IV. GENERAL LEGAL SUPERVISION IN THE PRC**

### **Remittance of Renminbi into and outside The PRC**

The Renminbi is not a freely convertible currency. The remittance of Renminbi into and outside the PRC is subject to control imposed under PRC law.

#### ***Current Account Items***

Under PRC foreign exchange control regulations, current account item payments include payments for imports and exports of goods and services, payments of income and current transfers into and outside the PRC.

Prior to July 2009, all current account items were required to be settled in foreign currencies. In July 2009, China commenced a pilot scheme pursuant to which Renminbi may be used to settle imports and exports of goods between approved enterprises in five designated cities in the PRC, namely Shanghai, Guangzhou, Dongguan, Shenzhen and Zhuhai, and enterprises in designated offshore jurisdictions such as Hong Kong and Macau. On June 17, 2010, the PRC government promulgated the Notice on Matters Relating to the Expansion of Pilot Areas for RMB Settlement for Cross-border Trade (Yin Fa [2010] No. 186) (《關於擴大跨境貿易人民幣結算試點有關問題的通知》銀發[2010] 186號) (“186 Circular”). According to the 186 Circular, (i) imports and exports of goods and services and other current account items might be settled in Renminbi, (ii) the pilot scheme was expanded to cover 20 provinces and regions including Shandong, Liaoning, Tianjin and Inner Mongolia, and (iii) there was no longer any restriction on the offshore jurisdictions that may participate in the pilot scheme. Accordingly, any enterprises in the designated regions and any offshore enterprises may use Renminbi to settle any current account items between them (except, in the case of payments for exports of goods from the PRC, only approved enterprises in the designated PRC regions may remit the Renminbi).

As a new regulation, the 186 Circular will be subject to interpretation and application by the relevant PRC authorities. Local authorities may adopt different practices in applying the 186 Circular and impose conditions for settlement of current account items.

#### ***Capital Account Items***

Under PRC foreign exchange control regulations, capital account items include cross-border transfers of capital, direct investments, securities investments, derivative products and loans. Capital account payments are generally subject to approval of the relevant PRC authorities.

Capital account items are generally required to be made in foreign currencies. For instance, foreign investors (including any Hong Kong investors) are generally required to make any capital contribution to foreign invested enterprises in a foreign currency in accordance with the terms set out in the relevant joint venture contracts and/or articles of association as approved by the relevant authorities. Foreign invested enterprises or any other relevant PRC parties are also generally required to make capital item payments including proceeds from liquidation, transfer of shares and reduction of capital to foreign investors in a foreign currency. However, cross-border Renminbi direct investments and settlements have been approved on a trial basis by relevant PRC authorities. On February 25, 2011, the MOFCOM promulgated the Notice on Issues Concerning the Administration of Foreign Investment (Shang Zi Han 2011 No. 72) (《商務部關於外商投資管理工作有關問題的通知》商資函[2011] 72號) (“MOFCOM 72 Notice”), which provides that if a foreign investor intends to make investments in the PRC (whether by way of establishing a new enterprise, increasing the registered capital of an existing enterprise, acquiring an onshore enterprise or providing loan facilities) with Renminbi that the foreign investor generated from cross-border trade settlement or lawfully obtained outside the PRC, the MOFCOM’s prior written consent is required. On June 3, 2011, the PBOC issued the Notice on Clarifying Issues Concerning Cross-Border Renminbi Transactions (Yin Fa 2011 No. 145) (《中國人民銀行關於明確跨境人民幣業務相關問題的通知》銀髮[2011] 145號) (“PBOC 145 Notice”), which further provided that, if a foreign investor intends to make direct investment in the PRC with Renminbi, other than the MOFCOM approval,

it shall also apply to the branch offices of the PBOC at the sub-provincial level or above for approval. The PBOC will determine whether to grant such approval on a case by case basis.

On October 12, 2011, the MOFCOM promulgated the MOFCOM Circular to further facilitate Renminbi inbound direct investments by foreign investors. On October 13, 2011, the PBOC promulgated the PBOC Measures to set forth rules for settlements of Renminbi inbound direct investments. The MOFCOM Circular and the PBOC Measures provide more detailed rules for cross-border Renminbi direct investments and settlements, and amend or replace certain provisions set forth in the MOFCOM 72 Notice and the PBOC 145 Notice relating to the case-by-case pilot program.

- The MOFCOM Circular stipulates that: (1) the Scope of “offshore Renminbi” that may be used in cross-border Renminbi direct investments includes (i) Renminbi obtained by foreign investors through Renminbi settlements of cross-border trade, Renminbi profits generated in China and remitted outside of China, and Renminbi obtained through share transfer, capital reduction, liquidation and advance recovery of investment; and (ii) offshore Renminbi funds obtained by foreign investors from other legitimate sources, including without limitation, Renminbi raised through issuance of Renminbi bonds or stocks outside of China; (2) Cross-border Renminbi direct investments and re-investments by foreign-invested enterprises must comply with the relevant PRC laws and regulations on foreign investments. Such transactions must also comply with national industrial policies on foreign investments, and undergo national security reviews on mergers and acquisitions by foreign investors as well as anti-trust reviews. Cross-border Renminbi direct investments in the real estate industry and cross-border Renminbi strategic investments in PRC domestic-listed companies must comply with the administrative regulations on foreign investments in these industries currently in force; (3) Cross-border Renminbi direct investments may not be invested directly or indirectly into negotiable securities or financial derivatives (other than strategic investments in PRC domestic-listed companies that have been approved by relevant authorities), or be used as entrusted loans; and (4) In principle, the approval procedures for cross-border Renminbi direct investments are consistent with the existing approval scheme of foreign direct investments. However, for investments in the amount of RMB300 million or more and investments relating to (i) financial guarantee, finance lease, micro financing, auction and similar businesses, (ii) foreign-invested investment companies, foreign-invested venture capital investment or equity investment enterprises, and (iii) cement, iron and steel, electrolytic aluminum, shipbuilding and similar industries that are subject to macro-control measures, the provincial level counterparts of MOFCOM must submit the application documents to MOFCOM for its review and approval before issuing the official approval.
- The PBOC Measures provides that: (1) After examining the approval or filing documents issued by MOFCOM, its local counterparts or other relevant regulatory authorities in relation to cross-border Renminbi direct investments, domestic banks are permitted to process foreign investors’ request for remittance of offshore Renminbi funds into China. The case-by-case approval procedures required under the PBOC 145 Notice are no longer applicable; (2) With respect to a foreign investor’s application for outbound remittance of Renminbi profits or funds obtained through capital reduction, share transfer, liquidation and advance recovery of investment, domestic banks may process such request upon examining the resolutions approving the distribution of profits, the approval or filing documents of the relevant authorities regarding capital reduction, share transfer, liquidation and advance recovery of investment, and the tax certificates; (3) For the purpose of calculating the total amount of offshore debt, loans denominated in Renminbi and foreign currencies borrowed by foreign-invested enterprises from overseas shareholders and affiliates as well as overseas financial institutions must be aggregated. Foreign-invested enterprises must apply to domestic banks to open a general Renminbi deposit account to deposit Renminbi loans borrowed offshore. With respect to the request of a foreign-invested enterprise to use its onshore Renminbi funds to repay offshore Renminbi loans, domestic banks may process such remittance request after examining the loan contract, the payment order and the tax certificates; and (4) Foreign investors, foreign-invested enterprises or their Chinese shareholders must open Renminbi special purpose accounts to deposit Renminbi funds relating to cross-border Renminbi direct investments, and cash transactions may not be conducted under this type of account.

Further, if any new PRC regulations are promulgated in the future which have the effect of permitting or restricting (as the case may be) the remittance of Renminbi for payment of transactions categorized as capital account items, then such remittances will need to be made subject to the specific requirements or restrictions set out in such rules.



## MANAGEMENT

Our board is responsible and has general powers for the management and conduct of our business. The table below shows certain information in respect of the members of our board:

Name	Age	Position
PAN Jun (潘軍) . . . . .	42	Chairman, executive director and chief executive officer
ZENG Jie, Baby (曾寶寶) . . . . .	42	Executive director
LAM Kam Tong (林錦堂) . . . . .	44	Executive director, chief financial officer and company secretary
ZHOU Jinquan (周錦泉) . . . . .	46	Executive director
HO Man (何敏) . . . . .	43	Independent non-executive director
LIAO Martin Cheung Kong, JP (廖長江) . . . . .	55	Independent non-executive director
HUANG Ming (黃明) . . . . .	48	Independent non-executive director
XU Quan (許權) . . . . .	70	Independent non-executive director

### Directors

#### *Executive Directors*

**Mr. PAN Jun** (潘軍), aged 42, is the chairman of our board, an executive director, chief executive officer, chairman of our Company's nomination committee, and a member of our Company's remuneration committee. He joined our Group in 1999 and is responsible for the overall operation of our Group's projects, the formulation of our development strategies, as well as supervising the project planning, business and operation management of our Group. He is also currently the president of Fantasia Group (China) Company Limited, the general manager of Shenzhen Fantasia Real Estate Group Limited and the director of a number of the Group's subsidiaries. Mr. Pan has over 16 years of experience in the real estate development industry in China and prior to joining our Group, Mr. Pan was the project manager, the manager of the marketing department, the manager of the valuation department and the assistant to the general manager of World Union Real Estate Consultancy (Shenzhen) Ltd. (世聯地產顧問(深圳)有限公司). Mr. Pan obtained a Bachelor's degree in conservancy and hydropower engineering from Chengdu University of Science and Technology (成都科技大學) in 1992 and holds an EMBA degree from Tsinghua University. Mr. Pan is also a registered property valuer in China and a member of the Shenzhen Institution of Real Estate Appraisers (深圳市不動產估價學會).

**Ms. ZENG Jie, Baby** (曾寶寶), aged 42, is an executive director of our Company. She is also a member of our Company's nomination committee. From 1994 to 1996, Ms. Zeng was the general manager of Shenzhen Kingkey Property Development Company Limited (深圳京基房地產開發有限公司). In 1996, Ms. Zeng established Fantasia Group (China) Company Limited. During the period from 2006 to 2011, Ms. Zeng was the chairlady of Fantasia Group (China) Company Limited and Shenzhen Fantasia Real Estate Group Limited. She is one of the controlling shareholders and the largest Shareholder of the Company. Ms. Zeng holds an EMBA degree from Cheung Kong Graduate School of Management (長江商學院).

**Mr. LAM Kam Tong** (林錦堂), aged 44, is an executive director, chief financial officer and company secretary of our Company. Mr. Lam joined our Group in May 2012 and is responsible for investor relation, financial and regulatory related matters of our Group. He is a member of the Hong Kong Institute of Certified Public Accountants and The Association of Chartered Certified Accountants. Mr. Lam received his bachelor of business administration degree from The Chinese University of Hong Kong in July 1991. He has over 14 years of experience in professional auditing as well as extensive experience in the areas of investor relations, auditing, mergers and acquisitions and offshore financing. Mr. Lam is currently an independent non-executive director of both Sheng Yuan Holdings Limited (盛源控股有限公司), a company listed on the Main Board of the Stock Exchange, and Pegasus Entertainment Holdings Limited (天馬娛樂控股有限公司), a company listed on the Growth Enterprise Market of the Stock

Exchange. Before joining our Group, Mr. Lam was an executive director, chief financial officer and company secretary of China Aoyuan Property Group Ltd. (中國奧園地產股份有限公司), a company listed on the Main Board of the Stock Exchange, for over three years and before which Mr. Lam was the company secretary and qualified accountant for Greentown China Holdings Ltd., another company listed on the Main Board of the Stock Exchange.

**Mr. ZHOU Jinquan** (周錦泉), aged 46, is an executive director of our Company. He joined our Group in January 2013 and is responsible for the management of the financial operation business, strategic management department, financial development department and information and data management center of Fantasia Group (China) Company Limited. He is also currently the vice president of Fantasia Group (China) Company Limited. He obtained a Bachelor's degree in Finance and a Master's degree in Finance from Renmin University of China in July 1989 and July 1992, respectively. Before joining the Company, he worked as the deputy president of China Resources Bank of Zhuhai Head Office (珠海華潤銀行總行) from January 2011 to January 2013. He also worked as the deputy president of Guangxi Beibu Gulf Bank Head Office (廣西北部灣銀行總行) from October 2008 to January 2011. He had been the assistant to the president of Guosen Securities Co., Ltd. (國信證券股份有限公司) from June 2004 to October 2008, and the general manager of International Department of Guoyuan Securities Co., Ltd. (國元證券有限公司) from September 2001 to June 2004. He had worked as the deputy general manager of International Department, general manager of Business Department and Institution Department of Industrial and Commercial Bank Co., Ltd., Shenzhen Branch (工商銀行股份有限公司深圳分行) from April 1994 to September 2001, the staff member of General Office of Guangdong Provincial Government Institute of International Economic Technology (廣東省政府辦公廳國際經濟技術研究所) from July 1992 to April 1994, and the staff member of Industrial and Commercial Bank Co., Ltd., Beijing Branch, Haidian Office (工商銀行股份有限公司北京分行海澱分理處) from September 1989 to July 1990.

#### *Independent Non-executive Directors*

**Mr. HO Man** (何敏), aged 43, is an independent non-executive director. He is also the chairman of our Company's audit committee and a member of each of our Company's remuneration committee and nomination committee, respectively. Mr. Ho holds a Master of Science degree in Finance from the London Business School and is a Chartered Financial Analyst and Certified Public Accountant. Mr. Ho has over 15 years of experience in private equity and financial industry. He joined Chepstow Capital Advisers Limited, a HK based mid-market private equity house, as managing director in January 2010 and is responsible for deal sourcing, evaluation and structuring, negotiation, post investment monitoring and realization, with particular emphasis on Hong Kong and the PRC. Prior to this, Mr. Ho joined CLSA Capital Partners (HK) Limited ("CLSA") in August 1997 and until October 2009 was the managing director, head of China Growth and Expansion Capital of CLSA. Mr. Ho was a non-executive director and a member of the audit committee of SCUD Group Limited (飛毛腿集團有限公司), a company listed on the Main Board of the Stock Exchange, and a non-executive director and an audit committee member of Shanghai Tonva Petrochemical Co., Ltd. (上海棟華石油化工有限公司), a company listed on the Growth Enterprise Market of the Stock Exchange, until October 2009.

**Mr. LIAO Martin Cheung Kong, JP** (廖長江), aged 55, is an independent non-executive director. He is also a member of each of our Company's audit committee, remuneration committee and nomination committee, respectively. Mr. Liao was appointed a Justice of the Peace in 2004. He is also an elected Deputy (representing Hong Kong SAR) to the 12th National People's Congress of the People's Republic of China. In Hong Kong, Mr. Liao serves as a member of the Legislative Council of the Hong Kong SAR, Chairman of the Hong Kong Council for Accreditation of Academic and Vocational Qualifications, a Council member and a Court member of the University of Hong Kong and chairman of the Anti-Money Laundering and Counter-Terrorist Financing (Financial Institutions) Review Tribunal. Mr. Liao graduated with a Bachelor of Economic Science (Hons) degree and a Master of Laws degree from University College London. Mr. Liao was Called to the Bar in England and Wales in 1984 and was Called to the Bar in Hong Kong in 1985 and has been a practising barrister in Hong Kong since 1985. Mr. Liao is also an advocate and solicitor admitted to the Supreme Court of Singapore since 1992.

**Mr. HUANG Ming** (黃明), aged 48, is an independent non-executive director. He is also the chairman of the Company's remuneration committee and a member of each of our Company's audit committee and nomination committee, respectively. He has been a Professor of Finance at the Johnson Graduate School of Management at Cornell University since July 2005 and the Head of School of Finance of Shanghai University of Finance & Economics from 2006 to April 2009. Mr. Huang was an Assistant Professor of Finance at Stanford University, Graduate School of Business from 1998 to 2002. Mr. Huang was also the Associate Dean and visiting Professor of Finance and the Professor of Finance at the Cheung Kong Graduate School of Business (長江商學院) from 2004 to 2005 and from 2008 to 2010, respectively. Since July 2010, Mr. Huang has been a Professor of Finance at the China Europe International Business School (中歐國際工商學院). Mr. Huang graduated from Peking University in 1985 majoring in Physics. Mr. Huang then obtained a Ph.D in Physics and a Ph.D in Business from Cornell University and Stanford University, respectively. Mr. Huang is a non-executive director of the Annuity Fund Management Board of China National Petroleum Corporation (中國石油天然氣集團年金理事會) and Yingli Green Energy Holdings Co Ltd (英利綠色能源控股有限公司) since 2007 and 2008, respectively. He has also been appointed as a non-executive director of Qihoo 360 Technology Co. Ltd. (奇虎360科技有限公司), a company listed on the New York Stock Exchange, in 2011.

**Mr. XU Quan** (許權), aged 70, is an independent non-executive director. He is also a member of each of our Company's audit committee, remuneration committee and nomination committee, respectively. Mr. Xu is a qualified real estate senior engineer and real estate valuer. Mr. Xu obtained a Postgraduate Programme Diploma in Shenzhen Real Property from Jinan University (暨南大學) in 1992. In 1993, Mr. Xu was qualified as a real estate senior engineer (房地產高級工程師) and later in 1995, obtained his qualification as an individual member in the Guangdong Real Property Valuer Association (廣東省房地產估價師學會). Since 2003, Mr. Xu has been the Chairman of Shenzhen Real Estate Association (深圳市房地產業協會).

## Senior Management

**Mr. JIAO Chuhua** (焦曙華), aged 43, is the vice president of Fantasia Group (China) Company Limited. Mr. Jiao joined our Group in December 2011 and is responsible for the financing business of our Group. Prior to joining the Group, he was the director of Gaosheng Consultancy Co., Ltd. (高盛顧問有限公司) from 2005 to 2011, the deputy general manager of the asset management and investment department of Kaili Asset Management Co., Ltd. (凱利資產管理有限公司) from 2002 to 2005 and the audit manager of the Anderson HuaQiang CPA accounting firm from 1997 to 2002. Mr. Jiao received a Bachelor's degree in Finance from Jiangxi College of Finance and Economics (Now Jiangxi University of Finance and Economics) (江西財經學院(現江西財經大學)) in 1991.

**Mr. WANG Liang** (王亮) aged 43, is the vice president of Fantasia Group (China) Company Limited. He is also the director and supervisor of a number of the Group's subsidiaries. Mr. Wang joined our Group in April 2006 and is primarily responsible for the hotel, senior housing and health businesses, investment management and internal control of the Group. Prior to joining our Group, he was the director of the financial management department of Huafu HK Co. Limited (香港華孚集團) and the general manager of the financial management department of one of its subsidiaries from 2005 to 2006, the assistant to general manager of the financial management department of Shenzhen Feishang Industry Group Co., Ltd. (深圳市飛尚實業發展(集團)有限公司) in 2005 and the deputy manager of the finance department of Shenzhen Southern Zhongji Containers Manufacture Co. Ltd. (深圳南方中華集裝箱製造有限公司) from 1994 to 2001. Mr. Wang received a Bachelor's degree in business economics from Yangzhou Normal University (揚州師範學院) in 1992.

**Mr. TANG Xue Bin** (唐學斌), aged 45, is the director and general manager of Shenzhen Colour Life Services Group Co, Limited (深圳市彩生活服務集團有限公司) and also a director of certain subsidiaries of our Group. Mr. Tang joined our Group in 2002 and is responsible for the operation of Shenzhen Colour Life Services Group. Prior to joining our Group, he was the deputy general manager of China Overseas Property Management Ltd. (中海物業管理有限公司) from 1997 to 2001. Mr. Tang obtained a Bachelor's degree in industrial electrical automation (工業電氣自動化) from Tongji University (同濟大學) in 1993 and an EMBA degree from China Europe International Business School (中歐國際工商學院) in 2010.

**Mr. LIU Zongbao** (劉宗保), aged 44, is the vice president of Shenzhen Fantasia Real Estate Group Company Limited and is primarily responsible for sales management and products development. He is also the director of certain subsidiaries of our Group. Mr. Liu joined our Group in March 2005 as the general manager of Chengdu Tonghe Real Estate Development Co., Ltd. (“Chengdu Tonghe”) and was responsible for the operation of Chengdu Tonghe. Prior to joining our Group, he was the deputy general manager of Shenzhen Zhonglian Real Estate Development Co., Ltd. (深圳市中聯房地產企業發展有限公司) from 2004 to 2005 and the manager of the marketing and sales department of Shenzhen Xinghe Real Estate Development Co., Ltd. (深圳市星河房地產開發公司) from 2001 to 2003. Mr. Liu received his Bachelor’s degree in construction management engineering from Southeast University (東南大學) in 1991.

**Ms. LI Chuanyu** (李傳玉), aged 45, is the vice president of Shenzhen Fantasia Real Estate Group Limited. Ms. Li joined our Group in May 2001 and is responsible for financial management. She was the chief financial officer of Shenzhen Huiheng Property Company Limited (深圳市匯恒置業有限公司), the chief financial officer and the general manager of the financial management department of Fantasia Property Group Limited from 2001 to 2011. Prior to joining the Group, she was the deputy general manager of the financial department of Shenzhen Zhujiang Industry Company (深圳珠江實業公司) from 1996 to 2001. Ms. Li received a Master’s degree in international accounting (國際會計) from the City University of Hong Kong (香港城市大學) in 2006.

**Mr. ZHU Xuan** (朱宣), aged 44, is the vice president of Shenzhen Fantasia Real Estate Group Limited. Mr. Zhu joined our Group in March 2013 and is responsible for our Group’s hotel construction management. Prior to joining our Group, he was a vice president of Yanhai Real Estate Investment (China) Company Limited (沿海地產投資(中國)有限公司) from 2012 to March 2013, general manager of Zhonghui Xiyuan Group Construction Design Centre (中惠熙元集團工程設計中心) and director of its district office in Guangzhou from 2010 to 2012, chief architect of Shenzhen Excellence Property Group Limited (深圳卓越置業集團公司) and assistant to general manager of its Shenzhen office from 2006 to 2009, deputy general manager and general engineer of Suzhou Youngor Property Company Limited (蘇州雅戈爾置業公司) from 2005 to 2006, director and general manager of Bowen Environmental Arts Design Company Limited (博聞環境藝術設計公司) from 2002 to 2005, senior manager of the general construction and innovation enhancement centre of Rongkezhidi Real Estate Development Company Limited (融科智地房地產開發有限公司) under the Lenovo Group (聯想集團) from 1998 to 2002, general engineer of Jianyi Decoration Design Construction Company Limited (建藝裝飾設計工程有限公司) from 1995 to 1998, and manager of the design department of Shenzhen Huahui Decoration Design Construction Company Limited (深圳華輝裝飾設計工程有限公司) from 1991 to 1993. Mr. Zhu received a Bachelor’s degree in architecture from South China University of Technology (華南理工大學) in 1991.

**Mr. JIN Jianglin** (金江林), aged 48, is the general manager of Dongguan Fantasia Real Estate Investment Company Limited and is also a director of certain subsidiaries of our Group. Mr. Jin joined our Group in February 2001 and is currently responsible for the operation of Dongguan Fantasia Real Estate Investment Company Limited. From 2001 to 2006, he was the manager of the engineering division, manager of the business division and an assistant to the general manager of Shenzhen Fantasia Investment Development Co., Ltd. Prior to joining our Group, he was a chief supervisor of Shenzhen Huaxi Construction Supervision Co., Ltd. (深圳市華西建設監理有限公司) from 1993 to 2001. Mr. Jin received his Bachelor’s degree in conservancy and hydropower engineering from Jiangxi Industrial University (江西工業大學) in 1987.

**Mr. ZHOU Yibo** (周宜波), aged 49, is the general manager of Shenzhen Huiheng Property Company Limited (originally named as Shenzhen Fantasia) (深圳市匯恒置業有限公司) (“Shenzhen Fantasia”). Mr. Zhou joined our Group in December 2010 and is responsible for the operation of Shenzhen Fantasia (深圳花樣年). Prior to joining the Group, he was the general manager of Shenzhen Zhu Jiang Real Estates Development Company Limited (深圳市珠江房地產開發有限公司) from 2006 to 2010, the general manager of the brokerage department of Dapeng Securities Limited (大鵬證券) from 1998 to 2004, and the manager of Vanke Enterprise Company Limited Wuhan Branch (萬科企業股份有限公司武漢分公司) from 1992 to 1998. Mr. Zhou received a bachelor degree in economics in 1986 and a master degree in finance from Wuhan University (武漢大學) in 1989, respectively and received a doctoral degree in management from Xi’an Jiaotong University (西安交通大學) in 2009.

**Mr. ZHANG Zhong** (章忠), aged 44, is the general manager of the Tianjin Fantasia Investment Company Limited (天津市花樣年投資有限公司) (“Tianjin Fantasia Investment”) and Huawanli Investment (Beijing) Company Limited (花萬里投資(北京)有限公司) (“Beijing Huawanli”). Mr. Zhang joined our Group in May 2010 and is responsible for the operations of the Tianjin Fantasia Investment and Beijing Huawanli. He was a general manager of a regional branch of Lenovo Holding Roycom Real Estate Company (聯想控股融科智地房地產公司) from 2006 to 2010, the vice-general manager of Beijing Jiayuan Property Co., Ltd. (北京嘉源置業有限公司) from 2004 to 2006, and the general manager of the Business Development Department of Lenovo Holding Roycom Real Estate Company (聯想控股融科智地房地產公司) from 1994 to 2004. Mr. Zhang received his Bachelor’s degree in civil engineering and Master’s degree in structural engineering from Wuhan University of Hydraulic and Electric Engineering (武漢水利電力大學) in 1990 and 1993 respectively.

**Mr. GUO Xiaobin** (郭曉斌), aged 45, is the general manager of Guilin Fantasia Property Development Company Limited (桂林市花樣年房地產開發有限公司) (“Guilin Fantasia”). Mr. Guo joined our Group in June 2010 and is responsible for the operation of Guilin Fantasia. Prior to joining the Group, Mr. Guo was the vice-general manager of CITIC Investment Co., Ltd. (Fujian) (中信(福建)投資有限公司) from 2007 to 2010, a vice general manager of Shenzhen Huadi Investment Co., Ltd. (深圳華地投資有限公司) from 2003 to 2007 and the general manager of the project department and the deputy general manager of the Property Department of the Nanyou Group (南油集團) from 1999 to 2003. Mr. Guo received his Bachelor’s degree in structural engineering from Tongji University (同濟大學) in 1990.

**Mr. SUN Hong** (孫洪), aged 39, is the general manager of Chengdu Fantasia Real Estate Development Company Limited (成都市花樣年房地產開發有限公司) (“Chengdu Fantasia”). Mr. Sun joined our Group in May 2002 and is primarily responsible for the operation of Chengdu Fantasia. He was the manager of the research and development department, assistant to the general manager, deputy general manager, operation deputy general manager and deputy executive general manager of Chengdu Tonghe from 2002 to 2011. Prior to joining the Group, he was the director of the research and development department and the assistant to deputy general manager of Chengdu Singhu Real Estate integrated Development Co., Ltd. (成都天竺房地產綜合開發公司) from 1996 to 2002. Mr. Sun received a Bachelor’s degree in engineering management in Sichuan University (四川大學) in 2005.

**Mr. LI Xiaojun** (李小軍), aged 37, is the general manager of Nanjing Fantasia Real Estate Development Company Limited (南京花樣年房地產開發有限公司) (“Nanjing Fantasia”). Mr. Li joined our Group in July 2011 and is responsible for the operation of Nanjing Fantasia. Prior to joining the Group, he was the deputy general manager of Evergrande Real Estate Group Nanjing Branch (恒大地產南京區域公司) and the general manager of Sunan Company (蘇南公司) from 2006 to 2011, as well as the deputy general manager of the project company of Hopson Development Holdings Limited Huizhou Company (合生創展集團惠州公司項目公司) in 2006. Mr. Li received a Bachelor’s degree in urban planning (城市規劃) from the Faculty of Civil Engineering (土木工程系) of Guangdong University of Technology (廣東工業大學) in 1991.

**Ms. CHENG Jianli** (程建麗), aged 40, is the general manager of Huizhou Daya Bay Huawanli Industry Company Limited (惠州大亞灣花萬里實業有限公司). Ms. Cheng joined our Group in July 2004 and has served as the human resources director and deputy general manager of the human resources department of Fantasia Property Group Limited (花樣年地產集團有限公司) and the assistant to the general manager of Tianjin Songjiang-Fantasia Real Estate Co., Ltd. (天津松江花樣年置業有限公司). Currently, she is responsible for the operation of Huizhou Fantasia. Prior to joining to the Group, Ms. Cheng was the manager in the General Manager Office of Shenzhen Fu-Yi-Da Investment and Development Co. Ltd. (深圳富怡達投資發展有限公司) from 2001 to 2004. Ms. Cheng received a Bachelor’s degree in Chinese language and literature (漢語言文學) from Shaanxi Normal University (陝西師範大學) in 1994.

**Mr. SHI Bao An** (史寶安), aged 56, is the general manager of Wuxi Fantasia Property Development Company Limited (無錫市花樣年房地產開發有限公司) (“Wuxi Fantasia”) and Suzhou Fantasia Property Development Company Limited (蘇州花樣年房地產開發有限公司) (“Suzhou Fantasia”). Mr. Shi joined our Group in April 2005 and has served as the manager of project department of Shenzhen Fantasia Property Development Company Limited (深圳市花樣年房地產有限公司) and the manager of project department, director of engineering, Engineering Commercial Director of Chengdu Tonghe Real

Estate Co., Ltd. (成都通和置業有限公司). Currently, he is responsible for overall operations of Wuxi Fantasia and Suzhou Fantasia. Prior to joining the Group, he was the director of Shenzhen Xiandai Supervision Co., Ltd. (深圳現代監理公司) from 1991 to 2005 and the project manager of The Second Construction Co., Ltd of China Construction Third Engineering Bureau (中建三局二公司) from 1987 to 1991. Mr. Shi completed his tertiary education from South China University of Technology (華南理工大學) in 1990.

**Mr. LIN Zhengze** (林政澤), aged 45, is the general manager of Fantasia (Taiwan) Development Co., Ltd. (台灣花樣年開發股份有限公司) (“Taiwan Fantasia”). Mr. Lin joined our Group in August 2011 and is responsible for the operation of Taiwan Fantasia. Prior to joining to the Group, he has served as the assistant manager of corporate finance department of Taiwan Pang’s/Pen Bay International Development (Holdings) Company (台灣潘氏/大鵬灣國際開發(股)公司) and Ma-Tai-An International Development (Holdings) Company (馬太鞍國際開發(股)公司) and the general manager of Tai-Da Back Garden (Holdings) Company (台大後花園(股)公司) from 2006 to 2011, the chief financial officer of digital technology department of baiy.net (百娛網) and the deputy general manager of Hua Yu Commercial Realty (華宇商用不動產) from 2006 to 2011. Mr. Lin received a Bachelor’s degree in business from the Faculty of Accounting of the Soochow University Business School (東吳大學商學院) in 1990.

**Mr. LAW Sai Kuen** (羅世權), aged 49, is the general manager in our hotel construction center of Shenzhen Fantasia Real Estate Group Limited. Mr. Law joined our Group in November 2010 and is responsible for the operation of our Group’s hotel construction center. Prior to joining our Group, he was the project manager of Shangrila Hotel Management Co., Ltd. (香格里拉酒店管理有限公司) from 2003 to 2010 and the senior project manager of Decca Holdings Limited (達藝控股有限公司) from 1996 to 2003. Mr. Law received a Master’s degree in project management from Sydney Institute of Technology (悉尼技術學院) in 2004.

**Mr. LIU Jun** (劉軍), aged 44, is the general manager of Shenzhen Fantasia Hotel Management Company Limited (深圳市花樣年酒店管理有限公司). Mr. Liu joined our Group in December 1999 and is primarily responsible for hotel management operations. He has been the deputy general manager of Fantasia Group Xingyan Property Consultancy Co., Ltd. (花樣年集團星彥地產顧問有限公司), Shenzhen Xingyanhang Property Co., Ltd. (深圳市星彥行置業有限公司) and Shenzhen Fantasia Colour Life Technology Co., Ltd. (深圳市花樣年彩生活科技有限公司). Prior to joining the Group, he was the person-in-charge of the construction of Baise Hotel of Bank of China Group (中銀集團百色大酒店) from 1998 to 1999, the manager of the personnel and training department of Beihai Furama Hotel (北海富麗華大酒店) from 1994 to 1997. Mr. Liu received a Master’s degree in International Business Administration (國際工商管理) from Guanghua School of Management of Peking University (北京大學光華管理學院) in 2005.

**Mr. CHEN Xiang Ming** (陳湘明), aged 42, is the general manager of Fantasia Property Management (International) Co., Ltd. (花樣年物業管理(國際)有限公司) (“Fantasia Property Management International”). Mr. Chen was the vice-general manager of Shenzhen Fantasia Property Management Co., Ltd. (深圳市花樣年物業管理有限公司) from 2002 to 2006, a general manager of Shenzhen Excellence Property Management Co., Ltd. (深圳市卓越物業管理有限公司) from 2006 to 2007, Shenzhen Terra Property Management Co., Ltd. (深圳市泰然物業管理有限公司) from 2007 to 2011 and Shenzhen Baopu Property Management Co., Ltd. (深圳市抱樸物業管理有限公司) from 2011 to 2012. Since 2012, Mr. Chen rejoined our Group in his current position. Mr. Chen completed his tertiary education in Safety Engineering from Hunan University Hengyang Campus in 1992.

## **Company Secretary**

**Mr. LAM Kam Tong** (林錦堂), aged 44. For details regarding Mr. Lam’s experience, see the paragraph entitled “Directors” above in this section.

## **Board Committees**

### ***Audit Committee***

Our Company established an audit committee on October 12, 2009 with written terms of reference as amended, in compliance with the Listing Rules. The audit committee is responsible for the engagement

of the external auditor, review of the Group's financial information and oversight of the Group's financial reporting system and internal control and risk management procedures and reviewing the Group's financial and accounting policies and practices.

The audit committee comprises four members, namely, Mr. HO Man (何敏), Mr. LIAO Martin Cheung Kong, JP (廖長江), Mr. HUANG Ming (黃明) and Mr. XU Quan (許權). They are all independent non-executive directors. The audit committee is chaired by Mr. HO Man (何敏).

#### ***Remuneration Committee***

Our Company established a remuneration committee on October 12, 2009 with written terms of reference as amended, in compliance with the Listing Rules. The remuneration committee is responsible for making recommendations to the board on the Company's remuneration policy and structure for all directors and senior management and on the establishment of a formal and transparent procedure for developing such policy.

The remuneration committee comprises five members, namely, Mr. HUANG Ming (黃明), Mr. HO Man (何敏), Mr. LIAO Martin Cheung Kong, JP (廖長江), Mr. XU Quan (許權) and Mr. PAN Jun (潘軍). The remuneration committee is chaired by Mr. HUANG Ming (黃明).

#### ***Nomination Committee***

Our Company established a nomination committee on October 12, 2009 with written terms of reference as amended in compliance with the Listing Rules. The nomination committee is responsible for reviewing the structure, size and composition of the board, assessing the independence of the independent non-executive directors and making recommendations to the board on the appointment and re-appointment of directors.

The nomination committee comprises six members, namely, Mr. PAN Jun (潘軍), Mr. HO Man (何敏), Mr. LIAO Martin Cheung Kong, JP (廖長江), Mr. HUANG Ming (黃明), Mr. XU Quan (許權) and Ms. ZENG Jie, Baby (曾寶寶). The nomination committee is chaired by Mr. PAN Jun (潘軍).

### **Compensation of Directors and Senior Management**

The Group's remuneration policies are formulated based on qualifications, years of experiences and the performance of individual employees and are reviewed regularly.

The aggregate amount of compensation (including any salaries, fees, discretionary bonuses and other allowances and benefits in kind) paid by us during each of the three years ended December 31, 2010, 2011 and 2012, to those persons who have been or are our directors, was approximately RMB10.1 million, RMB8.6 million and RMB9.8 million (US\$1.6 million), respectively.

### **Share Option Scheme**

We adopted our share option scheme on October 27, 2009 in order to reward eligible participants who contribute to the Group and to encourage eligible participants to work towards enhancing the value of the Company. Eligible participants include our directors and employees and any advisors, consultants, distributors, contractors, suppliers, agents, customers, business partners, joint venture business partners, promoters or service providers of any member of our Group who our board of directors considers, in its sole discretion, have contributed or will contribute to the Group. We have granted options to certain of our directors and employees and, as of December 31, 2012, options to subscribe for up to 119,400,000 shares of our Company are outstanding.

## Directors' and Chief Executives' Interests

As of December 31, 2012, the interests and short positions of our directors and chief executives in the shares and underlying shares of the Company, which will have to be notified to the Company and the Stock Exchange pursuant to Divisions 7 and 8 of Part XV of the Securities and Futures Ordinance of Hong Kong (the "SFO") (including interests and short positions which he/she is taken or deemed to have under such provisions of the SFO) or which will be required, as recorded in the register maintained by the Company pursuant to Section 352 of the SFO, or as otherwise notified to the Company and the Hong Kong Stock Exchange pursuant to the Model Code for Securities Transactions by Directors of Listed Companies were as follows:

Director	Nature of Interests	Number of Shares Held	Interest in Underlying Shares	Approximate Percentage of Shareholding
Zeng Jie, Baby . . . . .	Interest of controlled corporation <sup>(1)</sup>	3,184,795,500	–	61.16%
	Personal	–	9,980,000 <sup>(2)</sup>	0.19%
Pan Jun . . . . .	Personal	–	9,980,000 <sup>(2)</sup>	0.19%
Lam Kam Tong . . . . .	Personal	–	2,770,000 <sup>(2)</sup>	0.05%
Ho Man . . . . .	Personal	–	1,600,000 <sup>(2)</sup>	0.03%
Liao Martin Cheung Kong, JP .	Personal	–	1,600,000 <sup>(2)</sup>	0.03%
Huang Ming . . . . .	Personal	–	1,600,000 <sup>(2)</sup>	0.03%
Xu Quan . . . . .	Personal	–	1,600,000 <sup>(2)</sup>	0.03%

*Notes:*

- (1) *Fantasy Pearl International Limited ("Fantasy Pearl") is owned as to 80% by Ice Apex Limited ("Ice Apex") and 20% by Graceful Star Overseas Limited ("Graceful Star"). While Ice Apex is wholly owned by Ms. Zeng Jie, Baby, Ms. Zeng Jie, Baby is deemed to be interested in the shares of the Company held by Fantasy Pearl for the purpose of Part XV of the SFO.*
- (2) *The relevant director was granted options to subscribe for such number of shares under the Share Option Scheme on August 29, 2011 and October 16, 2012.*



## PRINCIPAL SHAREHOLDERS

As of December 31, 2012, so far as the directors are aware, the following persons or institutions have beneficial interests or short positions in any shares or underlying shares of the Company which would fall to be disclosed to the Company under the provisions of Divisions 2 and 3 of Part XV of the SFO, Cap 571 of the Laws of Hong Kong, or who is directly and/or indirectly interested in 10% or more of the nominal value of any class of share capital carrying rights to vote in all circumstances at general meetings of any other member of the Group:

Name of shareholder	Nature of Interest	Number of shares	Approximate percentage of interest in our Company as of December 31, 2012
Fantasy Pearl International Limited. . .	Beneficial interest <sup>(1)</sup>	3,184,795,500	61.16%
Ice Apex Limited . . . . .	Interest of controlled corporation <sup>(2)</sup>	3,184,795,500	61.16%
Ms. Zeng Jie, Baby . . . . .	Interest of controlled corporation	3,184,795,500	61.16%

*Notes:*

- (1) *Fantasy Pearl is owned as to 80% by Ice Apex and 20% by Graceful Star. Ice Apex is deemed to be interested in the shares held by Fantasy Pearl for the purpose of Part XV of the SFO. Graceful Star is entitled to a pre-emptive right over shares in the capital of Fantasy Pearl pursuant to an agreement made between, among others, Ms. Zeng Jie, Baby, Mr. Pan Jun, Ice Apex and Graceful Star.*
- (2) *Ice Apex is wholly owned by Ms. Zeng Jie, Baby. Ms. Zeng Jie, Baby is deemed to be interested in the shares held by Ice Apex for the purpose of Part XV of the SFO.*

Except as disclosed above, as of December 31, 2012, no other shareholder, other than directors or chief executives, of the Company had any interests or short positions in the shares or underlying shares of the Company as recorded in the register required to be kept under section 336 of the SFO.

## RELATED PARTY TRANSACTIONS

The following discussion describes certain material related party transactions between us or our consolidated subsidiaries and our directors, executive officers and principal shareholders and, in each case, the companies with whom they are affiliated. Each of our related party transactions was entered into in the ordinary course of business, on fair and reasonable commercial terms, in our interests and the interests of our shareholders.

The table below sets forth certain material transactions between us and our related parties during the three years ended December 31, 2010, 2011 and 2012:

Related parties	Relationship	Transactions	For the year ended December 31,		
			2010	2011	2012
(RMB in thousands)					
Huidong Dayawan San Jiao Zhou Company Limited 惠東縣大亞灣三角洲俱樂部有限公司 . . . . .	A related company controlled by Ms. Zeng Jie, Baby, a controlling shareholder and director of the Company	Management service fee received	500	980	612
Shenzhen Xi Fu Hui Club Management Company Limited 深圳喜福會會所管理有限公司 . . . . .	A related company controlled by Ms. Zeng Jie, Baby, a controlling shareholder and director of the Company	Property rental income received	301	301	301
Shenzhen Cube Architecture Designing Consultants Company Limited 深圳立方建築設計顧問有限公司	An associate of Shenzhen Tiankuo Investment Co., Ltd., a related company controlled by Ms. Zeng Jie, Baby, the controlling shareholder and director of the Company	Design services fee paid	–	4,154	1,099
Mr. Yu Shui 于水先生 . . . . .	Non-controlling shareholder of a subsidiary of the Company	Consideration paid in respect of acquisition of additional interest in a subsidiary of the Group	–	332,440	–
Zhongxu Investment Limited 中旭投資有限公司 . . . . .	Non-controlling shareholder of a subsidiary of the Company	Consideration paid in respect of acquisition of additional interest in a subsidiary of the Group	–	10,000	–

During the three years ended December 31, 2010, 2011 and 2012, the Group sold certain properties to its key management personnel at a cash consideration of approximately RMB10.7 million, RMB6.5 million and RMB26.2 million (US\$4.2 million), respectively.

## DESCRIPTION OF MATERIAL INDEBTEDNESS AND OTHER OBLIGATIONS

To fund our existing property projects and to finance our working capital requirements, we have entered into financing agreements with various financial institutions and enterprises. As of December 31, 2012, our total borrowings (excluding the 2010 Notes, the 2012 Notes and amounts due to related parties) amounted to RMB5,552.4 million (US\$891.2 million). Set forth below is a summary of the material terms and conditions of these loans and other indebtedness.

### **PRC Loan Agreements**

Certain of our PRC subsidiaries have entered into loan agreements with local branches of various PRC banks and financial institutions, including Industrial and Commercial Bank of China, The Agricultural Bank of China, Huaxia Bank, China Everbright Bank, Dongguan Trust Co., Ltd., Shanghai Pudong Development Bank, Bank of Beijing, Bank of China, ICBC (Asia), AVIC Trust, Bank of Communications, Rural Commercial Bank and Bank of Chengdu. These loans include project loans to finance the construction of our projects and loans to finance our working capital requirements. They have terms ranging from 12 months to 96 months, which generally correspond to the construction periods of the particular projects. As of December 31, 2012, the aggregate outstanding amount under these loans totaled approximately RMB4,498.0 million (US\$722.0 million), of which RMB1,927.5 million (US\$309.4 million) was due within one year and RMB2,570.5 million (US\$412.6 million) was due between one and five years. Our PRC loans are typically secured by land use rights and properties as well as guaranteed by certain of our other PRC subsidiaries.

#### *Interest*

The principal amounts outstanding under the PRC loans generally bear interest at floating rates calculated with reference to the PBOC benchmark interest rate. Floating interest rates are generally subject to annual or quarterly review by the lending banks. Interest payments are payable either monthly or quarterly and must be made on each payment date as provided in the particular loan agreement. As of December 31, 2012, the weighted average interest rate on the aggregate outstanding amount of our PRC loans was 7.55% per annum.

#### *Covenants*

Under these PRC loans, many of our subsidiary borrowers have agreed, among other things, not to take the following actions without obtaining the relevant lender's prior consent:

- creating encumbrances on any part of their property or assets or dealing with their assets in a way that may adversely affect their ability to repay their loans;
- granting guarantees to any third parties that may adversely affect their ability to repay their loans;
- making any major changes to their corporate structures, such as entering into joint ventures, mergers, acquisitions and reorganizations;
- altering the nature or scope of their business operations in any material respect;
- transferring part or all of their liabilities under the loans to a third party;
- prepaying the loans;
- selling or disposing of assets; and
- incurring other indebtedness that may adversely affect their ability to repay their loans.

### ***Events of Default***

The PRC loan agreements contain certain customary events of default, including failure to pay the amount payable on the due date, unauthorized use of loan proceeds, failure to obtain the lender's approval for an act that requires the latter's approval, and material breach of the terms of the loan agreement. The banks are entitled to terminate their respective agreements and/or demand immediate repayment of the loans and any accrued interest upon the occurrence of an event of default.

### ***Guarantee and Security***

Certain of our PRC subsidiaries have entered into guarantee agreements with the PRC banks and financial institutions in connection with some of the PRC loans pursuant to which these subsidiaries have guaranteed all liabilities of the subsidiary borrowers under these loans. Further, as of December 31, 2012, RMB3,728.0 million (US\$598.4 million) of the PRC loans were secured by land use rights and properties held by the subsidiary borrowers and/or our other PRC subsidiaries.

### **2010 Notes**

On May 12, 2010, we entered into an indenture (as amended and supplemented from time to time, the "2010 Indenture") pursuant to which we issued US\$120,000,000 principal amount of the 14% Senior Notes due 2015. As of December 31, 2012, the entire principal amount of the 2010 Notes remained outstanding.

#### ***Guarantee***

Our obligations under the 2010 Notes are guaranteed by our existing subsidiaries (the "2010 Subsidiary Guarantors") other than those organized under the laws of the PRC and certain other subsidiaries specified in the 2010 Indenture. Under certain circumstances and subject to certain conditions, a guarantee by a 2010 Subsidiary Guarantor may be replaced by a limited-recourse guarantee, referred to as a JV Subsidiary Guarantee in the 2010 Indenture. Each of the 2010 Subsidiary Guarantors, jointly and severally, guarantees the due and punctual payment of the principal, any premium, and interest on, and all other amounts payable under, the 2010 Notes.

#### ***Collateral***

In order to secure the obligations under the 2010 Notes, the Company and the 2010 Subsidiary Guarantors under the 2010 Indenture pledged the capital stock of all such 2010 Subsidiary Guarantors for the benefit of the holders of the 2010 Notes (the "2010 Notes Collateral"). The 2010 Notes Collateral may be released or reduced in the event of certain asset sales and certain other circumstances. In addition, the Company and each subsidiary guarantor pledgor under the 2010 Indenture may, subject to certain conditions, incur additional indebtedness provided that such indebtedness would be on a *pari passu* basis with the 2010 Notes and the related subsidiary guarantees, and other *pari passu* secured indebtedness permitted under the 2010 Indenture.

#### ***Interest***

The 2010 Notes bear an interest rate of 14% per annum, payable semi-annually in arrears.

#### ***Covenants***

Subject to certain conditions and exceptions, the 2010 Indenture contains certain covenants, restricting us and each of the related restricted subsidiaries from, among other things:

- incurring or guaranteeing additional indebtedness and issuing disqualified or preferred stock;
- declaring dividends on its capital stock or purchasing or redeeming capital stock;
- making investments or other specified restricted payments;

- issuing or selling capital stock of the certain restricted subsidiaries;
- guaranteeing indebtedness of the related restricted subsidiaries;
- selling assets;
- creating liens;
- entering into sale and leaseback transactions;
- engaging in any business other than permitted business;
- entering into agreements that restrict the related restricted subsidiaries' ability to pay dividends, transfer assets or make intercompany loans;
- entering into transactions with shareholders or affiliates; and
- effecting a consolidation or merger.

### ***Events of Default***

The 2010 Indenture contains certain customary events of default, including default in the payment of principal, or of any premium, on the 2010 Notes, when such payments become due, default in payment of interest which continues for 30 days, breaches of covenants, insolvency and other events of default specified in the 2010 Indenture. If an event of default occurs and is continuing, the trustee under the 2010 Indenture or the holders of at least 25% of the outstanding 2010 Notes may declare the principal of the 2010 Notes plus any accrued and unpaid interest and premium (if any) to be immediately due and payable.

### ***Change of Control***

Upon the occurrence of a certain event of change of control and a rating decline, we are obligated to make an offer to repurchase all outstanding 2010 Notes at a purchase price equal to 101% of their principal amount plus any accrued and unpaid interest.

### ***Maturity and Redemption***

The maturity date of the 2010 Notes is May 12, 2015.

At any time, we may redeem the 2010 Notes, in whole but not in part, at a redemption price equal to 100% of the principal amount of the 2010 Notes, plus a premium and any accrued and unpaid interest to (but not including) the redemption date.

At any time prior to May 12, 2013, we may redeem up to 35% of the aggregate principal amount of the 2010 Notes at a redemption price equal to 114% of the principal amount of the 2010 Notes, plus any accrued and unpaid interest with the proceeds from sales of certain kinds of the Company's capital stock, subject to certain conditions.

Additionally, if we or a subsidiary guarantor under the 2010 Indenture would become obligated to pay certain additional amounts as a result of certain changes in specified tax law, we may redeem the 2010 Notes at a redemption price equal to 100% of the principal amount of the 2010 Notes, plus any accrued and unpaid interest, subject to certain exceptions.

### ***Consent Solicitation***

In March 2013, we conducted a solicitation of consents from holders of our 2010 Notes to amend certain terms of the 2010 Notes to conform to the 2012 Notes.

## 2012 Notes

On September 27, 2012, we entered into an indenture (as amended and supplemented from time to time, the “2012 Indenture”) pursuant to which we issued US\$250,000,000 principal amount of the 13.75% Senior Notes due 2017. As of date of this offering memorandum, the entire principal amount of the 2012 Notes remained outstanding.

### *Guarantee*

Our obligations under the 2012 Notes are guaranteed by our existing subsidiaries (the “2012 Subsidiary Guarantors”) other than those organized under the laws of the PRC and certain other subsidiaries specified in the 2012 Indenture. Under certain circumstances and subject to certain conditions, a guarantee by a 2012 Subsidiary Guarantor may be replaced by a limited-recourse guarantee, referred to as a JV Subsidiary Guarantee in the 2012 Indenture. Each of the 2012 Subsidiary Guarantors, jointly and severally, guarantees the due and punctual payment of the principal, any premium, and interest on, and all other amounts payable under, the 2012 Notes.

### *Collateral*

In order to secure the obligations under the 2012 Notes, the Company and the 2012 Subsidiary Guarantors under the 2012 Indenture pledged the capital stock of all such 2012 Subsidiary Guarantors for the benefit of the holders of the 2012 Notes (the “2012 Notes Collateral”). The 2012 Notes Collateral may be released or reduced in the event of certain asset sales and certain other circumstances. In addition, the Company and each subsidiary guarantor pledgor under the 2012 Indenture may, subject to certain conditions, incur additional indebtedness provided that such indebtedness would be on a *pari passu* basis with the 2012 Notes and the related subsidiary guarantees, and other *pari passu* secured indebtedness permitted under the 2012 Indenture.

### *Interest*

The 2012 Notes bear an interest rate of 13.75% per annum, payable semi-annually in arrears.

### *Covenants*

Subject to certain conditions and exceptions, the 2012 Indenture contains certain covenants, restricting us and each of the related restricted subsidiaries from, among other things:

- incurring or guaranteeing additional indebtedness and issuing disqualified or preferred stock;
- declaring dividends on its capital stock or purchasing or redeeming capital stock;
- making investments or other specified restricted payments;
- issuing or selling capital stock of the related restricted subsidiaries;
- guaranteeing indebtedness of the related restricted subsidiaries;
- selling assets;
- creating liens;
- entering into sale and leaseback transactions;
- engaging in any business other than permitted business;

- entering into agreements that restrict the related restricted subsidiaries' ability to pay dividends, transfer assets or make intercompany loans;
- entering into transactions with shareholders or affiliates; and
- effecting a consolidation or merger.

### ***Events of Default***

The 2012 Indenture contains certain customary events of default, including default in the payment of principal, or of any premium, on the 2012 Notes, when such payments become due, default in payment of interest which continues for 30 days, breaches of covenants, insolvency and other events of default specified in the 2012 Indenture. If an event of default occurs and is continuing, the trustee under the 2012 Indenture or the holders of at least 25% of the outstanding 2012 Notes may declare the principal of the 2012 Notes plus any accrued and unpaid interest and premium (if any) to be immediately due and payable.

### ***Change of Control***

Upon the occurrence of a certain event of change of control and a rating decline, we are obligated to make an offer to repurchase all outstanding 2012 Notes at a purchase price equal to 101% of their principal amount plus any accrued and unpaid interest.

### ***Maturity and Redemption***

The maturity date of the 2012 Notes is September 27, 2017.

At any time, we may redeem the 2012 Notes, in whole but not in part, at a redemption price equal to 100% of the principal amount of the 2012 Notes, plus a premium and any accrued and unpaid interest to (but not including) the redemption date.

At any time prior to September 27, 2015, we may redeem up to 35% of the aggregate principal amount of the 2012 Notes at a redemption price equal to 113.75% of the principal amount of the 2012 Notes, plus any accrued and unpaid interest with the proceeds from sales of certain kinds of the Company's capital stock, subject to certain conditions.

Additionally, if we or a subsidiary guarantor under the 2012 Indenture would become obligated to pay certain additional amounts as a result of certain changes in specified tax law, we may redeem the 2012 Notes at a redemption price equal to 100% of the principal amount of the 2012 Notes, plus any accrued and unpaid interest, subject to certain exceptions.

### ***Intercreditor Agreement***

On September 27, 2012, the Company, the subsidiary guarantor pledgors under the Indenture, the common security agent, the trustee for the 2010 Notes for the benefit of holders of the 2010 Notes and the trustee for the 2012 Notes for the benefit of holders of the 2012 Notes entered into an intercreditor agreement (as amended from time to time, the "Intercreditor Agreement"). The Intercreditor Agreement provides that the security interests created by the 2012 Notes Collateral will be shared on a *pari passu* basis among (i) the holders of the 2010 Notes, (ii) the holders of the 2012 Notes and (iii) any holder of permitted *pari passu* secured indebtedness or their representatives who become parties to the intercreditor agreement.

## **Hong Kong Loan Agreements**

Certain of our Hong Kong subsidiaries, including Hong Kong Huawanli Trading Co., Limited, a 2010 Subsidiary Guarantor and 2012 Subsidiary Guarantor that will also guarantee the Notes offered hereby, Hong Kong Kangnian Trading Co., Limited, a subsidiary that is not a 2010 Subsidiary Guarantor and not a 2012 Subsidiary Guarantor and will not guarantee the Notes offered hereby, and Fantasia Investment Holdings Company Limited, a 2010 Subsidiary Guarantor and 2012 Subsidiary Guarantor that will also guarantee the Notes offered hereby, have entered into loan agreements with offshore banks, including Industrial and Commercial Bank of China, Paris Branch, Industrial and Commercial Bank of China (Asia) Limited and The Hongkong and Shanghai Banking Corporation Limited to finance acquisitions, investments and for general corporate purposes. Such loan agreements have terms ranging from 12 months to 54 months. As of December 31, 2012, the aggregate outstanding amount under these loans totaled approximately RMB483.0 million (US\$77.5 million), RMB571.4 million (US\$91.7 million) of which was due within one year.

### ***Guarantee and Security***

Two of the loan agreements entered into by Hong Kong Kangnian Trading Co., Limited are guaranteed by its PRC parent holding company. One loan agreement entered into by Fantasia Investment Holdings Company Limited as borrower and The Hongkong and Shanghai Banking Corporation Limited as lender (the “HSBC Loan Agreement”) is secured by a limited guarantee of up to HK\$250 million by the Company and a cash deposit equivalent to 20% of the outstanding loan balance. The other loans are not guaranteed. Some of these loans are secured by a standby letter of credit issued by PRC banks which letter of credit is supported by a guarantee and/or collateral pledged by certain PRC subsidiaries.

### ***Interest***

The principal amounts outstanding under these loans generally bear interest at floating rates calculated with reference to the London Interbank Offered Rate or Hong Kong Interbank Offered Rate.

### ***Covenants***

Under the loan agreement dated March 9, 2011, between Hong Kong Kangnian Trading Co., Ltd. as borrower and Industrial and Commercial Bank of China (Asia) Limited as lender, for a loan of up to US\$70 million, Hong Kong Kangnian Trading Co., Limited has agreed, among others, that it will not create or permit or arise or subsist any encumbrance over its present or future assets or any part thereof for any future indebtedness, loan, guarantee or other financial obligation, contingent or otherwise. Under the HSBC Loan Agreement dated April 21, 2010, for a loan of up to HK\$165 million and a revolving credit facility of up to HK\$85 million, Fantasia Investment Holdings Company Limited has agreed, among others, to maintain a consolidated net external gearing (ratio of total interest bearing debt to consolidated tangible net worth plus non-redeemable preference shares and minority interest) of not more than 0.9 and a consolidated tangible net worth of not less than RMB3,000 million at all times.

### ***Events of Default***

These Hong Kong loans contain certain customary events of default, including non-payment of principal or interest, cross default, insolvency and breaches of its terms. If an event of default occurs, all amounts outstanding including all interest accrued thereon may become immediately due and payable.



## January 2013 Notes

On January 22, 2013, we entered into an indenture (as amended and supplemented from time to time, the “January 2013 Indenture”) pursuant to which we issued US\$250,000,000 principal amount of the 10.75% Senior Notes due 2020. As of date of this offering memorandum, the entire principal amount of the January 2013 Notes remained outstanding.

### *Guarantee*

Our obligations under the January 2013 Notes are guaranteed by our existing subsidiaries (the “January 2013 Subsidiary Guarantors”) other than those organized under the laws of the PRC and certain other subsidiaries specified in the January 2013 Indenture. Under certain circumstances and subject to certain conditions, a guarantee by a January 2013 Subsidiary Guarantor may be replaced by a limited-recourse guarantee, referred to as a JV Subsidiary Guarantee in the January 2013 Indenture. Each of the January 2013 Subsidiary Guarantors, jointly and severally, guarantees the due and punctual payment of the principal, any premium, and interest on, and all other amounts payable under, the January 2013 Notes.

### *Collateral*

In order to secure the obligations under the January 2013 Notes, the Company and the January 2013 Subsidiary Guarantors under the January 2013 Indenture pledged the capital stock of all such January 2013 Subsidiary Guarantors for the benefit of the holders of the January 2013 Notes (the “January 2013 Notes Collateral”). The January 2013 Notes Collateral may be released or reduced in the event of certain asset sales and certain other circumstances. In addition, the Company and each subsidiary guarantor pledgor under the January 2013 Indenture may, subject to certain conditions, incur additional indebtedness provided that such indebtedness would be on a *pari passu* basis with the January 2013 Notes and the related subsidiary guarantees, and other *pari passu* secured indebtedness permitted under the January 2013 Indenture. The trustee for the January 2013 Notes acceded to the Intercreditor Agreement, which had provided that the collateral under the January 2013 Notes is to be shared on a *pari passu* basis among the holders of the 2010 Notes, the holders of the 2012 Notes, the holders of the January 2013 Notes and the holders of other permitted *pari passu* indebtedness.

### *Interest*

The January 2013 Notes bear an interest rate of 10.75% per annum, payable semi-annually in arrears.

### *Covenants*

Subject to certain conditions and exceptions, the January 2013 Indenture contains certain covenants, restricting us and each of the related restricted subsidiaries from, among other things:

- incurring or guaranteeing additional indebtedness and issuing disqualified or preferred stock;
- declaring dividends on its capital stock or purchasing or redeeming capital stock;
- making investments or other specified restricted payments;
- issuing or selling capital stock of the related restricted subsidiaries;
- guaranteeing indebtedness of the related restricted subsidiaries;
- selling assets;
- creating liens;
- entering into sale and leaseback transactions;

- engaging in any business other than permitted business;
- entering into agreements that restrict the related restricted subsidiaries' ability to pay dividends, transfer assets or make intercompany loans;
- entering into transactions with shareholders or affiliates; and
- effecting a consolidation or merger.

### ***Events of Default***

The January 2013 Indenture contains certain customary events of default, including default in the payment of principal, or of any premium, on the January 2013 Notes, when such payments become due, default in payment of interest which continues for 30 days, breaches of covenants, insolvency and other events of default specified in the January 2013 Indenture. If an event of default occurs and is continuing, the trustee under the January 2013 Indenture or the holders of at least 25% of the outstanding January 2013 Notes may declare the principal of the January 2013 Notes plus any accrued and unpaid interest and premium (if any) to be immediately due and payable.

### ***Change of Control***

Upon the occurrence of a certain event of change of control and a rating decline, we are obligated to make an offer to repurchase all outstanding January 2013 Notes at a purchase price equal to 101% of their principal amount plus any accrued and unpaid interest.

### ***Maturity and Redemption***

The maturity date of the January 2013 Notes is January 22, 2020.

At any time, we may redeem the January 2013 Notes, in whole but not in part, at a redemption price equal to 100% of the principal amount of the January 2013 Notes, plus a premium and any accrued and unpaid interest to (but not including) the redemption date.

At any time prior to January 22, 2016, we may redeem up to 35% of the aggregate principal amount of the January 2013 Notes at a redemption price equal to 110.75% of the principal amount of the January 2013 Notes, plus any accrued and unpaid interest with the proceeds from sales of certain kinds of the Company's capital stock, subject to certain conditions.

Additionally, if we or a subsidiary guarantor under the January 2013 Indenture would become obligated to pay certain additional amounts as a result of certain changes in specified tax law, we may redeem the January 2013 Notes at a redemption price equal to 100% of the principal amount of the January 2013 Notes, plus any accrued and unpaid interest, subject to certain exceptions.

### **Customer Guarantees**

In line with industry practice, we provide guarantees to mortgagee banks in respect of mortgage loans taken out by purchasers of our properties. Such guarantee obligations typically terminate upon the delivery of the relevant property ownership certificates on the underlying property to the bank. As of December 31, 2012, the aggregate outstanding amount guaranteed was RMB2,750.8 million (US\$441.5 million).

## DESCRIPTION OF THE NOTES

For purposes of this “Description of the Notes,” the term “Company” refers only to Fantasia Holdings Group Co., Limited, and any successor obligor on the Notes, and not to any of its subsidiaries. Each Subsidiary of the Company which guarantees the Notes is referred to as a “Subsidiary Guarantor,” and each such guarantee is referred to as a “Subsidiary Guarantee.” Each Subsidiary of the Company that in the future provides a JV Subsidiary Guarantee (as defined below) is referred to as the “JV Subsidiary Guarantor.”

The Notes are to be issued under an indenture (the “Indenture”), to be dated as of May 27, 2013, among the Company, the Subsidiary Guarantors, as guarantors, and Citicorp International Limited, as trustee (the “Trustee”).

The following is a summary of certain provisions of the Indenture, the Notes, the Intercreditor Agreement (as defined below), the Subsidiary Guarantees and the JV Subsidiary Guarantees. This summary does not purport to be complete and is qualified in its entirety by reference to all of the provisions of the Indenture, the Notes, the Intercreditor Agreement, the Subsidiary Guarantees and the JV Subsidiary Guarantees. It does not restate those agreements in their entirety. Whenever particular sections or defined terms of the Indenture not otherwise defined herein are referred to, such sections or defined terms are incorporated herein by reference.

Copies of the Indenture will be available on or after the Original Issue Date at the corporate trust office of the Trustee at 56/F, One Island East, 18 Westlands Road, Island East, Hong Kong.

### Brief Description of the Notes

The Notes are:

- general obligations of the Company;
- senior in right of payment to any existing and future obligations of the Company expressly subordinated in right of payment to the Notes;
- at least *pari passu* in right of payment with all other unsecured, unsubordinated Indebtedness of the Company (subject to any priority rights of such unsubordinated Indebtedness pursuant to applicable law);
- guaranteed by the Subsidiary Guarantors on a senior basis, subject to the limitations described below under the caption “— The Subsidiary Guarantees” and in “Risk Factors — Risks Relating to the Subsidiary Guarantees, the JV Subsidiary Guarantees and the Collateral”;
- effectively subordinated to the other secured obligations (if any) of the Company, the Subsidiary Guarantors and the JV Subsidiary Guarantors, to the extent of the value of the assets serving as security therefor (other than the Collateral); and
- effectively subordinated to all existing and future obligations of the Non-Guarantor Subsidiaries (as defined below).

In addition, on the Original Issue Date, subject to the limitations described in “Risk Factors — Risks Relating to the Subsidiary Guarantees, the JV Subsidiary Guarantees and the Collateral,” the Notes will be secured by a pledge of the Collateral as described below under the caption “— Security” and will:

- be entitled to the benefit of a lien on the Collateral (subject to any Permitted Liens) shared on a *pari passu* basis pursuant to the Intercreditor Agreement (as defined below) with (i) holders of the 2010 Notes; (ii) holders of the 2012 Notes; (iii) holders of the January 2013 Notes; and (iv) holders of other Permitted *Pari Passu* Secured Indebtedness; and

- rank effectively senior in right of payment to unsecured obligations of the Company with respect to the value of the Collateral pledged by the Company securing the Notes (subject to any priority rights of such unsecured obligations pursuant to applicable law).

The Notes will mature on the Interest Payment Date (defined below) on or nearest to May 27, 2016, unless earlier redeemed pursuant to the terms thereof and the Indenture.

The Notes will bear interest at 7.875% per annum from the Original Issue Date or from the most recent interest payment date to which interest has been paid or duly provided for, payable semiannually in arrears on May 27 and November 27 of each year (each an “Interest Payment Date”), commencing November 27, 2013. Interest on the Notes will be paid to Holders of record at the close of business on the fifth Business Day before an Interest Payment Date (each, a “Record Date”), notwithstanding any transfer, exchange or cancellation thereof after a Record Date and prior to the immediately following Interest Payment Date. If any Interest Payment Date would otherwise fall on a day which is not an Interest Payment Business Day, such Interest Payment Date shall be postponed to and become the next day which is an Interest Payment Business Day, unless it would thereby fall into the next calendar month in which event it shall be brought forward to the immediately preceding Interest Payment Business Day. The period beginning on and including May 27, 2013 and ending on but excluding the first Interest Payment Date and each successive period beginning on and including an Interest Payment Date and ending on but excluding the next succeeding Interest Payment Date is called an “Interest Period.” Interest in respect of any Note shall be calculated per CNY100,000 in principal amount of the Notes (the “Calculation Amount”). The amount of interest payable per Calculation Amount for any period shall be calculated by multiplying (1) the product of the rate of interest per annum in respect of the Notes multiplied by the Calculation Amount by (2) the quotient of the actual number of days in the relevant Interest Period divided by 365, and rounding the resulting figure to the nearest CNY0.01 (CNY0.005 being rounded upwards).

Except as described under “Optional Redemption” and otherwise provided in the Indenture, the Notes may not be redeemed prior to maturity (unless they have been repurchased by the Company).

The Indenture allows additional Notes to be issued from time to time (the “Additional Notes”), subject to certain limitations described under “— Further Issues.” Unless the context requires otherwise, references to the “Notes” for all purposes of the Indenture and this “Description of the Notes” include any Additional Notes that are actually issued.

The Notes will be issued only in fully registered form, without coupons, in denominations of CNY1,000,000 and integral multiples of CNY100,000 in excess thereof. No service charge will be made for any registration of transfer or exchange of Notes, but the Company may require payment of a sum sufficient to cover any transfer tax or other similar governmental charge payable in connection therewith.

Payment of principal, premium (if any) and interest due on the Notes other than on an Interest Payment Date will be made by transfer to the Renminbi account maintained by or on behalf of the Holders in Hong Kong (the “Registered Account”), details of which appear on the Note register on the fifth Business Day before the due date for payment. Payment of principal will only be made after surrender of the relevant Notes at the specified office of the Paying and Transfer Agent. Payments of interest on the Notes will be made by transfer to the Registered Account of Holders shown on the Note register at the close of business on the Record Date. Payment instructions for immediately available funds will be initiated on the due date for payment (or, if the due date for payment is not a Business Day, the immediately following Business Day) or, in the case of a payment of principal, if later, on the Business Day on which the relevant Notes are surrendered at the specified office of any Paying Agent or the Note Registrar. Payments on the Notes held in global form by or on behalf of the Operator (defined below) will be made to the persons for whose account a relevant interest in the Notes in global form is credited as being held by the Operator at the relevant time, as notified to the Paying Agent by the Operator in a relevant CMU (defined below) instrument position report or in any other relevant notification by the Operator. See “— Book-Entry; Delivery and Form.” Such payment will discharge our obligations in respect of that payment. Any payments by the CMU participants to indirect participants will be governed by arrangements agreed between the CMU participants and the indirect participants and will continue to

depend on the inter-bank clearing system and traditional payment methods. Such payments will be the sole responsibility of such CMU participants. Interest payable on the Notes held through CMU will be available to CMU participants (as defined herein) no later than the Business Day following payment thereof.

### **The Subsidiary Guarantees**

The initial Subsidiary Guarantors that will execute the Indenture on the Original Issue Date will consist of all of the Company's Restricted Subsidiaries other than (i) those Restricted Subsidiaries organized under the laws of the PRC (the "PRC Non-Guarantor Subsidiaries") and (ii) Talent Bright International Limited, Fantasia Property Management (International) Company Limited, Winning Sky International Limited and Hong Kong Kangnian Trading Co., Limited. (the "Initial Other Non-Guarantor Subsidiaries").

The Subsidiary Guarantors are holding companies that do not have significant operations. None of the existing or future Restricted Subsidiaries organized under the laws of the PRC will provide a Subsidiary Guarantee or JV Subsidiary Guarantee at any time in the future.

The Company will use its commercially reasonable best efforts to take all necessary actions, including obtaining necessary consents or governmental approvals, to cause each of the Other Non-Guarantor Subsidiaries (as defined below) to become a Subsidiary Guarantor or JV Subsidiary Guarantor promptly after such Other Non-Guarantor Subsidiary commences investment for the purposes of commencing business activities, or if any such Other Non-Guarantor Subsidiary has commenced business activities as of the Original Issue Date, as soon as practicable after the Original Issue Date.

In the case of a Restricted Subsidiary (i) that is, or is proposed by the Company or any of its Restricted Subsidiaries to be, established after the Original Issue Date, (ii) that is incorporated in any jurisdiction other than the PRC and (iii) in respect of which the Company or any of its Restricted Subsidiaries is proposing to sell, whether through the sale of existing shares or the issuance of new shares, no less than 20% and no more than 49.9% of the Capital Stock of such Restricted Subsidiary, the Company may, concurrently with the consummation of such sale or issuance, provide a JV Subsidiary Guarantee (as defined below) instead of a Subsidiary Guarantee for (a) such Restricted Subsidiary and (b) the Restricted Subsidiaries of such Restricted Subsidiary that are organized in any jurisdiction other than the PRC, if the following conditions, in the case of both (a) and (b), are satisfied:

- as of the date of execution of the JV Subsidiary Guarantee (as defined below), no document exists that is binding on the Company or any of the Restricted Subsidiaries that would have the effect of (a) prohibiting the Company or any of the Restricted Subsidiaries from providing such JV Subsidiary Guarantee or (b) requiring the Company or any of the Restricted Subsidiaries to deliver or keep in place a guarantee on terms that are more favorable to the recipients of such guarantee than the JV Subsidiary Guarantee;
- such sale or issuance of Capital Stock is made to an Independent Third Party at a consideration that is not less than the appraised value of such Capital Stock by an independent appraisal firm of recognized international standing appointed by the Company;
- as of the date of execution of the JV Subsidiary Guarantee, after giving effect to the issuance or sale of Capital Stock in such JV Subsidiary Guarantor, the Non-Guaranteed Portion (as defined below) with respect to all of the JV Subsidiary Guarantors then existing and their respective Restricted Subsidiaries does not exceed 10.0% of Total Assets;
- all capital contributions (by way of transfer of cash or other property or any payment for property or services for the use of others or otherwise) to be made into a JV Subsidiary Guarantor from the date of the sale of existing Capital Stock or issuance of new Capital Stock as referred to above, shall be made directly or by contribution of assets or services having an equivalent Fair Market Value by (i) the Company and its Restricted Subsidiaries and (ii) such Independent Third Party that purchased or subscribed for Capital Stock in the JV Subsidiary Guarantor in proportion to their respective direct or indirect ownership percentages of the Capital Stock of such JV Subsidiary Guarantor;

- concurrently with providing the JV Subsidiary Guarantee, the Company shall or shall cause such JV Subsidiary Guarantor to deliver to the Trustee:
  - (i) (A) a duly executed JV Subsidiary Guarantee of such JV Subsidiary Guarantor (the “JV Subsidiary Guarantee”) and each Restricted Subsidiary of such JV Subsidiary Guarantor that is not organized under the laws of the PRC, and (B) a duly executed supplemental indenture to the Indenture pursuant to which such JV Subsidiary Guarantor will guarantee the payment of the Notes, each of which provides, among other things, that the aggregate claims of the Trustee under such JV Subsidiary Guarantee and all JV Subsidiary Guarantees provided by the Restricted Subsidiaries and shareholders of such JV Subsidiary Guarantor will be limited to the JV Entitlement Amount;
  - (ii) a duly executed Security Document that pledges in favor of the Collateral Agent for itself and for the benefit of the Trustee the Capital Stock of such JV Subsidiary Guarantor held by the Company or any Subsidiary Guarantor, but not the Capital Stock of the direct or indirect Subsidiaries of such JV Subsidiary Guarantor;
  - (iii) an Officers’ Certificate certifying a copy of the Board Resolution to the effect that such JV Subsidiary Guarantee has been approved by a majority of the disinterested members of the Board of Directors; and
  - (iv) a legal opinion by a law firm of recognized international standing confirming that under New York law such JV Subsidiary Guarantees are valid, binding and enforceable against the JV Subsidiary Guarantors providing such JV Subsidiary Guarantees (subject to customary qualifications and assumptions).

As of December 31, 2012, the Company and its consolidated subsidiaries had total debt (other than the 2010 Notes and the 2012 Notes) of approximately RMB5,554.0 million (US\$891.5 million), of which approximately RMB3,951.7 million (US\$634.3 million) was secured.

As of December 31, 2012, the Non-Guarantor Subsidiaries had total liabilities of approximately RMB17,262.5 million (US\$2,770.7 million) and the Non-Guarantor Subsidiaries had capital commitments of approximately RMB4,811.2 million (US\$772.3 million) and contingent liabilities of approximately RMB2,750.8 million (US\$441.5 million).

The Subsidiary Guarantee of each Subsidiary Guarantor:

- is a general obligation of such Subsidiary Guarantor;
- is effectively subordinated to other secured obligations (if any) of such Subsidiary Guarantor, to the extent of the value of the assets serving as security therefor (other than the Collateral);
- is senior in right of payment to all future obligations of such Subsidiary Guarantor expressly subordinated in right of payment to such Subsidiary Guarantee; and
- ranks at least *pari passu* with all other unsecured, unsubordinated Indebtedness of such Subsidiary Guarantor (subject to any priority rights of such unsubordinated Indebtedness pursuant to applicable law).

If any is provided, the JV Subsidiary Guarantee of each JV Subsidiary Guarantor:

- will be a general obligation of such JV Subsidiary Guarantor;
- will be enforceable only up to the JV Entitlement Amount;
- will be effectively subordinated to secured obligations (if any) of such JV Subsidiary Guarantor, to the extent of the value of the assets serving as security therefor;

- will be limited to the JV Entitlement Amount, and will be senior in right of payment to all future obligations of such JV Subsidiary Guarantor expressly subordinated in right of payment to such JV Subsidiary Guarantee; and
- will be limited to the JV Entitlement Amount, and will rank at least *pari passu* with all other unsecured, unsubordinated Indebtedness of such JV Subsidiary Guarantor (subject to any priority rights of such unsubordinated Indebtedness pursuant to applicable law).

The Company will cause each of its future Restricted Subsidiaries (other than Persons organized under the laws of the PRC), promptly upon becoming a Restricted Subsidiary, to execute and deliver to the Trustee a supplemental indenture to the Indenture pursuant to which such Restricted Subsidiary will Guarantee the payment of the Notes as either a Subsidiary Guarantor or a JV Subsidiary Guarantor. Notwithstanding the foregoing, the Company may elect to have any future Restricted Subsidiary (and its Restricted Subsidiaries) organized outside the PRC not provide a Subsidiary Guarantee or JV Subsidiary Guarantee at the time such entity becomes a Restricted Subsidiary (the “New Non-Guarantor Subsidiaries,” together with the Initial Non-Guarantor Subsidiaries, the “Other Non-Guarantor Subsidiaries”), *provided* that, after giving effect to the Consolidated Assets of such Restricted Subsidiary, the Consolidated Assets of all Restricted Subsidiaries organized outside the PRC that are not Subsidiary Guarantors or JV Subsidiary Guarantors do not account for more than 10% of the Total Assets of the Company.

In the case of a Subsidiary Guarantor with respect to which the Company or any of its Restricted Subsidiaries is proposing to sell, whether through the sale of existing shares or the issuance of new shares, no less than 20% of the Capital Stock of such Subsidiary Guarantor, the Company may concurrently with the consummation of such sale or issuance of Capital Stock, (a) instruct the Trustee to release the Subsidiary Guarantees provided by such Subsidiary Guarantor and each of its Restricted Subsidiaries organized outside the PRC, and upon such release such Subsidiary Guarantor and its Restricted Subsidiaries organized outside the PRC will become New Non-Guarantor Subsidiaries (such that each New Non-Guarantor Subsidiary will no longer Guarantee the Notes) and (b) instruct the Collateral Agent to (i) discharge the pledge of the Capital Stock granted by each such New Non-Guarantor Subsidiary and (ii) discharge the pledge of Capital Stock made by the Company or any Subsidiary Guarantor over the shares it owns in each such New Non-Guarantor Subsidiary (in each case, without any requirement to seek the consent or approval of the Holders of the Notes), *provided* that after the release of such Subsidiary Guarantees, the Consolidated Assets of all Restricted Subsidiaries organized outside the PRC that are not Subsidiary Guarantors or JV Subsidiary Guarantors (including the New Non-Guarantor Subsidiaries) do not account for more than 10% of the Total Assets of the Company. A Subsidiary Guarantee of a Subsidiary Guarantor may only be released pursuant to this paragraph if as of the date of such proposed release, no document exists that is binding on the Company or any of the Restricted Subsidiaries that would have the effect of (a) prohibiting the Company or any of the Restricted Subsidiaries from releasing such Subsidiary Guarantee or (b) requiring the Company or such Subsidiary Guarantor to deliver or keep in place a guarantee of other Indebtedness of the Company by such Subsidiary Guarantor.

Each Restricted Subsidiary that guarantees the Notes after the Original Issue Date other than a JV Subsidiary Guarantee is referred to as a “Future Subsidiary Guarantor” and upon execution of the applicable supplemental indenture to the Indenture will be a “Subsidiary Guarantor.” The Other Non-Guarantor Subsidiaries, together with the PRC Non-Guarantor Subsidiaries, are referred to herein as the “Non-Guarantor Subsidiaries.”

Although the Indenture contains limitations on the amount of additional Indebtedness that Restricted Subsidiaries organized under the laws of the PRC may incur, the amount of such additional Indebtedness could be substantial. In the event of a bankruptcy, liquidation or reorganization of any Non-Guarantor Subsidiary, the Non-Guarantor Subsidiaries will pay the holders of their debt and their trade creditors before they will be able to distribute any of their assets to the Company.

In addition, subject to the limitations described in “Risk Factors — Risks Relating to the Subsidiary Guarantees, the JV Subsidiary Guarantees and the Collateral,” the Subsidiary Guarantee of each Subsidiary Guarantor Pledgor:

- will be entitled to the benefit of a security interest in the Collateral (subject to any Permitted Liens) pledged by such Subsidiary Guarantor Pledgor, as described below under the caption “— Security” shared on a *pari passu* basis pursuant to the Intercreditor Agreement (as defined below) with (i) holders of the 2010 Notes; (ii) holders of the 2012 Notes; (iii) holders of the January 2013 Notes; and (iv) holders of other Permitted *Pari Passu* Secured Indebtedness; and
- will rank effectively senior in right of payment to the unsecured obligations of such Subsidiary Guarantor Pledgor with respect to the value of the Collateral securing such Subsidiary Guarantee (subject to any priority rights of such unsecured obligations pursuant to applicable law).

The JV Subsidiary Guarantee of each JV Subsidiary Guarantor will not be secured.

Under the Indenture, and any supplemental indenture to the Indenture, as applicable, each of the Subsidiary Guarantors and JV Subsidiary Guarantors (if any) will jointly and severally guarantee the due and punctual payment of the principal of, premium, if any, and interest on, and all other amounts payable under, the Notes; *provided* that any JV Subsidiary Guarantee will be limited to the JV Entitlement Amount. The Subsidiary Guarantors and JV Subsidiary Guarantors will (1) agree that their respective obligations under the Subsidiary Guarantees and JV Subsidiary Guarantees, as the case may be, will be enforceable irrespective of any invalidity, irregularity or unenforceability of the Notes or the Indenture and (2) waive their right to require the Trustee to pursue or exhaust its legal or equitable remedies against the Company prior to exercising its rights under the Subsidiary Guarantees and the JV Subsidiary Guarantees, as the case may be. Moreover, if at any time any amount paid under a Note or the Indenture is rescinded or must otherwise be restored, the rights of the Holders under the Subsidiary Guarantees and the JV Subsidiary Guarantees, as the case may be, will be reinstated with respect to such payment as though such payment had not been made. All payments under the Subsidiary Guarantees and the JV Subsidiary Guarantees, as the case may be, are required to be made in Renminbi.

Under the Indenture, and any supplemental indenture to the Indenture, as applicable,

- each Subsidiary Guarantee will be limited to an amount not to exceed the maximum amount that can be guaranteed by the applicable Subsidiary Guarantor without rendering the Subsidiary Guarantee, as it relates to such Subsidiary Guarantor, voidable under applicable law relating to fraudulent conveyance or fraudulent transfer or similar laws affecting the rights of creditors generally; and
- each JV Subsidiary Guarantee will be limited to an amount which is the lower of (i) the JV Entitlement Amount and (ii) an amount not to exceed the maximum amount that can be guaranteed by the applicable JV Subsidiary Guarantor without rendering the JV Subsidiary Guarantee, as it relates to such JV Subsidiary Guarantor, voidable under applicable law relating to fraudulent conveyance or fraudulent transfer or similar laws affecting the rights of creditors generally.

If a Subsidiary Guarantee or JV Subsidiary Guarantee were to be rendered voidable, it could be subordinated by a court to all other Indebtedness (including guarantees and other contingent liabilities) of the applicable Subsidiary Guarantor or JV Subsidiary Guarantor, as the case may be, and, depending on the amount of such Indebtedness, a Subsidiary Guarantor’s liability on its Subsidiary Guarantee or a JV Subsidiary Guarantor’s liability on its JV Subsidiary Guarantee, as the case may be, could in each case be reduced to zero.

The obligations of each Subsidiary Guarantor under its Subsidiary Guarantee and the enforceability of the Collateral granted in respect of the Subsidiary Guarantees of the Subsidiary Guarantor Pledgors may be limited, or possibly invalid, under applicable laws. Similarly, the obligations of each JV Subsidiary Guarantor under its JV Subsidiary Guarantee may be limited, or possibly invalid, under



applicable laws. See “Risk Factors — Risks Relating to the Subsidiary Guarantees, the JV Subsidiary Guarantees and the Collateral — The Subsidiary Guarantees or JV Subsidiary Guarantees may be challenged under applicable insolvency or fraudulent transfer laws, which could impair the enforceability of the Subsidiary Guarantees or JV Subsidiary Guarantees.”

### ***Release of the Subsidiary Guarantees***

A Subsidiary Guarantee given by a Subsidiary Guarantor and a JV Subsidiary Guarantee given by a JV Subsidiary Guarantor may be released in certain circumstances, including:

- upon repayment in full of the Notes;
- upon a defeasance as described under “— Defeasance — Defeasance and Discharge;”
- upon the designation by the Company of a Subsidiary Guarantor or a JV Subsidiary Guarantor, as the case may be, as an Unrestricted Subsidiary in compliance with the terms of the Indenture;
- upon the sale of a Subsidiary Guarantor or a JV Subsidiary Guarantor, as the case may be, in compliance with the terms of the Indenture (including the covenants under the captions “— Certain Covenants — Limitation on Sales and Issuances of Capital Stock in Restricted Subsidiaries,” “— Certain Covenants — Limitation on Asset Sales” and “— Consolidation, Merger and Sale of Assets”) resulting in such Subsidiary Guarantor or JV Subsidiary Guarantor, as the case may be, no longer being a Restricted Subsidiary, so long as (1) such Subsidiary Guarantor or JV Subsidiary Guarantor, as the case may be, is simultaneously released from its obligations in respect of any of the Company’s other Indebtedness or any Indebtedness of any other Restricted Subsidiary and (2) the proceeds from such sale or disposition are used for the purposes permitted or required by the Indenture;
- upon the replacement of a Subsidiary Guarantee with a JV Subsidiary Guarantee; or
- in the case of a Subsidiary Guarantor that becomes a New Non-Guarantor Subsidiary, in compliance with the terms of the Indenture.

### ***Replacement of Subsidiary Guarantees with JV Subsidiary Guarantees***

A Subsidiary Guarantee given by a Subsidiary Guarantor may be released following the sale or issuance by the Company or any of its Restricted Subsidiaries of Capital Stock in (a) such Subsidiary Guarantor or (b) any other Subsidiary Guarantor that, directly or indirectly, owns a majority of the Capital Stock of such Subsidiary Guarantor, in each case where such sale or issuance, whether through the sale of existing shares or the issuance of new shares, is for no less than 20% and no more than 49.9% of the issued Capital Stock of the relevant Subsidiary Guarantor, *provided* that the following conditions are satisfied or complied with:

- as of the date of such proposed release, no document exists that is binding on the Company or any of the Restricted Subsidiaries that would have the effect of (a) prohibiting the Company or any of the Restricted Subsidiaries from releasing such Subsidiary Guarantee, (b) prohibiting the Company or any of the Restricted Subsidiaries from providing such JV Subsidiary Guarantee, or (c) requiring the Company or any of the Restricted Subsidiaries to deliver or keep in force a replacement guarantee on terms that are more favorable to the recipients of such guarantee than the JV Subsidiary Guarantee;
- such sale is made to an Independent Third Party at a consideration that is not less than the appraised value of such Capital Stock by an independent appraisal firm of recognized international standing appointed by the Company;
- as of the date of execution of the JV Subsidiary Guarantee, after giving effect to the issuance or sale of Capital Stock in such JV Subsidiary Guarantor, the Non-Guaranteed Portion with

respect to all of the JV Subsidiary Guarantors then existing and their respective Restricted Subsidiaries does not exceed 10.0% of Total Assets;

- all capital contributions (by way of transfer of cash or other property or any payment for property or services for the use of others or otherwise) to be made into a JV Subsidiary Guarantor from the date of the sale of existing Capital Stock or issuance of new Capital Stock as referred to above, shall be made directly or by contribution of assets or services having an equivalent Fair Market Value by (i) the Company and its Restricted Subsidiaries and (ii) such Independent Third Party that purchased or subscribed for Capital Stock in the JV Subsidiary Guarantor in proportion to their respective direct or indirect ownership percentages of the Capital Stock of such JV Subsidiary Guarantor;
- concurrently with the release of such Subsidiary Guarantee, the Company shall or shall cause such JV Subsidiary Guarantor to deliver to the Trustee:
  - (i) (A) a duly executed JV Subsidiary Guarantee of such JV Subsidiary Guarantor and each Restricted Subsidiary of such JV Subsidiary Guarantor that is not organized under the laws of the PRC and (B) a duly executed supplemental indenture to the Indenture pursuant to which such JV Subsidiary Guarantor will guarantee the payment of the Notes, each of which provides, among other things, that the aggregate claims of the Trustee under such JV Subsidiary Guarantee and all JV Subsidiary Guarantees provided by the Restricted Subsidiaries and shareholders of such JV Subsidiary Guarantor will be limited to the JV Entitlement Amount;
  - (ii) a duly executed Security Document that pledges in favor of the Collateral Agent the Capital Stock of such JV Subsidiary Guarantor held by the Company or any Subsidiary Guarantor, but not the Capital Stock of the direct or indirect Subsidiaries of such JV Subsidiary Guarantor;
  - (iii) an Officers' Certificate certifying a copy of a Board Resolution to the effect that such JV Subsidiary Guarantee has been approved by a majority of the disinterested members of the Board of Directors; and
  - (iv) a legal opinion by a law firm of recognized international standing confirming that under New York law such JV Subsidiary Guarantee is valid, binding and enforceable against the JV Subsidiary Guarantor providing such JV Subsidiary Guarantee (subject to customary qualifications and assumptions).

Notwithstanding the foregoing paragraph, any such sale or issuance of the Capital Stock of the relevant Subsidiary Guarantor (including where such sale results in the relevant Subsidiary Guarantor ceasing to be a Restricted Subsidiary) will need to comply with the other covenants set forth in the Indenture, including, without limitation, the "Limitation on Asset Sales" and "Limitation on Restricted Payments" covenants.

Any Net Cash Proceeds from the sale of such Capital Stock shall be applied by the Company (or any Restricted Subsidiary) in accordance with the "Limitation on Asset Sales" covenant.

As of the date of the Indenture, all of the Company's Subsidiaries will be "Restricted Subsidiaries" except those listed under "— Definitions — Unrestricted Subsidiary." Under the circumstances described below under the caption "— Certain Covenants — Designation of Restricted and Unrestricted Subsidiaries," the Company will be permitted to designate certain of its Subsidiaries as "Unrestricted Subsidiaries." The Company's Unrestricted Subsidiaries will generally not be subject to the restrictive covenants in the Indenture. The Company's Unrestricted Subsidiaries will not Guarantee the Notes.

## **Security**

The Company has pledged, or caused the initial Subsidiary Guarantor Pledgors to pledge, as the case may be, the Capital Stock of the initial Subsidiary Guarantors (the "Collateral") (subject to Permitted

Liens and the Intercreditor Agreement) on the Original Issue Date in order to secure the obligations of the Company under the 2010 Notes and related Subsidiary Guarantees, the 2012 Notes and related Subsidiary Guarantees, the January 2013 Notes and related Subsidiary Guarantees, the Notes and the Subsidiary Guarantees and other Permitted *Pari Passu* Secured Indebtedness.

The initial Subsidiary Guarantor Pledgors are Fantastic Victory Limited, Wisdom Regal Limited and Fantasia Financial Holdings Group Co., Ltd (formerly known as “Strong Nova Holdings Limited”).

None of the Capital Stock of the Non-Guarantor Subsidiaries will be pledged on the Original Issue Date or at any time in the future. In addition, none of the Capital Stock of any future Restricted Subsidiary that may be organized under the laws of the PRC will be pledged at any time in the future. If any JV Subsidiary Guarantor is established, the Capital Stock of such JV Subsidiary Guarantor owned by the Company or any Subsidiary Guarantor will be pledged to secure the obligations of the Company under the Notes and the Indenture, and of such Subsidiary Guarantor under its Subsidiary Guarantee, as the case may be, in the manner described above. However, none of the JV Subsidiary Guarantors will provide a Security Document pledging the Capital Stock of its direct or indirect Subsidiaries as security in favor of the Collateral Agent for itself and for the benefit of the Trustee.

The Company has also agreed, for the benefit of the Holders, to pledge, or cause each Subsidiary Guarantor (other than a JV Subsidiary Guarantor, if any) to pledge, the Capital Stock owned by the Company or such Subsidiary Guarantor of any Person that becomes a Restricted Subsidiary or additional shares of Capital Stock acquired or otherwise received by the Company or such Subsidiary Guarantor of any existing Restricted Subsidiary (in each case, other than Persons organized under the laws of the PRC or Other Non-Guarantor Subsidiaries) after the Original Issue Date, promptly upon such Person becoming a Restricted Subsidiary, to secure the obligations of the Company under the Notes and the Indenture, and of such Subsidiary Guarantor under its Subsidiary Guarantee, in the manner described above. The Collateral will be shared on a *pari passu* basis pursuant to the Intercreditor Agreement (as defined below) by the holders of the Notes, the holders of the 2010 Notes, the holders of the 2012 Notes, the holders of the January 2013 Notes and the holders of other Permitted *Pari Passu* Secured Indebtedness. Accordingly, in the event of a default on the Notes or the other secured indebtedness and a foreclosure on the Collateral, any foreclosure proceeds would be shared by the holders of secured indebtedness in proportion to the outstanding amounts of each class of secured indebtedness.

Each Subsidiary Guarantor that pledges capital stock of a Restricted Subsidiary after the Original Issue Date is referred to as a “Future Subsidiary Guarantor Pledgor” and, upon giving such pledge, will be a “Subsidiary Guarantor Pledgor.”

The value of the Collateral securing the Notes and the Subsidiary Guarantees of the Subsidiary Guarantor Pledgors (as reduced by the obligations owed to other secured creditors under the Intercreditor Agreement) is unlikely to be sufficient to satisfy the Company’s and each of the Subsidiary Guarantor Pledgors’ obligations under the Notes and the Subsidiary Guarantees of the Subsidiary Guarantor Pledgors (as reduced by the obligations owed to other secured creditors under the Intercreditor Agreement), and the Collateral securing the Notes and such Subsidiary Guarantee (as reduced by the obligations owed to other secured creditors under the Intercreditor Agreement) may be reduced or diluted under certain circumstances, including the issuance of Additional Notes and other Permitted *Pari Passu* Secured Indebtedness and the disposition of assets comprising the Collateral, subject to the terms of the Indenture. See “— Release of Security” and “Risk Factors — Risks Relating to the Subsidiary Guarantees, the JV Subsidiary Guarantees and the Collateral — The value of the Collateral is unlikely to be sufficient to satisfy our obligations under the Notes and other *pari passu* secured indebtedness.”

No appraisals of the Collateral have been prepared in connection with this offering of the Notes. There can be no assurance that the proceeds of any sale of the Collateral, in whole or in part, pursuant to the Indenture, the Intercreditor Agreement and the Security Documents following an Event of Default, would be sufficient to satisfy amounts due on the Notes or the Subsidiary Guarantees of the Subsidiary Guarantor Pledgors (as reduced by the obligations owed to other secured creditors under the Intercreditor Agreement). By its nature, some or all of the Collateral will be illiquid and may have no readily ascertainable market value. Accordingly, there can be no assurance that the Collateral would be sold in a timely manner or at all.

So long as no Payment Default has occurred and is continuing, and subject to the terms of the Security Documents and the Indenture, the Company and the Subsidiary Guarantor Pledgors, as the case may be, will be entitled to exercise any and all voting rights and to receive, retain and use any and all cash dividends, stock dividends, liquidating dividends, non-cash dividends, shares or stock resulting from stock splits or reclassifications, rights issues, warrants, options and other distributions (whether similar or dissimilar to the foregoing) in respect of Capital Stock constituting Collateral.

#### ***Permitted Pari Passu Secured Indebtedness***

On or after the Original Issue Date, the Company and each Subsidiary Guarantor Pledgor may create Liens on the Collateral *pari passu* with the Lien for the benefit of the Holders to secure Indebtedness of the Company (including Additional Notes) and any Pari Passu Subsidiary Guarantee of a Subsidiary Guarantor Pledgor with respect to such Indebtedness (such Indebtedness of the Company and any such Pari Passu Subsidiary Guarantee, “Permitted Pari Passu Secured Indebtedness”); *provided* that (1) the Company or such Subsidiary Guarantor Pledgor was permitted to Incur such Indebtedness under the covenant under the caption “— Limitation on Indebtedness and Preferred Stock,” (2) the holders of such Indebtedness (or their representative) become party to the Intercreditor Agreement referred to below; (3) the agreement in respect of such Indebtedness contains provisions with respect to releases of Collateral and such Pari Passu Subsidiary Guarantee is substantially similar to and no more restrictive on the Company and such Subsidiary Guarantor Pledgor than the provisions of the Indenture and the Security Documents; and (4) the Company and such Subsidiary Guarantor Pledgor deliver to the Trustee an Opinion of Counsel and Officers’ Certificate with respect to corporate and collateral matters in connection with the Security Documents, in form and substance as set forth in the Security Documents. The Trustee will be permitted and authorized, without the consent of any Holder, to enter into any amendment to the Security Documents, the Intercreditor Agreement or the Indenture and take any other action necessary to permit the creation and registration of Liens on the Collateral to secure Permitted Pari Passu Secured Indebtedness in accordance with this paragraph and the terms of the Indenture (including, without limitation, the appointment of any collateral agent under the Intercreditor Agreement referred to below to hold the Collateral on behalf of the Holders, the holders of the 2010 Notes, the holders of the 2012 Notes, the holders of the January 2013 Notes and the holders of Permitted Pari Passu Secured Indebtedness).

Except for certain Permitted Liens and the Permitted Pari Passu Secured Indebtedness, the Company and its Restricted Subsidiaries will not be permitted to issue or Incur any other Indebtedness secured by all or any portion of the Collateral without the consent of each Holder of the Notes then outstanding.

#### ***Intercreditor Agreement***

The Company, the initial Subsidiary Guarantor Pledgors, Citicorp International Limited, as collateral agent (the “Collateral Agent”), Citicorp International Limited, as trustee with respect to the 2010 Notes and Citicorp International Limited, as trustee with respect to the 2012 Notes have entered into an intercreditor agreement (to which Citicorp International Limited, as trustee with respect to the January 2013 Notes acceded on January 22, 2013; as so amended, supplemented or modified from time to time, the “Intercreditor Agreement”) dated as of September 27, 2012. The Trustee will accede to the Intercreditor Agreement on the Original Issue Date, pursuant to which the Trustee will agree to (1) share equal priority and *pro rata* entitlement in and to the Collateral; (2) the conditions that are applicable to the release of or granting of any Lien on such Collateral; and (3) the conditions under which they will enforce their respective rights with respect to such Collateral and the Indebtedness secured thereby.

In connection with the Incurrence of any future Permitted Pari Passu Secured Indebtedness (other than Additional Notes), the holders of such Permitted Pari Passu Secured Indebtedness (or their representative) will accede to the Intercreditor Agreement to include the holders (or their representatives or agents) of such Permitted Pari Passu Secured Indebtedness as parties to the Intercreditor Agreement.

By accepting the Notes, each Holder shall be deemed to have consented to the execution of the Intercreditor Agreement, any supplements, amendments or modifications thereto, and any future intercreditor agreement that may be required under the terms of the Indenture.

### *Enforcement of Security*

The Liens (subject to Permitted Liens) securing the Notes and the Subsidiary Guarantees of the Subsidiary Guarantor Pledgors have been granted to the Collateral Agent for itself and for the benefit of the Trustee, the trustee for the 2010 Notes, the trustee for the 2012 Notes and the trustee for the January 2013 Notes. The Collateral Agent, subject to the Intercreditor Agreement, will hold such Liens and security interests in the Collateral granted pursuant to the Security Documents with sole authority as directed by the written instruction of the Holders to exercise remedies under the Security Documents. The Trustee has agreed to act as secured party on behalf of the holders under the applicable Security Documents, to follow, or cause to be followed, the instructions provided to it under the Indenture, the Intercreditor Agreement and the Security Documents and to carry out certain other duties.

The Indenture, the Intercreditor Agreement and/or the Security Documents principally provide that, at any time while the Notes are outstanding, the Collateral Agent has the right to manage, perform and enforce the terms of the Security Documents relating to the Collateral and to exercise and enforce privileges, rights and remedies thereunder according to its direction, including to take or retake control or possession of such Collateral and to hold, prepare for sale, process, lease, dispose of or liquidate such Collateral, including, without limitation, following the occurrence of an Event of Default under the Indenture.

The Intercreditor Agreement will provide that the Collateral Agent will enforce the Collateral in accordance with a written instruction by any Secured Parties Representative to do so if it does not identify a conflict between the Secured Parties' interests or a conflict between instructions (in the event at least two Secured Parties issue instructions), and in the case of conflicting instructions delivered by two or more Secured Parties Representatives, the Collateral Agent will only enforce the Collateral upon receiving written instructions from the holders of a majority of the outstanding principal amount of the Indebtedness secured by the Collateral. See "Risk Factors — Risks Relating to the Subsidiary Guarantees and the Collateral — The Intercreditor Agreement may limit the rights of holders of the Notes to enforce the Collateral."

All payments received and all amounts held by the Collateral Agent in respect of the Collateral under the Security Documents will be, subject to the Intercreditor Agreement, applied as follows:

*first*, to the Collateral Agent to the extent necessary to reimburse the Collateral Agent for any expenses (including reasonable expenses of its counsel) incurred in connection with the collection or distribution of such amounts held or realized or in connection with expenses incurred in enforcing all available remedies under the Intercreditor Agreement and the Security Documents and preserving the Collateral and all amounts for which the Collateral Agent is entitled to indemnification under the Intercreditor Agreement and the Security Documents;

*second*, to the extent not reimbursed under the above paragraph, to the Trustee, the trustee for the 2010 Notes, the trustee for the 2012 Notes, the trustee for the January 2013 Notes and other Secured Parties Representatives, to the extent necessary to reimburse the foregoing persons ratably for any unpaid fees, costs and expenses (including expenses of any paying agents, transfer agents, registrars or other agents in connection therewith appointed in connection with the foregoing and reasonable expenses of counsel) incurred under the Security Documents and the agreement governing the Notes, the 2010 Notes, the 2012 Notes, the January 2013 Notes or any Permitted Pari Passu Secured Indebtedness (or any other document in connection with the foregoing that such paying agents, transfer agents, registrars or other agents are party to) in connection with the collection or distribution of such amounts held or realized or in connection with expenses incurred in enforcing all available remedies under the Notes, the 2010 Notes, the 2012 Notes, the January 2013 Notes and the agreements governing the Notes, the 2010 Notes, the 2012 Notes, the January 2013 Notes or any Permitted Pari Passu Secured Indebtedness, the Intercreditor Agreement, the Security Documents and preserving the Collateral and all indemnification payments for which the foregoing persons are entitled to under the Notes, the 2010 Notes, the 2012 Notes, the January 2013 Notes and the agreement governing the Notes, the 2010 Notes, the 2012 Notes, the January 2013 Notes or any Permitted Pari Passu Secured Indebtedness, the Intercreditor Agreement and the Security Documents;

*third*, ratably to each of the trustee for the 2010 Notes for the benefit of the holders of the 2010 Notes, the trustee for the 2012 Notes for the benefit of the holders of the 2012 Notes, the trustee for the January 2013 Notes for the benefit of the holders of the January 2013 Notes and the Trustee for the benefit of the holders of the Notes and, to the extent applicable, to other Secured Parties for the benefit of the holders of any Permitted Pari Passu Secured Indebtedness (to the extent not paid pursuant to the paragraphs above), inclusive of any reasonable fees and expenses of the foregoing persons and the principal, interest and premium thereon and for the benefit of the holders each thereof in accordance with the terms of the Notes, the 2010 Notes, the 2012 Notes, the January 2013 Notes or the agreement governing the Notes, the 2010 Notes, the 2012 Notes, the January 2013 Notes or any Permitted Pari Passu Secured Indebtedness; and

*fourth*, any surplus remaining after such payments will be paid to the Company, the Subsidiary Guarantor Pledgors or to whomever may be lawfully entitled thereto.

The Collateral Agent may decline to foreclose on the Collateral or exercise remedies available if it does not receive indemnification to its satisfaction. In addition, the Collateral Agent's ability to foreclose on the Collateral may be subject to lack of perfection, the consent of third parties, prior Liens and practical problems associated with the realization of the Collateral Agent's Liens on the Collateral. Neither the Collateral Agent nor any of its officers, directors, employees, attorneys or agents will be responsible or liable for the existence, genuineness, value or protection of any Collateral securing the Notes, for the legality, enforceability, effectiveness or sufficiency of the Security Documents, for the creation, perfection, continuation, priority, sufficiency or protection of any of the Liens, for any defect or deficiency as to any such matters, or for any failure to demand, collect, foreclose or realize upon or otherwise enforce any of the Liens or Security Documents or any delay in doing so.

The Security Documents provide that the Company and the Subsidiary Guarantor Pledgors will indemnify the Collateral Agent for all liabilities, obligations, losses, damages, penalties, actions, judgments, suits, costs, expenses or disbursements of any kind imposed against the Collateral Agent arising out of the Security Documents except to the extent that any of the foregoing are finally judicially determined to have resulted from the gross negligence or willful misconduct of the Collateral Agent.

This section, "— Enforcement of Security," shall be subject to any amendments to the Security Documents or the Indenture to permit the creation of Liens on the Collateral to secure Permitted Pari Passu Secured Indebtedness in accordance with "— Permitted Pari Passu Secured Indebtedness" above.

### ***Release of Security***

The security created in respect of the Collateral granted under the Security Documents may be released in certain circumstances, including:

- upon repayment in full of the Notes;
- upon defeasance and discharge of the Notes as provided below under the caption "— Defeasance — Defeasance and Discharge;"
- upon certain dispositions of the Collateral in compliance with the covenants under the captions "— Limitation on Sales and Issuances of Capital Stock in Restricted Subsidiaries" or "— Limitation on Asset Sales" or in accordance with the provision under the caption "— Consolidation, Merger and Sale of Assets;"
- with respect to security granted by a Subsidiary Guarantor Pledgor, upon the release of the Subsidiary Guarantee of such Subsidiary Guarantor Pledgor in accordance with the terms of the Indenture;
- in connection with and upon execution of a JV Subsidiary Guarantee to replace a Subsidiary Guarantee, with respect to all pledges of Capital Stock granted by such JV Subsidiary Guarantor in its direct and indirect Subsidiaries, and in accordance with the terms of the Indenture; or

- with respect to a Subsidiary Guarantor that becomes a New Non-Guarantor Subsidiary, the release of the pledge of Capital Stock made by the Company or any Subsidiary Guarantor over the shares it owns in such New Non-Guarantor Subsidiary.

### **Further Issues**

Subject to the covenants described below and in accordance with the terms of the Indenture, the Company may, from time to time, without notice to or the consent of the Holders, create and issue Additional Notes having the same terms and conditions as the Notes (including the benefit of the Subsidiary Guarantees and JV Subsidiary Guarantees) in all respects (or in all respects except for the issue date, issue price and the first payment of interest on them and, to the extent necessary, certain temporary securities law transfer restrictions) (a “Further Issue”) so that such Additional Notes may be consolidated and form a single class with the previously outstanding Notes and vote together as one class on all matters with respect to the Notes; *provided* that the issuance of any such Additional Notes shall then be permitted under the “Limitation on Indebtedness and Preferred Stock” covenant described below.

### **Optional Redemption**

At any time prior to maturity, the Company may at its option redeem the Notes, in whole but not in part, at a redemption price equal to 100% of the principal amount of the Notes plus the Applicable Premium as of, and accrued and unpaid interest, if any, to (but not including) the redemption date. The Company will give not less than 30 days’ nor more than 60 days’ notice of any redemption.

At any time and from time to time prior to maturity, the Company may redeem up to 35% of the aggregate principal amount of the Notes with the Net Cash Proceeds of one or more sales of Common Stock of the Company in an Equity Offering at a redemption price of 107.875% of the principal amount of the Notes, plus accrued and unpaid interest, if any, to (but not including) the redemption date; *provided* that at least 65% of the aggregate principal amount of the Notes issued on the Original Issue Date remains outstanding after each such redemption and any such redemption takes place within 60 days after the closing of the related Equity Offering.

### ***Selection and Notice***

The Company will give not less than 30 days’ nor more than 60 days’ notice of any redemption. If less than all of the Notes are to be redeemed at any time, the Trustee will select Notes for redemption as follows:

- (1) if the Notes are listed on any national securities exchange, in compliance with the requirements of the principal national securities exchange on which the Notes are listed; or
- (2) if the Notes are not listed on any national securities exchange or if there is no applicable requirement of the principal stock exchange on which the Notes are listed, in compliance with the requirements of the clearing systems if the Notes are held through any clearing systems, on a pro rata basis, by lot or by such method as the Trustee deems fair and appropriate.

A Note of CNY1,000,000 in principal amount or less shall not be redeemed in part. If any Note is to be redeemed in part only, the notice of redemption relating to such Note will state the portion of the principal amount to be redeemed. A new Note in principal amount equal to the unredeemed portion will be issued upon cancellation of the original Note. On and after the redemption date, interest will cease to accrue on Notes or portions of them called for redemption.

### **Repurchase of Notes Upon a Change of Control Triggering Event**

Not later than 30 days following a Change of Control Triggering Event, the Company will make an Offer to Purchase all outstanding Notes (a “Change of Control Offer”) at a purchase price equal to 101% of the principal amount thereof plus accrued and unpaid interest, if any, to (but not including) the Offer to Purchase Payment Date.

The Company has agreed in the Indenture that it will timely repay all Indebtedness or obtain consents as necessary under, or terminate, agreements or instruments that would otherwise prohibit a Change of Control Offer required to be made pursuant to the Indenture. Notwithstanding this agreement of the Company, it is important to note that if the Company is unable to repay (or cause to be repaid) all of the Indebtedness, if any, that would prohibit repurchase of the Notes or is unable to obtain the requisite consents of the holders of such Indebtedness, or terminate any agreements or instruments that would otherwise prohibit a Change of Control Offer, it would continue to be prohibited from purchasing the Notes. In that case, the Company's failure to purchase tendered Notes would constitute an Event of Default under the Indenture.

Certain of the events constituting a Change of Control Triggering Event under the Notes will also constitute an event of default under certain debt instruments of the Company and its Subsidiaries. Future debt of the Company may also (1) prohibit the Company from purchasing Notes in the event of a Change of Control Triggering Event; (2) provide that a Change of Control Triggering Event is a default; or (3) require repurchase of such debt upon a Change of Control Triggering Event. Moreover, the exercise by the Holders of their right to require the Company to purchase the Notes could cause a default under other Indebtedness, even if the Change of Control Triggering Event itself does not, due to the financial effect of the purchase on the Company. The Company's ability to pay cash to the Holders following the occurrence of a Change of Control Triggering Event may be limited by the Company's and the Subsidiary Guarantors' then-existing financial resources. There can be no assurance that sufficient funds will be available when necessary to make the required purchase of the Notes. See "Risk Factors — Risks Relating to the Notes — We may not be able to repurchase the Notes upon a Change of Control Triggering Event."

The phrase "all or substantially all", as used with respect to the assets of the Company in the definition of "Change of Control," will likely be interpreted under applicable law of the relevant jurisdictions and will be dependent upon particular facts and circumstances. As a result, there may be a degree of uncertainty in ascertaining whether a sale or transfer of "all or substantially all" the assets of the Company has occurred.

Except as described above with respect to a Change of Control Triggering Event, the Indenture does not contain provisions that permit the Holders to require that the Company purchase or redeem the Notes in the event of a takeover, recapitalization or similar transaction.

### **No Mandatory Redemption or Sinking Fund**

There will be no mandatory redemption or sinking fund payments for the Notes.

### **Additional Amounts**

All payments of principal of, and premium (if any) and interest on the Notes or under the Subsidiary Guarantees and JV Subsidiary Guarantees will be made without withholding or deduction for, or on account of, any present or future taxes, duties, assessments or governmental charges of whatever nature imposed or levied by or within any jurisdiction in which the Company, a Surviving Person (as defined under the caption "— Consolidation, Merger and Sale of Assets") or an applicable Subsidiary Guarantor or JV Subsidiary Guarantor is organized or resident for tax purposes (or any political subdivision or taxing authority thereof or therein), including, without limitation, if applicable, the PRC (each, as applicable, a "Relevant Jurisdiction"), or the jurisdiction through which payments are made, unless such withholding or deduction is required by law or by regulation or governmental policy having the force of law. In the event that any such withholding or deduction is so required, the Company, a Surviving Person or the applicable Subsidiary Guarantor or JV Subsidiary Guarantor, as the case may be, will pay such additional amounts ("Additional Amounts") as will result in receipt by the Holder of each Note, the Subsidiary Guarantees or the JV Subsidiary Guarantees, as the case may be, of such amounts as would have been received by such Holder had no such withholding or deduction been required, except that no Additional Amounts shall be payable:

- (1) for or on account of:
  - (a) any tax, duty, assessment or other governmental charge that would not have been imposed but for:



- (i) the existence of any present or former connection between the Holder or beneficial owner of such Note, Subsidiary Guarantee or JV Subsidiary Guarantee, as the case may be, and the Relevant Jurisdiction or the jurisdiction through which payments are made, other than merely holding such Note or the receipt of payments thereunder or under a Subsidiary Guarantee or JV Subsidiary Guarantee, including, without limitation, such Holder or beneficial owner being or having been a national, domiciliary or resident of such Relevant Jurisdiction or treated as a resident thereof or being or having been physically present or engaged in a trade or business therein or having or having had a permanent establishment therein;
  - (ii) the presentation of such Note (in cases in which presentation is required) more than 30 days after the later of the date on which the payment of the principal of, premium, if any, and interest on, such Note became due and payable pursuant to the terms thereof or was made or duly provided for, except to the extent that the Holder thereof would have been entitled to such Additional Amounts if it had presented such Note for payment on any date within such 30-day period;
  - (iii) the failure of the Holder or beneficial owner to comply with a timely request of the Company, a Surviving Person, any Subsidiary Guarantor or any JV Subsidiary Guarantor addressed to the Holder, to provide information concerning such Holder's or its beneficial owner's nationality, residence, identity or connection with any Relevant Jurisdiction or the jurisdiction through which payments are made, if and to the extent that due and timely compliance with such request is required under the tax laws of such jurisdiction in order to reduce or eliminate any withholding or deduction as to which Additional Amounts would have otherwise been payable to such Holder; or
  - (iv) the presentation of such Note (in cases in which presentation is required) for payment in the Relevant Jurisdiction or the jurisdiction through which payments are made, unless such Note could not have been presented for payment elsewhere;
- (b) any estate, inheritance, gift, sale, transfer, personal property or similar tax, assessment or governmental charge;
  - (c) any withholding or deduction that is imposed or levied on a payment to an individual and is required to be made pursuant to European Council Directive 2003/48/EC or any other Directive implementing the conclusions of the ECOFIN Council meeting of November 26–27, 2000 on the taxation of savings income or any law implementing or complying with, or introduced in order to conform to, such Directives;
  - (d) any tax, assessment, withholding or deduction required by sections 1471 through 1474 of the Internal Revenue Code of 1986, as amended (“FATCA”), any current or future Treasury Regulations or rulings promulgated thereunder, any law, regulation or other official guidance enacted in any jurisdiction implementing FATCA, any intergovernmental agreement between the United States and any other jurisdiction pursuant to the implementation of FATCA, or any other agreement pursuant to the implementation of FATCA; or
  - (e) any combination of taxes, duties, assessments or other governmental charges referred to in the preceding clauses (a), (b), (c) and (d); or
- (2) to a Holder that is a fiduciary, partnership or person other than the sole beneficial owner of any payment to the extent that such payment would be required to be included in the income under the laws of a Relevant Jurisdiction or the jurisdiction through which payments are made, for tax purposes, of a beneficiary or settlor with respect to the fiduciary, or a member of that partnership or a beneficial owner who would not have been entitled to such Additional Amounts had that beneficiary, settlor, partner or beneficial owner been the Holder thereof.

Whenever there is mentioned in any context the payment of principal of, and any premium or interest on, any Note or under any Subsidiary Guarantee or JV Subsidiary Guarantee, such mention shall be deemed to include payment of Additional Amounts provided for in the Indenture to the extent that, in such context, Additional Amounts are, were or would be payable in respect thereof.

### **Redemption for Taxation Reasons**

The Notes may be redeemed, at the option of the Company or a Surviving Person with respect to the Company, as a whole but not in part, upon giving not less than 30 days' nor more than 60 days' notice to the Holders (which notice shall be irrevocable), at a redemption price equal to 100% of the principal amount thereof, together with accrued and unpaid interest (including any Additional Amounts), if any, to the date fixed by the Company or the Surviving Person, as the case may be, for redemption (the "Tax Redemption Date") if, as a result of:

- (1) any change in, or amendment to, the laws (or any regulations or rulings promulgated thereunder) of a Relevant Jurisdiction affecting taxation; or
- (2) any change in the existing official position or the stating of an official position regarding the application or interpretation of such laws, regulations or rulings (including a holding, judgment or order by a court of competent jurisdiction),

which change or amendment is proposed and becomes effective (i) with respect to the Company or any initial Subsidiary Guarantor, on or after the Original Issue Date, or (ii) with respect to any Future Subsidiary Guarantor, JV Subsidiary Guarantor or Surviving Person, on or after the date such Future Subsidiary Guarantor, JV Subsidiary Guarantor or Surviving Person becomes a Subsidiary Guarantor, JV Subsidiary Guarantor or Surviving Person, with respect to any payment due or to become due under the Notes or the Indenture, the Company, a Surviving Person or a Subsidiary Guarantor or JV Subsidiary Guarantor, as the case may be, is, or on the next Interest Payment Date would be, required to pay Additional Amounts, and such requirement cannot be avoided by the taking of reasonable measures by the Company, a Surviving Person, a Subsidiary Guarantor or JV Subsidiary Guarantor, as the case may be; *provided* that no such notice of redemption shall be given earlier than 90 days prior to the earliest date on which the Company, a Surviving Person, a Subsidiary Guarantor or a JV Subsidiary Guarantor, as the case may be, would be obligated to pay such Additional Amounts if a payment in respect of the Notes were then due.

Prior to the giving of any notice of redemption of the Notes pursuant to the foregoing, the Company, a Surviving Person, a Subsidiary Guarantor or a JV Subsidiary Guarantor, as the case may be, will deliver to the Trustee at least 30 days but not more than 60 days before a redemption date:

- (1) an Officers' Certificate stating that such change or amendment referred to in the prior paragraph has occurred, describing the facts related thereto and stating that such requirement cannot be avoided by the Company, such Surviving Person, Subsidiary Guarantor or JV Subsidiary Guarantor, as the case may be, taking reasonable measures available to it; and
- (2) an Opinion of Counsel or an opinion of a tax consultant, in either case of recognized standing with respect to tax matters of the Relevant Jurisdiction, stating that the requirement to pay such Additional Amounts results from such change or amendment referred to in the prior paragraph.

The Trustee shall accept such certificate and opinion as sufficient evidence of the satisfaction of the conditions precedent described above, in which event it shall be conclusive and binding on the Holders.

Any Notes that are redeemed will be cancelled.

### **Certain Covenants**

Set forth below are summaries of certain covenants contained in the Indenture.

#### ***Limitation on Indebtedness and Preferred Stock***

- (1) The Company will not, and will not permit any Restricted Subsidiary to, Incur any Indebtedness (including Acquired Indebtedness), and the Company will not permit any

Restricted Subsidiary to issue Preferred Stock, *provided* that the Company may Incur Indebtedness (including Acquired Indebtedness) and any Restricted Subsidiary may Incur Permitted Subsidiary Indebtedness if, after giving effect to the Incurrence of such Indebtedness and the receipt and application of the proceeds therefrom, (x) no Default has occurred and is continuing and (y) the Fixed Charge Coverage Ratio would be not less than 3.0 to 1.0. Notwithstanding the foregoing, the Company will not permit any Restricted Subsidiary to Incur any Disqualified Stock (other than Disqualified Stock held by the Company or a Subsidiary Guarantor, so long as it is so held).

- (2) Notwithstanding the foregoing, the Company and, to the extent provided below, any Restricted Subsidiary may Incur each and all of the following (“Permitted Indebtedness”):
- (a) Indebtedness under the Notes (excluding any Additional Notes and any Permitted Pari Passu Secured Indebtedness of the Company) and each Subsidiary Guarantee and JV Subsidiary Guarantee;
  - (b) any Pari Passu Subsidiary Guarantees by any Subsidiary Guarantor or any JV Subsidiary Guarantor;
  - (c) Indebtedness of the Company or any Restricted Subsidiary outstanding on the Original Issue Date excluding Indebtedness permitted under clause (d); *provided* that such Indebtedness of Restricted Subsidiaries shall be included in the calculation of Permitted Subsidiary Indebtedness;
  - (d) Indebtedness of the Company or any Restricted Subsidiary owed to the Company or any Restricted Subsidiary; *provided* that (i) any event which results in any such Restricted Subsidiary ceasing to be a Restricted Subsidiary or any subsequent transfer of such Indebtedness (other than to the Company or any Restricted Subsidiary) shall be deemed, in each case, to constitute an Incurrence of such Indebtedness not permitted by this clause (d) and (ii) if the Company is the obligor on such Indebtedness, such Indebtedness must expressly be subordinated in right of payment to the Notes, and if a Subsidiary Guarantor or a JV Subsidiary Guarantor is the obligor on such Indebtedness and the Company is not the obligee, such Indebtedness must be expressly subordinated in right of payment to the Subsidiary Guarantee of such Subsidiary Guarantor or the JV Subsidiary Guarantee of such JV Subsidiary Guarantor, as the case may be;
  - (e) Indebtedness (“Permitted Refinancing Indebtedness”) issued in exchange for, or the net proceeds of which are used to refinance or refund, replace, exchange, renew, repay, defease, discharge or extend (collectively, “refinance” and “refinances” and “refinanced” shall have a correlative meaning), then outstanding Indebtedness Incurred under the immediately preceding paragraph (1) or clauses (a), (b), (c), (h), (p) or (r) of this paragraph (2) and any refinancings thereof in an amount not to exceed the amount so refinanced or refunded (plus premiums, accrued interest, fees and expenses); *provided* that (i) Indebtedness the proceeds of which are used to refinance or refund the Notes or Indebtedness that is *pari passu* with, or subordinated in right of payment to, the Notes or a Subsidiary Guarantee or a JV Subsidiary Guarantee shall only be permitted under this clause (e) if (A) in case the Notes are refinanced in part or the Indebtedness to be refinanced is *pari passu* with the Notes or a Subsidiary Guarantee or a JV Subsidiary Guarantee, such new Indebtedness, by its terms or by the terms of any agreement or instrument pursuant to which such new Indebtedness is outstanding, is expressly made *pari passu* with, or subordinate in right of payment to, the remaining Notes or such Subsidiary Guarantee or such JV Subsidiary Guarantee, as the case may be, or (B) in case the Indebtedness to be refinanced is subordinated in right of payment to the Notes or a Subsidiary Guarantee or a JV Subsidiary Guarantee, such new Indebtedness, by its terms or by the terms of any agreement or instrument pursuant to which such new Indebtedness is issued or remains outstanding, is expressly made subordinate in right of payment to the Notes or such Subsidiary Guarantee or such JV Subsidiary Guarantee, as the case may be, at least to the extent that the Indebtedness to be refinanced is subordinated to the Notes or

such Subsidiary Guarantee or such JV Subsidiary Guarantee, (ii) such new Indebtedness, determined as of the date of Incurrence of such new Indebtedness, does not mature prior to the Stated Maturity of the Indebtedness to be refinanced or refunded, and the Average Life of such new Indebtedness is at least equal to the remaining Average Life of the Indebtedness to be refinanced or refunded, (iii) in no event may Indebtedness of the Company, any Subsidiary Guarantor or any JV Subsidiary Guarantor be refinanced pursuant to this clause by means of any Indebtedness of any Restricted Subsidiary that is not a Subsidiary Guarantor or a JV Subsidiary Guarantor, and (iv) in no event may Indebtedness of the Company or any Subsidiary Guarantor be refinanced pursuant to this clause by means of any Indebtedness of any JV Subsidiary Guarantor;

- (f) Indebtedness Incurred by the Company or any Restricted Subsidiary pursuant to Hedging Obligations entered into in the ordinary course of business and designed solely to protect the Company or any of its Restricted Subsidiaries from fluctuations in interest rates, currencies or the price of commodities and not for speculation;
- (g) Pre-Registration Mortgage Guarantees by the Company or any Restricted Subsidiary;
- (h) Indebtedness Incurred by the Company or any Restricted Subsidiary for the purpose of financing (x) all or any part of the purchase price of assets, real or personal property (including the lease purchase price of land use rights) or equipment to be used in the ordinary course of business by the Company or a Restricted Subsidiary in the Permitted Business, including any such purchase through the acquisition of Capital Stock of any Person that owns such real or personal property or equipment which will, upon acquisition, become a Restricted Subsidiary, or (y) all or any part of the purchase price or the cost of development, construction or improvement of real or personal property (including the lease purchase price of land use rights) or equipment to be used in the ordinary course of business by the Company or such Restricted Subsidiary in the Permitted Business; *provided* that in the case of clauses (x) and (y), (A) the aggregate principal amount of such Indebtedness shall not exceed such purchase price or cost, (B) such Indebtedness shall be Incurred no later than 180 days after the acquisition of such property or completion of such development, construction or improvement and (C) on the date of the Incurrence of such Indebtedness and after giving effect thereto, the sum of (1) the aggregate principal amount outstanding of all such Indebtedness permitted by this clause (h) (together with refinancings thereof, but excluding any Contractor Guarantee Incurred under this clause (h) and Guarantee Incurred under clauses (p) and (r) below to the extent the amount of such Contractor Guarantee or Guarantees is otherwise reflected in such aggregate principal amount) plus (2) the aggregate amount of all Indebtedness permitted and then outstanding under clauses (p) and (r) below does not exceed an amount equal to 20.0% of Total Assets;
- (i) Indebtedness Incurred by the Company or any Restricted Subsidiary constituting reimbursement obligations with respect to workers' compensation claims or self-insurance obligations or bid, performance or surety bonds (in each case other than for an obligation for borrowed money);
- (j) Indebtedness Incurred by the Company or any Restricted Subsidiary constituting reimbursement obligations with respect to letters of credit or trade guarantees issued in the ordinary course of business to the extent that such letters of credit or trade guarantees are not drawn upon or, if drawn upon, to the extent such drawing is reimbursed no later than the 30 days following receipt by the Company or such Restricted Subsidiary of a demand for reimbursement;
- (k) Indebtedness arising from agreements providing for indemnification, adjustment of purchase price or similar obligations, or from Guarantees or letters of credit, surety bonds or performance bonds securing any obligation of the Company or any Restricted Subsidiary pursuant to such agreements, in any case, Incurred in connection with the disposition of any business, assets or Restricted Subsidiary, other than Guarantees of

Indebtedness Incurred by any Person acquiring all or any portion of such business, assets or Restricted Subsidiary for the purpose of financing such acquisition; *provided* that the maximum aggregate liability in respect of all such Indebtedness in the nature of such Guarantee shall at no time exceed the gross proceeds actually received from the sale of such business, assets or Restricted Subsidiary;

- (l) Indebtedness arising from the honoring by a bank or other financial institution of a check, draft or similar instrument drawn against insufficient funds in the ordinary course of business *provided, however*, that such Indebtedness is extinguished within five Business Days of Incurrence;
  - (m) (i) Guarantees by the Company or any Subsidiary Guarantor of Indebtedness of the Company or any Restricted Subsidiary that was permitted to be Incurred by another provision of this covenant or, (ii) Guarantees by any Restricted Subsidiary of Indebtedness of another Restricted Subsidiary that was permitted to be Incurred under clause (f) or (h) above or clause (n) below or (iii) Guarantees by any JV Subsidiary Guarantor of Indebtedness of any other JV Subsidiary Guarantor that is a direct or indirect Subsidiary or parent of such JV Subsidiary Guarantor, which Indebtedness was permitted to be Incurred by another provision of this covenant;
  - (n) Indebtedness of the Company or any Restricted Subsidiary with a maturity of one year or less used by the Company or any Restricted Subsidiary for working capital; *provided* that the aggregate principal amount of Indebtedness permitted by this clause (n) at any time outstanding does not exceed US\$20.0 million (or the Dollar Equivalent thereof);
  - (o) Indebtedness of the Company or any Restricted Subsidiary constituting an obligation to pay the deferred purchase price of Capital Stock in a Restricted Subsidiary pursuant to a Staged Acquisition Agreement, to the extent that such deferred purchase price is paid within 12 months after the date the Company or such Restricted Subsidiary enters into such Staged Acquisition Agreement;
  - (p) Preferred Stock or Disqualified Stock issued by a PRC Subsidiary in connection with, and Indebtedness of the Company or a PRC Restricted Subsidiary constituting a Guarantee by, or grant of a Lien on the assets of, the Company or a PRC Subsidiary in favor of an Insurance Company Investor with respect to the obligation to pay a guaranteed or preferred return to such Insurance Company Investor on Capital Stock of such PRC Restricted Subsidiary held by such Insurance Company Investor, *provided* that on the date of such Incurrence of all such Indebtedness and after giving effect thereto, the sum of (1) the aggregate amount of all Indebtedness permitted and then outstanding under this clause (p) plus (2) the aggregate principal amount outstanding of all Indebtedness permitted under clause (h) (together with refinancing thereof, but excluding any Contractor Guarantee Incurred under such clause (h) and Guarantees Incurred under this clause and clause (r) below to the extent the amount of such Contractor Guarantee or Guarantee is otherwise reflected in such aggregate principal amount), does not exceed an amount equal to 20.0% of Total Assets;
  - (q) Indebtedness of the Company or any Restricted Subsidiary in an aggregate principal amount outstanding at any time (together with refinancings thereof) not to exceed US\$10.0 million (or the Dollar Equivalent thereof); and
  - (r) Bank Deposit Secured Indebtedness Incurred by the Company or any of its Restricted Subsidiaries, *provided* that on the date of Incurrence of such Indebtedness and after giving effect thereto, the sum of, (1) the aggregate principal amount outstanding of such Indebtedness Incurred under this clause (r), *plus* (2) the aggregate principal amount outstanding of all Indebtedness Incurred under clauses (h) and (p) above (together with refinancing thereof, but excluding any Contractor Guarantee or Guarantees under such clauses) does not exceed an amount equal to 20.0% of Total Assets.
- (3) For purposes of determining compliance with this “Limitation on Indebtedness and Preferred Stock” covenant, in the event that an item of Indebtedness meets the criteria of more than one

of the types of Indebtedness described above, including under the proviso in the first paragraph, the Company, in its sole discretion, shall classify, and from time to time may reclassify, such item of Indebtedness.

- (4) Notwithstanding any other provision of this covenant, the maximum amount of Indebtedness that may be Incurred pursuant to this covenant will not be deemed to be exceeded with respect to any outstanding Indebtedness due solely to the result of fluctuations in the exchange rates of currencies.

#### ***Limitation on Restricted Payments***

The Company will not, and will not permit any Restricted Subsidiary to, directly or indirectly (the payments or any other actions described in clauses (1) through (4) below being collectively referred to as “Restricted Payments”):

- (1) declare or pay any dividend or make any distribution on or with respect to the Company’s or any of its Restricted Subsidiaries’ Capital Stock (other than dividends or distributions payable or paid in shares of the Company’s or any of its Restricted Subsidiaries’ Capital Stock (other than Disqualified Stock or Preferred Stock) or in options, warrants or other rights to acquire shares of such Capital Stock) held by Persons other than the Company or any Wholly Owned Restricted Subsidiary;
- (2) purchase, call for redemption or redeem, retire or otherwise acquire for value any shares of Capital Stock of the Company or any Restricted Subsidiary (including options, warrants or other rights to acquire such shares of Capital Stock) or any direct or indirect parent of the Company held by any Persons other than the Company or any Wholly Owned Restricted Subsidiary other than (i) the purchase of Capital Stock of a Restricted Subsidiary pursuant to a Staged Acquisition Agreement or (ii) the purchase of Capital Stock of a Restricted Subsidiary held by any Insurance Company Investor;
- (3) make any voluntary or optional principal payment, or voluntary or optional redemption, repurchase, defeasance, or other acquisition or retirement for value, of Indebtedness that is subordinated in right of payment to the Notes or any of the Subsidiary Guarantees or any of the JV Subsidiary Guarantees (excluding any intercompany Indebtedness between or among the Company and any of its Wholly Owned Restricted Subsidiaries); or
- (4) make any Investment, other than a Permitted Investment;

if, at the time of, and after giving effect to, the proposed Restricted Payment:

- (a) a Default has occurred and is continuing or would occur as a result of such Restricted Payment;
- (b) the Company could not Incur at least US\$1.00 of Indebtedness under the proviso in the first paragraph of the covenant under the caption “— Limitation on Indebtedness and Preferred Stock;” or
- (c) such Restricted Payment, together with the aggregate amount of all Restricted Payments made by the Company and its Restricted Subsidiaries after the Measurement Date, shall exceed the sum of:
  - (i) 50% of the aggregate amount of the Consolidated Net Income of the Company (or, if the Consolidated Net Income is a loss, minus 100% of the amount of such loss) accrued on a cumulative basis during the period (taken as one accounting period) beginning on the first day of the fiscal quarter during which the 2010 Notes were first issued and ending on the last day of the Company’s most recently ended fiscal quarter for which consolidated financial statements of the Company (which the Company shall use its best efforts to compile in a timely manner) are available (which may include internal consolidated financial statements); plus

- (ii) 100% of the aggregate Net Cash Proceeds received by the Company after the Measurement Date as a capital contribution to its common equity or from the issuance and sale of its Capital Stock (other than Disqualified Stock) to a Person who is not a Subsidiary of the Company, including any such Net Cash Proceeds received upon (A) the conversion of any Indebtedness (other than Subordinated Indebtedness) of the Company into Capital Stock (other than Disqualified Stock) of the Company, or (B) the exercise by a Person who is not a Subsidiary of the Company of any options, warrants or other rights to acquire Capital Stock of the Company (other than Disqualified Stock) in each case excluding the amount of any such Net Cash Proceeds used to redeem, repurchase, defease or otherwise acquire or retire for value any Subordinated Indebtedness or Capital Stock of the Company; plus
- (iii) the amount by which Indebtedness of the Company or any of its Restricted Subsidiaries is reduced on the Company's consolidated balance sheet upon the conversion or exchange (other than by a Subsidiary of the Company) subsequent to the Measurement Date of any Indebtedness of the Company or any of its Restricted Subsidiaries convertible or exchangeable into Capital Stock (other than Disqualified Stock) of the Company (less the amount of any cash, or the Fair Market Value of any other property, distributed by the Company upon such conversion or exchange); plus
- (iv) an amount equal to the net reduction in Investments (other than reductions in Permitted Investments) that were made after the Measurement Date in any Person resulting from (A) payments of interest on Indebtedness, dividends or repayments of loans or advances by such Person, in each case to the Company or any Restricted Subsidiary (except, in each case, to the extent any such payment or proceeds are included in the calculation of Consolidated Net Income) after the Measurement Date, (B) the unconditional release of a Guarantee provided by the Company or a Restricted Subsidiary after the Measurement Date of an obligation of another Person, (C) to the extent that an Investment made after the Measurement Date was, after such date, or is sold or otherwise liquidated or repaid for cash, the lesser of (x) cash return of capital with respect to such Investment (less the cost of disposition, if any) and (y) the initial amount of such Investment, or (D) from redesignations of Unrestricted Subsidiaries as Restricted Subsidiaries, not to exceed, in each case, the amount of Investments (other than Permitted Investments) made by the Company or a Restricted Subsidiary after the Measurement Date in any such Person; plus
- (v) US\$5.0 million (or the Dollar Equivalent thereof).

The foregoing provision shall not be violated by reason of:

- (1) the payment of any dividend or redemption of any Capital Stock within 60 days after the related date of declaration or call for redemption if, at said date of declaration or call for redemption, such payment or redemption would comply with the preceding paragraph;
- (2) the redemption, repurchase, defeasance or other acquisition or retirement for value of Subordinated Indebtedness of the Company or any of the Subsidiary Guarantors or JV Subsidiary Guarantors with the Net Cash Proceeds of, or in exchange for, a substantially concurrent Incurrence of Permitted Refinancing Indebtedness;
- (3) the redemption, repurchase or other acquisition of Capital Stock of the Company or any Subsidiary Guarantor or JV Subsidiary Guarantor (or options, warrants or other rights to acquire such Capital Stock) in exchange for, or out of the Net Cash Proceeds of a substantially concurrent capital contribution or a sale (other than to a Subsidiary of the Company) of, shares of the Capital Stock (other than Disqualified Stock) of the Company or any Subsidiary Guarantor (or options, warrants or other rights to acquire such Capital Stock); *provided* that the amount of any such Net Cash Proceeds that are utilized for any such Restricted Payment will be

excluded from clause (c)(ii) of the preceding paragraph, *provided however* that any item that has been excluded pursuant to clause (c)(ii) of the preceding paragraph will not be excluded again as a result of the proviso in this clause (3);

- (4) the redemption, repurchase, defeasance or other acquisition or retirement for value of Subordinated Indebtedness of the Company or any of the Subsidiary Guarantors or JV Subsidiary Guarantors in exchange for, or out of the Net Cash Proceeds of, a substantially concurrent capital contribution or sale (other than to a Subsidiary of the Company) of, shares of Capital Stock (other than Disqualified Stock) of the Company or any of the Subsidiary Guarantors or JV Subsidiary Guarantors (or options, warrants or other rights to acquire such Capital Stock); *provided* that the amount of any such Net Cash Proceeds that are utilized for any such Restricted Payment will be excluded from clause (c)(ii) of the preceding paragraph, *provided however* that any item that has been excluded pursuant to clause (c)(ii) of the preceding paragraph will not be excluded again as a result of the proviso in this clause (4); or
- (5) the payment of any dividends or distributions declared, paid or made by a Restricted Subsidiary payable, on a pro rata basis or on a basis more favorable to the Company, to all holders of any class of Capital Stock of such Restricted Subsidiary, a majority of which is held, directly or indirectly through Restricted Subsidiaries, by the Company;

*provided* that, in the case of clause (2), (3) or (4) of the preceding paragraph, no Default shall have occurred and be continuing or would occur as a consequence of the actions or payments set forth therein.

Each Restricted Payment permitted pursuant to clause (1) of the preceding paragraph shall be included in calculating whether the conditions of clause (c) of the first paragraph of this “— Limitation on Restricted Payments” covenant have been met with respect to any subsequent Restricted Payments.

The amount of any Restricted Payments (other than cash) will be the Fair Market Value on the date of the Restricted Payment of the asset(s) or securities proposed to be transferred or issued by the Company or the Restricted Subsidiary, as the case may be, pursuant to the Restricted Payment. The value of any assets or securities that are required to be valued by this covenant will be the Fair Market Value. The Board of Directors’ determination of the Fair Market Value of a Restricted Payment or any such assets or securities must be based upon an opinion or appraisal issued by an appraisal or investment banking firm of recognized international standing if the Fair Market Value exceeds US\$10.0 million (or the Dollar Equivalent thereof).

Not later than the date of making any Restricted Payment in excess of US\$10.0 million (or the Dollar Equivalent thereof), the Company will deliver to the Trustee an Officers’ Certificate stating that such Restricted Payment is permitted and setting forth the basis upon which the calculations required by this “— Limitation on Restricted Payments” covenant were computed, together with a copy of any fairness opinion or appraisal required by the Indenture.

***Limitation on Dividend and Other Payment Restrictions Affecting Restricted Subsidiaries***

- (1) Except as provided below, the Company will not, and will not permit any Restricted Subsidiary to, create or otherwise cause or permit to exist or become effective any encumbrance or restriction on the ability of any Restricted Subsidiary to:
  - (a) pay dividends or make any other distribution on any Capital Stock of such Restricted Subsidiary owned by the Company or any other Restricted Subsidiary;
  - (b) pay any Indebtedness or other obligation owed to the Company or any other Restricted Subsidiary;
  - (c) make loans or advances to the Company or any other Restricted Subsidiary; or
  - (d) sell, lease or transfer any of its property or assets to the Company or any other Restricted Subsidiary.



- (2) The provisions of paragraph (1) do not apply to any encumbrances or restrictions:
- (a) existing in agreements as in effect on the Original Issue Date, or in the Notes, the Subsidiary Guarantees, the JV Subsidiary Guarantees, the Indenture, the Security Documents, or under any Permitted Pari Passu Secured Indebtedness of the Company or any Subsidiary Guarantor Pledgor or Pari Passu Subsidiary Guarantee of any Subsidiary Guarantor or any JV Subsidiary Guarantor, and any extensions, refinancings, renewals or replacements of any of the foregoing agreements; *provided* that the encumbrances and restrictions in any such extension, refinancing, renewal or replacement, taken as a whole, are no more restrictive in any material respect to the Holders than those encumbrances or restrictions that are then in effect and that are being extended, refinanced, renewed or replaced;
  - (b) existing under or by reason of applicable law, rule, regulation or order;
  - (c) existing with respect to any Person or the property or assets of such Person acquired by the Company or any Restricted Subsidiary, at the time of such acquisition and not incurred in contemplation thereof, which encumbrances or restrictions are not applicable to any Person or the property or assets of any Person other than such Person or the property or assets of such Person so acquired, and any extensions, refinancings, renewals or replacements thereof; *provided* that the encumbrances and restrictions in any such extension, refinancing, renewal or replacement, taken as a whole, are no more restrictive in any material respect to the Holders than those encumbrances or restrictions that are then in effect and that are being extended, refinanced, renewed or replaced;
  - (d) that otherwise would be prohibited by the provision described in clause (1)(d) of this covenant if they arise, or are agreed to, in the ordinary course of business and, that (i) restrict in a customary manner the subletting, assignment or transfer of any property or asset that is subject to a lease or license, or (ii) exist by virtue of any Lien on, or agreement to transfer, option or similar right with respect to any property or assets of the Company or any Restricted Subsidiary not otherwise prohibited by the Indenture or (iii) do not relate to any Indebtedness, and that do not, individually or in the aggregate, detract from the value of property or assets of the Company or any Restricted Subsidiary in any manner material to the Company or any Restricted Subsidiary;
  - (e) with respect to a Restricted Subsidiary and imposed pursuant to an agreement that has been entered into for the sale or disposition of all or substantially all of the Capital Stock of, or property and assets of, such Restricted Subsidiary that is permitted by the “— Limitation on Sales and Issuances of Capital Stock in Restricted Subsidiaries,” “— Limitation on Indebtedness and Preferred Stock” and “— Limitation on Asset Sales” covenants;
  - (f) with respect to any Restricted Subsidiary and imposed pursuant to an agreement that has been entered into for the Incurrence of Indebtedness of the type described under clause (2)(h) or permitted under clause (2)(n) or 2(r) of the “— Limitation on Indebtedness and Preferred Stock” covenant if, as determined by the Board of Directors, the encumbrances or restrictions are (i) customary for such types of agreements and (ii) would not, at the time agreed to, be expected to materially and adversely affect the ability of the Company to make required payment on the Notes and, with respect to Indebtedness of the type described in clause 2(h) or permitted under clause 2(r), any extensions, refinancings, renewals or replacements of any of the foregoing agreements; *provided* that the encumbrances and restrictions in any such extension, refinancing, renewal or replacement, taken as a whole, are no more restrictive in any material respect to the Holders than those encumbrances or restrictions that are then in effect and that are being extended, refinanced, renewed or replaced;

- (g) existing in customary provisions in joint venture agreements and other similar agreements permitted under the Indenture, to the extent such encumbrance or restriction relates to the activities or assets of a Restricted Subsidiary that is a party to such joint venture and if (as determined in good faith by the Board of Directors) (i) the encumbrances or restrictions are customary for a joint venture or similar agreement of that type and (ii) the encumbrances or restrictions would not, at the time agreed to, be expected to materially and adversely affect (x) the ability of the Company to make the required payments on the Notes, or (y) any Subsidiary Guarantor to make required payments under its Subsidiary Guarantee; or
- (h) existing with respect to any Unrestricted Subsidiary or the property or assets of such Unrestricted Subsidiary that is designated as a Restricted Subsidiary in accordance with the terms of the Indenture at the time of such designation and not incurred in contemplation of such designation, which encumbrances or restrictions are not applicable to any Person or the property or assets of any Person other than such Subsidiary or its subsidiaries or the property or assets of such Subsidiary or its subsidiaries, and any extensions, refinancing, renewals or replacements thereof; provided that the encumbrances and restrictions in any such extension, refinancing, renewal or replacement, taken as a whole, are no more restrictive in any material respect to the Holders than those encumbrances or restrictions that are then in effect and that are being extended, refinanced, renewed or replaced.

#### ***Limitation on Sales and Issuances of Capital Stock in Restricted Subsidiaries***

The Company will not sell, and will not permit any Restricted Subsidiary, directly or indirectly, to issue or sell any shares of Capital Stock of a Restricted Subsidiary (including options, warrants or other rights to purchase shares of such Capital Stock) except:

- (1) to the Company or a Wholly Owned Restricted Subsidiary, or in the case of a Restricted Subsidiary that is not Wholly Owned, pro rata to its shareholders or incorporators;
- (2) to the extent such Capital Stock represents director's qualifying shares or is required by applicable law to be held by a Person other than the Company or a Wholly Owned Restricted Subsidiary;
- (3) for the sale of all of the shares of the Capital Stock of a Restricted Subsidiary if permitted under, and made in accordance with, the "— Limitation on Asset Sales" covenant;
- (4) the issuance or sale of Capital Stock of a Restricted Subsidiary if, immediately after giving effect to such issuance or sale, such Restricted Subsidiary would no longer constitute a Restricted Subsidiary, *provided* that any remaining Investment in such Person would have been permitted to be made under the "— Limitation on Restricted Payments" covenant if made on the date of such issuance or sale and *provided* that the Company complies with the "— Limitation on Asset Sales" covenant; or
- (5) the issuance or sale of Capital Stock of a Restricted Subsidiary (which remains a Restricted Subsidiary after any such issuance or sale); *provided* that the Company or such Restricted Subsidiary applies the Net Cash Proceeds of such issuance or sale in accordance with the "— Limitation on Asset Sales" covenant.

#### ***Limitation on Issuances of Guarantees by Restricted Subsidiaries***

The Company will not permit any Restricted Subsidiary which is not a Subsidiary Guarantor or a JV Subsidiary Guarantor, directly or indirectly, to Guarantee any Indebtedness ("Guaranteed Indebtedness") of the Company or any other Restricted Subsidiary, unless (1)(a) such Restricted Subsidiary simultaneously executes and delivers a supplemental indenture to the Indenture providing for an unsubordinated Subsidiary Guarantee (in the case of a Subsidiary Guarantor) or JV Subsidiary Guarantee

(in the case of a JV Subsidiary Guarantor) of payment of the Notes by such Restricted Subsidiary and (b) such Restricted Subsidiary waives and will not in any manner whatsoever claim or take the benefit or advantage of, any rights of reimbursement, indemnity or subrogation or any other rights against the Company or any other Restricted Subsidiary as a result of any payment by such Restricted Subsidiary under its Subsidiary Guarantee or JV Subsidiary Guarantee, as the case may be, until the Notes have been paid in full or (2) such Guarantee and such Guaranteed Indebtedness are permitted by clauses (2)(c), (d), (m)(ii) (other than a Guarantee by a PRC Restricted Subsidiary of the Indebtedness of a non-PRC Restricted Subsidiary that is not a Subsidiary of such PRC Subsidiary) or (r) (in the case of clause (2)(r), with respect to the Guarantee provided by the Company or any Restricted Subsidiary through the pledge of one or more bank accounts to secure, directly or indirectly, any Bank Deposit Secured Indebtedness), under the caption “— Limitation on Indebtedness and Preferred Stock.”

If the Guaranteed Indebtedness (1) ranks *pari passu* in right of payment with the Notes, any Subsidiary Guarantee or any JV Subsidiary Guarantee, then the Guarantee of such Guaranteed Indebtedness shall rank *pari passu* in right of payment with, or subordinated to, the Subsidiary Guarantee or the JV Subsidiary Guarantee, as the case may be, or (2) is subordinated in right of payment to the Notes, any Subsidiary Guarantee or any JV Subsidiary Guarantee, then the Guarantee of such Guaranteed Indebtedness shall be subordinated in right of payment to the Subsidiary Guarantee or the JV Subsidiary Guarantee, as the case may be, at least to the extent that the Guaranteed Indebtedness is subordinated to the Notes, the Subsidiary Guarantee or the JV Subsidiary Guarantee.

The Company will not permit any JV Subsidiary Guarantor, directly or indirectly, to guarantee any Indebtedness of the Company or any other Restricted Subsidiary unless the aggregate claims of the creditor under such guarantee will be limited to the JV Entitlement Amount. If any JV Subsidiary Guarantor guarantees any Indebtedness of the Company or any other Restricted Subsidiary where the aggregate claims of the creditor under such guarantee exceeds the JV Entitlement Amount, such JV Subsidiary Guarantee shall be replaced with a Subsidiary Guarantee given by a Subsidiary Guarantor.

#### ***Limitation on Transactions with Shareholders and Affiliates***

The Company will not, and will not permit any Restricted Subsidiary to, directly or indirectly, enter into, renew or extend any transaction or arrangement (including, without limitation, the purchase, sale, lease or exchange of property or assets, or the rendering of any service) with (x) any holder (or any Affiliate of such holder) of 10.0% or more of any class of Capital Stock of the Company or (y) any Affiliate of the Company (each an “Affiliate Transaction”), unless:

- (1) the Affiliate Transaction is on fair and reasonable terms that are no less favorable to the Company or the relevant Restricted Subsidiary than those that would have been obtained in a comparable transaction by the Company or the relevant Restricted Subsidiary with a Person that is not an Affiliate of the Company; and
- (2) the Company delivers to the Trustee:
  - (a) with respect to any Affiliate Transaction or series of related Affiliate Transactions involving aggregate consideration in excess of US\$3.0 million (or the Dollar Equivalent thereof), a Board Resolution set forth in an Officers’ Certificate certifying that such Affiliate Transaction complies with this covenant and such Affiliate Transaction has been approved by a majority of the disinterested members of the Board of Directors; and
  - (b) with respect to any Affiliate Transaction or series of related Affiliate Transactions involving aggregate consideration in excess of US\$10.0 million (or the Dollar Equivalent thereof), in addition to the Board Resolution required in clause 2(a) above, an opinion as to the fairness to the Company or the relevant Restricted Subsidiary of such Affiliate Transaction from a financial point of view issued by an accounting, appraisal or investment banking firm of recognized international standing.

The foregoing limitation does not limit, and shall not apply to:

- (1) the payment of reasonable and customary regular fees to directors of the Company who are not employees of the Company;

- (2) transactions between or among the Company and any of its Wholly Owned Restricted Subsidiaries or between or among Wholly Owned Restricted Subsidiaries;
- (3) any Restricted Payment of the type described in clauses (1) or (2) of the first paragraph of the covenant described above under the caption “— Limitation on Restricted Payments” if permitted by that covenant;
- (4) any sale of Capital Stock (other than Disqualified Stock) of the Company;
- (5) the payment of compensation to officers and directors of the Company or any Restricted Subsidiary pursuant to an employee stock or share option scheme, so long as such scheme is in compliance with the listing rules of The Stock Exchange of Hong Kong Limited, which as of the Original Issue Date require a majority shareholder approval of any such scheme;
- (6) any transaction between (A) the Company or any Restricted Subsidiary and (B) any entity in the Colour Life Group entered into in connection with the proposed Colour Life IPO, including but not limited to transactions entered into for purposes of any reorganization in connection with the proposed Colour Life IPO and the entry into, and the performance thereof, of any underwriting agreement or other transaction documents in connection with the proposed Colour Life IPO; and
- (7) any transaction between (A) the Company or any Restricted Subsidiary and (B) any entity in the Colour Life Group entered into in the ordinary course of business, on fair and reasonable terms and disclosed in the offering document issued in connection with the proposed Colour Life IPO, or any amendment or modification or extension or replacement thereof, so long as such amendment, modification or replacement is not more disadvantageous to the Company and its Restricted Subsidiaries than the original transaction described in the offering document issued in connection with the proposed Colour Life IPO and in compliance with the rules of The Stock Exchange of Hong Kong Limited or any other recognized exchange on which the Company’s ordinary shares are then listed for trading.

In addition, the requirements of clause (2) of the first paragraph of this covenant shall not apply to (i) Investments (other than Permitted Investments) not prohibited by the “— Limitation on Restricted Payments” covenant, (ii) transactions pursuant to agreements in effect on the Original Issue Date and described in this offering memorandum, or any amendment or modification or replacement thereof, so long as such amendment, modification or replacement is not more disadvantageous to the Company and its Restricted Subsidiaries than the original agreement in effect on the Original Issue Date and (iii) any transaction between or among the Company and any Restricted Subsidiary that is not a Wholly Owned Restricted Subsidiary or between or among Restricted Subsidiaries that are not Wholly Owned Restricted Subsidiaries; *provided* that in the case of clause (iii) (a) such transaction is entered into in the ordinary course of business and (b) none of the minority shareholders or minority partners of or in such Restricted Subsidiary that is not a Wholly Owned Subsidiary Guarantor is a Person described in clauses (x) or (y) of the first paragraph of this covenant (other than by reason of such minority shareholder or minority partner being an officer or director of such Restricted Subsidiary).

#### ***Limitation on Liens***

The Company will not, and will not permit any of its Restricted Subsidiaries to, directly or indirectly, incur, assume or permit to exist any Lien on the Collateral (other than Permitted Liens).

The Company will not, and will not permit any of its Restricted Subsidiaries to, directly or indirectly, incur, assume or permit to exist any Lien of any nature whatsoever on any of its assets or properties of any kind (other than the Collateral), whether owned at the Original Issue Date or thereafter acquired, except Permitted Liens, unless the Notes are equally and ratably secured by such Lien.

### ***Limitation on Sale and Leaseback Transactions***

The Company will not, and will not permit any of its Restricted Subsidiaries to, enter into any Sale and Leaseback Transaction; *provided* that the Company may enter into a Sale and Leaseback Transaction if:

- (1) the Company could have (a) incurred Indebtedness in an amount equal to the Attributable Indebtedness relating to such Sale and Leaseback Transaction under the first paragraph of the covenant described above under “— Limitation on Indebtedness and Preferred Stock” and (b) incurred a Lien to secure such Indebtedness pursuant to the covenant described above under the caption “— Limitation on Liens,” in which case, the corresponding Indebtedness and Lien will be deemed incurred pursuant to those provisions;
- (2) the gross cash proceeds of that Sale and Leaseback Transaction are at least equal to the Fair Market Value of the property that is the subject of such Sale and Leaseback Transaction; and
- (3) the transfer of assets in that Sale and Leaseback Transaction is permitted by, and the Company applies the proceeds of such transaction in compliance with, the covenant described below under the caption “— Limitation on Asset Sales.”

### ***Limitation on Asset Sales***

The Company will not, and will not permit any Restricted Subsidiary to, consummate any Asset Sale, unless:

- (1) no Default shall have occurred and be continuing or would occur as a result of such Asset Sale;
- (2) the consideration received by the Company or such Restricted Subsidiary, as the case may be, is at least equal to the Fair Market Value of the assets sold or disposed of;
- (3) in the case of an Asset Sale that constitutes an Asset Disposition, the Company could Incur at least US\$1.00 of Indebtedness under the proviso in the first paragraph of the covenant under the caption “— Limitation on Indebtedness and Preferred Stock” after giving pro forma effect to such Asset Disposition; and
- (4) at least 75% of the consideration received consists of cash, Temporary Cash Investments or Replacement Assets; *provided* that in the case of an Asset Sale in which the Company or such Restricted Subsidiary receives Replacement Assets involving aggregate consideration in excess of US\$10.0 million (or the Dollar Equivalent thereof), the Company shall deliver to the Trustee an opinion as to the fairness to the Company or such Restricted Subsidiary of such Asset Sale from a financial point of view issued by an accounting, appraisal or investment banking firm of international standing. For purposes of this provision, each of the following will be deemed to be cash:
  - (a) any liabilities, as shown on the Company’s most recent consolidated balance sheet, of the Company or any Restricted Subsidiary (other than contingent liabilities and liabilities that are by their terms subordinated to the Notes, any Subsidiary Guarantee or any JV Subsidiary Guarantee) that are assumed by the transferee of any such assets pursuant to a customary assumption, assignment, novation or similar agreement that releases the Company or such Restricted Subsidiary from further liability; and
  - (b) any securities, notes or other obligations received by the Company or any Restricted Subsidiary from such transferee that are promptly, but in any event within 30 days of closing, converted by the Company or such Restricted Subsidiary into cash, to the extent of the cash received in that conversion;

Within 360 days after the receipt of any Net Cash Proceeds from an Asset Sale, the Company (or any Restricted Subsidiary) may apply such Net Cash Proceeds to:

- (1) permanently repay Senior Indebtedness of the Company or a Subsidiary Guarantor or any Indebtedness of a Restricted Subsidiary that is not a Subsidiary Guarantor (and, if such Senior Indebtedness repaid is revolving credit Indebtedness, to correspondingly reduce commitments with respect thereto) in each case owing to a Person other than the Company or a Restricted Subsidiary; or
- (2) acquire properties and assets that replace the properties and assets that were the subject of such Asset Sale or in properties or assets that will be used in the Permitted Businesses (“Replacement Assets”).

Any Net Cash Proceeds from Asset Sales that are not applied or invested as provided in clauses (1) and (2) in the immediately preceding paragraph will constitute “Excess Proceeds.” Excess Proceeds of less than US\$10.0 million (or the Dollar Equivalent thereof) will be carried forward and accumulated. When accumulated Excess Proceeds exceeds US\$10.0 million (or the Dollar Equivalent thereof), within 10 days thereof, the Company must make an Offer to Purchase Notes having a principal amount equal to:

- (1) accumulated Excess Proceeds, multiplied by
- (2) a fraction (x) the numerator of which is equal to the outstanding principal amount of the Notes and (y) the denominator of which is equal to the outstanding principal amount of the Notes and all *pari passu* Indebtedness similarly required to be repaid, redeemed or tendered for in connection with the Asset Sale, rounded down to the nearest US\$1,000.

The offer price in any Offer to Purchase will be equal to 100% of the principal amount plus accrued and unpaid interest to the date of purchase, and will be payable in cash.

If any Excess Proceeds remain after consummation of an Offer to Purchase, the Company may use those Excess Proceeds for any purpose not otherwise prohibited by the Indenture. If the aggregate principal amount of Notes (and any other *pari passu* Indebtedness) tendered in such Offer to Purchase exceeds the amount of Excess Proceeds, the Trustee will select the Notes (and such other *pari passu* Indebtedness) to be purchased on a pro rata basis. Upon completion of each Offer to Purchase, the amount of Excess Proceeds will be reset at zero.

#### ***Limitation on the Company’s Business Activities***

The Company will not, and will not permit any Restricted Subsidiary to, directly or indirectly, engage in any business other than Permitted Businesses; *provided, however*, that the Company or any Restricted Subsidiary may own Capital Stock of an Unrestricted Subsidiary or joint venture or other entity that is engaged in a business other than Permitted Businesses as long as any Investment therein was not prohibited when made by the covenant under the caption “— Limitation on Restricted Payments.”

#### ***Use of Proceeds***

The Company will not, and will not permit any Restricted Subsidiary to, use the net proceeds from the sale of the Notes, in any amount, for any purpose other than (1) in the approximate amounts and for the purposes specified, including any adjustment in response to changes in acquisition or development plans as contemplated, under the caption “Use of Proceeds” in this offering memorandum and (2) pending the application of all of such net proceeds in such manner, to invest the portion of such net proceeds not yet so applied in Temporary Cash Investments.

#### ***Designation of Restricted and Unrestricted Subsidiaries***

The Board of Directors may designate any Restricted Subsidiary to be an Unrestricted Subsidiary; *provided* that (1) no Default shall have occurred and be continuing at the time of or after giving effect to such designation; (2) neither the Company nor any Restricted Subsidiary provides credit support for the Indebtedness of such Restricted Subsidiary; (3) such Restricted Subsidiary has no outstanding Indebtedness that could trigger a cross-default to the Indebtedness of the Company; (4) such Restricted

Subsidiary does not own any Disqualified Stock of the Company or Disqualified or Preferred Stock of another Restricted Subsidiary or hold any Indebtedness of, or any Lien on any property of, the Company or any Restricted Subsidiary, if such Disqualified or Preferred Stock or Indebtedness could not be Incurred under the covenant described under the caption “— Limitation on Indebtedness and Preferred Stock” or such Lien would violate the covenant described under the caption “— Limitation on Liens;” (5) such Restricted Subsidiary does not own any Voting Stock of another Restricted Subsidiary, and all of its Subsidiaries are Unrestricted Subsidiaries or are being concurrently designated to be Unrestricted Subsidiaries in accordance with this paragraph; and (6) the Investment deemed to have been made thereby in such newly-designated Unrestricted Subsidiary and each other newly-designated Unrestricted.

Subsidiary being concurrently redesignated would be permitted to be made by the covenant described under “— Limitation on Restricted Payments” (other than any Investment deemed to have been made by the Company or any Restricted Subsidiary in the Colour Life Group upon the designation of the Colour Life Group as Unrestricted Subsidiaries in connection with the proposed Colour Life IPO, *provided* that (i) the Board of Directors of the Company has determined in good faith that the designation of the Subsidiaries in the Colour Life Group as Unrestricted Subsidiaries is necessary to obtain approval from a Qualified Exchange for the proposed Colour Life IPO, and (ii) immediately prior to the designation of the Colour Life Group as Unrestricted Subsidiaries, the Consolidated Assets of the Colour Life Group shall be no more than 5% of the Total Assets of the Company).

The Board of Directors may designate any Unrestricted Subsidiary to be a Restricted Subsidiary; *provided* that (1) no Default shall have occurred and be continuing at the time of or after giving effect to such designation; (2) any Indebtedness of such Unrestricted Subsidiary outstanding at the time of such designation which will be deemed to have been Incurred by such newly-designated Restricted Subsidiary as a result of such designation would be permitted to be Incurred by the covenant described under the caption “— Limitation on Indebtedness and Preferred Stock;” (3) any Lien on the property of such Unrestricted Subsidiary at the time of such designation which will be deemed to have been incurred by such newly-designated Restricted Subsidiary as a result of such designation would be permitted to be incurred by the covenant described under the caption “— Limitation on Liens;” (4) such Unrestricted Subsidiary is not a Subsidiary of another Unrestricted Subsidiary (that is not concurrently being designated as a Restricted Subsidiary); (5) if such Restricted Subsidiary is not organized under the laws of the PRC, such Restricted Subsidiary shall upon such designation execute and deliver to the Trustee a supplemental indenture to the Indenture by which such Restricted Subsidiary shall become a Subsidiary Guarantor or a JV Subsidiary Guarantor; and (6) if such Restricted Subsidiary is not organized under the laws of the PRC, all Capital Stock of such Restricted Subsidiary owned by the Company or any other Restricted Subsidiary shall be pledged as required under “— Security”.

#### ***Government Approvals and Licenses; Compliance with Law***

The Company will, and will cause each Restricted Subsidiary to, (1) obtain and maintain in full force and effect all governmental approvals, authorizations, consents, permits, concessions and licenses as are necessary to engage in the Permitted Businesses; (2) preserve and maintain good and valid title to its properties and assets (including land-use rights) free and clear of any Liens other than Permitted Liens; and (3) comply with all laws, regulations, orders, judgments and decrees of any governmental body, except to the extent that failure so to obtain, maintain, preserve and comply would not reasonably be expected to have a material adverse effect on (a) the business, results of operations or prospects of the Company and its Restricted Subsidiaries, taken as a whole, or (b) the ability of the Company, any Subsidiary Guarantor or any JV Subsidiary Guarantor to perform its obligations under the Notes, the relevant Subsidiary Guarantee, the relevant JV Subsidiary Guarantee or the Indenture.

#### ***Anti-Layering***

The Company will not Incur, and will not permit any Subsidiary Guarantor or JV Subsidiary Guarantor to Incur, any Indebtedness if such Indebtedness is contractually subordinated in right of payment to any other Indebtedness of the Company, such Subsidiary Guarantor or such JV Subsidiary Guarantor, as the case may be, unless such Indebtedness is also contractually subordinated in right of payment to the Notes, the applicable Subsidiary Guarantee or the applicable JV Subsidiary Guarantee, on substantially identical terms. This does not apply to distinctions between categories of Indebtedness that exist by reason of any Liens or Guarantees securing or in favor of some but not all of such Indebtedness.

### ***Suspension of Certain Covenants***

If, on any date following the date of the Indenture, the Notes have a rating of Investment Grade from both of the Rating Agencies and no Default has occurred and is continuing (a “Suspension Event”), then, beginning on that day and continuing until such time, if any, at which the Notes cease to have a rating of Investment Grade from either of the Rating Agencies, the provisions of the Indenture summarized under the following captions will be suspended:

- (1) “— Certain Covenants — Limitation on Indebtedness and Preferred Stock”;
- (2) “— Certain Covenants — Limitation on Restricted Payments”;
- (3) “— Certain Covenants — Limitation on Dividend and Other Payment Restrictions Affecting Restricted Subsidiaries”;
- (4) “— Certain Covenants — Limitation on Sales and Issuances of Capital Stock in Restricted Subsidiaries”;
- (5) “— Certain Covenants — Limitation on Issuances of Guarantees by Restricted Subsidiaries”;
- (6) “— Certain Covenants — Limitation on the Company’s Business Activities”;
- (7) “— Certain Covenants — Limitation on Sale and Leaseback Transactions”; and
- (8) “— Certain Covenants — Limitation on Asset Sales”.

During any period that the foregoing covenants have been suspended, the Board of Directors may not designate any of the Restricted Subsidiaries as Unrestricted Subsidiaries pursuant to the covenant summarized under the caption “— Certain Covenants — Designation of Restricted and Unrestricted Subsidiaries” or the definition of “Unrestricted Subsidiary.”

Such covenants will be reinstated and apply according to their terms as of and from the first day on which a Suspension Event ceases to be in effect. Such covenants will not, however, be of any effect with regard to actions of the Company or any Restricted Subsidiary properly taken in compliance with the provisions of the Indenture during the continuance of the Suspension Event, and following reinstatement the calculations under the covenant summarized under “— Certain Covenants — Limitation on Restricted Payments” will be made as if such covenant had been in effect since the date of the Indenture except that no Default will be deemed to have occurred solely by reason of a Restricted Payment made while that covenant was suspended. There can be no assurance that the Notes will ever achieve a rating of Investment Grade or that any such rating will be maintained.

### ***Provision of Financial Statements and Reports***

- (1) So long as any of the Notes remain outstanding, the Company will file with the Trustee and furnish to the Holders upon request, as soon as they are available but in any event not more than 10 calendar days after they are filed with The Stock Exchange of Hong Kong Limited or any other recognized exchange on which the Company’s ordinary shares are at any time listed for trading, true and correct copies of any financial or other report in the English language filed with such exchange; *provided* that if at any time the Common Stock of the Company ceases to be listed for trading on a recognized stock exchange, the Company will file with the Trustee and furnish to the Holders:
  - (a) as soon as they are available, but in any event within 90 calendar days after the end of the fiscal year of the Company, copies of its financial statements (on a consolidated basis) in respect of such financial year (including a statement of income, balance sheet and cash flow statement) audited by a member firm of an internationally-recognized firm of independent accountants;



- (b) as soon as they are available, but in any event within 45 calendar days after the end of the second financial quarter of the Company, copies of its financial statements (on a consolidated basis) in respect of such half-year period (including a statement of income, balance sheet and cash flow statement) reviewed by a member firm of an internationally-recognized firm of independent accountants; and
  - (c) as soon as they are available, but in any event within 45 calendar days after the end of each of the first and third financial quarter of the Company, copies of its unaudited financial statements (on a consolidated basis), including a statement of income, balance sheet and cash flow statement, prepared on a basis consistent with the audited financial statements of the Company together with a certificate signed by the person then authorized to sign financial statements on behalf of the Company to the effect that such financial statements are true in all material respects and present fairly the financial position of the Company as at the end of, and the results of its operations for, the relevant quarterly period.
- (2) In addition, so long as any of the Notes remain outstanding, the Company will provide to the Trustee (a) within 120 days after the close of each fiscal year, an Officers' Certificate stating the Fixed Charge Coverage Ratio with respect to the two most recent fiscal semiannual periods and showing in reasonable detail the calculation of the Fixed Charge Coverage Ratio, including the arithmetic computations of each component of the Fixed Charge Coverage Ratio, with a certificate from the Company's external auditors verifying the accuracy and correctness of the calculation and arithmetic computation, *provided* that the Company shall not be required to provide such auditor certification if its external auditors refuse to provide such certification as a result of a policy of such external auditors not to provide such certification; and (b) as soon as possible and in any event within 30 days after the Company becomes aware or should reasonably become aware of the occurrence of a Default, an Officers' Certificate setting forth the details of the Default, and the action which the Company proposes to take with respect thereto.

### **Events of Default**

The following events will be defined as "Events of Default" in the Indenture:

- (1) default in the payment of principal of (or premium, if any, on) the Notes when the same becomes due and payable at maturity, upon acceleration, redemption or otherwise;
- (2) default in the payment of interest on any Note when the same becomes due and payable, and such default continues for a period of 30 consecutive days;
- (3) default in the performance or breach of the provisions of the covenants described under "— Consolidation, Merger and Sale of Assets," the failure by the Company to make or consummate an Offer to Purchase in the manner described under the captions "— Repurchase of Notes upon a Change of Control Triggering Event" or "— Limitation on Asset Sales," or the failure by the Company to create, or cause its Restricted Subsidiaries to create, a Lien on the Collateral (subject to any Permitted Liens) in accordance with the covenant described under the caption "— Security;"
- (4) the Company or any Restricted Subsidiary defaults in the performance of or breaches any other covenant or agreement in the Indenture or under the Notes (other than a default specified in clause (1), (2) or (3) above) and such default or breach continues for a period of 30 consecutive days after written notice by the Trustee or the Holders of 25% or more in aggregate principal amount of the Notes;
- (5) there occurs with respect to any Indebtedness of the Company or any Restricted Subsidiary having an outstanding principal amount of US\$5.0 million (or the Dollar Equivalent thereof) or more in the aggregate for all such Indebtedness of all such Persons, whether such Indebtedness

- now exists or shall hereafter be created, (a) an event of default that has caused the holder thereof to declare such Indebtedness to be due and payable prior to its Stated Maturity and/or (b) the failure to make a principal payment when due;
- (6) one or more final judgments or orders for the payment of money are rendered against the Company or any of its Restricted Subsidiaries and are not paid or discharged, and there is a period of 60 consecutive days following entry of the final judgment or order that causes the aggregate amount for all such final judgments or orders outstanding and not paid or discharged against all such Persons to exceed US\$5.0 million (or the Dollar Equivalent thereof) (in excess of amounts which the Company's insurance carriers have agreed to pay under applicable policies) during which a stay of enforcement, by reason of a pending appeal or otherwise, is not in effect;
  - (7) an involuntary case or other proceeding is commenced against the Company or any Restricted Subsidiary with respect to it or its debts under any applicable bankruptcy, insolvency or other similar law now or hereafter in effect seeking the appointment of a receiver, liquidator, assignee, custodian, trustee, sequestrator or similar official of the Company or any Restricted Subsidiary or for any substantial part of the property and assets of the Company or any Restricted Subsidiary and such involuntary case or other proceeding remains undismissed and unstayed for a period of 60 consecutive days; or an order for relief is entered against the Company or any Restricted Subsidiary under any applicable bankruptcy, insolvency or other similar law as now or hereafter in effect;
  - (8) the Company or any Restricted Subsidiary (a) commences a voluntary case under any applicable bankruptcy, insolvency or other similar law now or hereafter in effect, or consents to the entry of an order for relief in an involuntary case under any such law, (b) consents to the appointment of or taking possession by a receiver, liquidator, assignee, custodian, trustee, sequestrator or similar official of the Company or any Restricted Subsidiary or for all or substantially all of the property and assets of the Company or any Restricted Subsidiary or (c) effects any general assignment for the benefit of creditors;
  - (9) any Subsidiary Guarantor or JV Subsidiary Guarantor denies or disaffirms its obligations under its Subsidiary Guarantee or JV Subsidiary Guarantee or, except as permitted by the Indenture, any Subsidiary Guarantee or JV Subsidiary Guarantee is determined to be unenforceable or invalid or shall for any reason cease to be in full force and effect;
  - (10) any default by the Company or any Subsidiary Guarantor Pledgor in the performance of any of its obligations under the Security Documents, which adversely affects the enforceability, validity, perfection or priority of the applicable Lien on the Collateral or which adversely affects the condition or value of the Collateral, taken as a whole, in any material respect; or
  - (11) the Company or any Subsidiary Guarantor Pledgor denies or disaffirms its obligations under any Security Document or, other than in accordance with the Indenture and the Security Documents, any Security Document ceases to be or is not in full force and effect or the Trustee ceases to have a security interest in the Collateral (subject to any Permitted Liens).

If an Event of Default (other than an Event of Default specified in clause (7) or (8) above) occurs and is continuing under the Indenture, the Trustee or the Holders of at least 25% in aggregate principal amount of the Notes then outstanding, by written notice to the Company (and to the Trustee if such notice is given by the Holders), may, and the Trustee at the request of such Holders shall, declare the principal of, premium, if any, and accrued and unpaid interest on the Notes to be immediately due and payable. Upon a declaration of acceleration, such principal of, premium, if any, and accrued and unpaid interest shall be immediately due and payable. If an Event of Default specified in clause (7) or (8) above occurs with respect to the Company or any Restricted Subsidiary, the principal of, premium, if any, and accrued and unpaid interest on the Notes then outstanding shall automatically become and be immediately due and payable without any declaration or other act on the part of the Trustee or any Holder.

The Holders of at least a majority in principal amount of the outstanding Notes by written notice to the Company and to the Trustee may on behalf of the Holders of Notes waive all past defaults and rescind and annul a declaration of acceleration and its consequences if:

- (1) all existing Events of Default, other than the nonpayment of the principal of, premium, if any, and interest on the Notes that have become due solely by such declaration of acceleration, have been cured or waived, and
- (2) the rescission would not conflict with any judgment or decree of a court of competent jurisdiction.

Upon such waiver, the Default will cease to exist, and any Event of Default arising therefrom will be deemed to have been cured, but no such waiver will extend to any subsequent or other Default or impair any right consequent thereon.

If an Event of Default occurs and is continuing, the Trustee may pursue, in its own name or as trustee of an express trust, any available remedy by proceeding at law or in equity to collect the payment of principal of and interest on the Notes or to enforce the performance of any provision of the Notes or the Indenture. The Trustee may maintain a proceeding even if it does not possess any of the Notes or does not produce any of them in the proceeding. In addition, if an Event of Default occurs and is continuing, the Trustee may, and shall upon request of Holders of at least 25% in aggregate principal amount of outstanding Notes, foreclose on the Collateral in accordance with the terms of the Security Documents and take such further action on behalf of the Holders of the Notes with respect to the Collateral as the Trustee deems appropriate. See “— Security.”

The Holders of at least a majority in aggregate principal amount of the outstanding Notes may direct the time, method and place of conducting any proceeding for any remedy available to the Trustee or exercising any trust or power conferred on the Trustee. However, the Trustee may refuse to follow any direction that conflicts with law or the Indenture, that may involve the Trustee in personal liability, or that the Trustee determines in good faith may be unduly prejudicial to the rights of Holders not joining in the giving of such direction and may take any other action it deems proper that is not inconsistent with any such direction received from Holders.

A Holder of Notes may not institute any proceeding, judicial or otherwise, with respect to the Indenture or the Notes, or for the appointment of a receiver or trustee, or for any other remedy under the Indenture or the Notes, unless:

- (1) the Holder has previously given the Trustee written notice of a continuing Event of Default;
- (2) the Holders of at least 25% in aggregate principal amount of outstanding Notes make a written request to the Trustee to pursue the remedy;
- (3) such Holder or Holders offer the Trustee indemnity reasonably satisfactory to the Trustee against any costs, liability or expense to be incurred in compliance with such request;
- (4) the Trustee does not comply with the request within 60 days after receipt of the request and the offer of indemnity; and
- (5) during such 60-day period, the Holders of a majority in aggregate principal amount of the outstanding Notes do not give the Trustee a direction that is inconsistent with the request.

However, such limitations do not apply to the right of any Holder to receive payment of the principal of, premium, if any, or interest on, such Note, or to bring suit for the enforcement of any such payment, on or after the due date expressed in the Notes, which right shall not be impaired or affected without the consent of the Holder.

Officers of the Company must certify, on or before a date not more than 120 days after the end of each fiscal year, that a review has been conducted of the activities of the Company and its Restricted Subsidiaries and the Company's and its Restricted Subsidiaries' performance under the Indenture and that the Company has fulfilled all obligations thereunder, or, if there has been a default in the fulfillment of any such obligation, specifying each such default and the nature and status thereof. The Company will also be obligated to notify the Trustee of any default or defaults in the performance of any covenants or agreements under the Indenture. See "— Provision of Financial Statements and Reports."

### **Consolidation, Merger and Sale of Assets**

The Company will not consolidate with, merge with or into another Person, permit any Person to merge with or into it, or sell, convey, transfer, lease or otherwise dispose of all or substantially all of its and its Restricted Subsidiaries' properties and assets (computed on a consolidated basis) (as an entirety or substantially an entirety in one transaction or a series of related transactions), unless:

- (1) the Company shall be the continuing Person, or the Person (if other than it) formed by such consolidation or merger or that acquired or leased such property and assets (the "Surviving Person") shall be a corporation organized and validly existing under the laws of the Cayman Islands, Hong Kong or the British Virgin Islands and shall expressly assume, by a supplemental indenture to the Indenture, executed and delivered to the Trustee, all the obligations of the Company under the Indenture, the Notes and the Security Documents, as the case may be, including the obligation to pay Additional Amounts with respect to any jurisdiction in which it is organized or resident for tax purposes or through which it makes payments, and the Indenture, the Notes and the Security Documents, as the case may be, shall remain in full force and effect;
- (2) immediately after giving effect to such transaction, no Default shall have occurred and be continuing;
- (3) immediately after giving effect to such transaction on a pro forma basis, the Company or the Surviving Person, as the case may be, shall have a Consolidated Net Worth equal to or greater than the Consolidated Net Worth of the Company immediately prior to such transaction;
- (4) immediately after giving effect to such transaction on a pro forma basis the Company or the Surviving Person, as the case may be, could Incur at least US\$1.00 of Indebtedness under the first paragraph of the covenant under the caption "— Limitation on Indebtedness and Preferred Stock;"
- (5) the Company delivers to the Trustee (x) an Officers' Certificate (attaching the arithmetic computations to demonstrate compliance with clauses (3) and (4)) and (y) an Opinion of Counsel, in each case stating that such consolidation, merger or transfer and the relevant supplemental indenture complies with this provision and that all conditions precedent provided for in the Indenture relating to such transaction have been complied with;
- (6) each Subsidiary Guarantor and JV Subsidiary Guarantor, unless such Subsidiary Guarantor or JV Subsidiary Guarantor is the Person with which the Company has entered into a transaction described under the caption "— Consolidation, Merger and Sale of Assets," shall execute and deliver a supplemental indenture to the Indenture confirming that its Subsidiary Guarantee or JV Subsidiary Guarantee, as applicable, shall apply to the obligations of the Company or the Surviving Person in accordance with the Notes and the Indenture; and
- (7) no Rating Decline shall have occurred.

No Subsidiary Guarantor or JV Subsidiary Guarantor will consolidate with, merge with or into another Person, permit any Person to merge with or into it, or sell, convey, transfer, lease or otherwise dispose of all or substantially all of its and its Restricted Subsidiaries' properties and assets (computed on a consolidated basis) (as an entirety or substantially an entirety in one transaction or a series of related transactions) to another Person (other than the Company or another Subsidiary Guarantor or, in the case of a JV Subsidiary Guarantor, other than to another JV Subsidiary Guarantor, the Company or a Subsidiary Guarantor), unless:

- (1) such Subsidiary Guarantor or JV Subsidiary Guarantor shall be the continuing Person, or the Person (if other than it) formed by such consolidation or merger or that acquired or leased such property and assets shall be the Company, another Subsidiary Guarantor or shall become a Subsidiary Guarantor concurrently with the transaction (or, in the case of a JV Subsidiary Guarantor, another JV Subsidiary Guarantor, the Company or a Subsidiary Guarantor); and shall expressly assume, by a supplemental indenture to the Indenture, executed and delivered to the Trustee, all the obligations of such Subsidiary Guarantor or JV Subsidiary Guarantor under the Indenture, the Notes and the Security Documents, as the case may be, including the obligation to pay Additional Amounts with respect to any jurisdiction in which it is organized or resident for tax purposes or through which it makes payments, and the Indenture, the Notes and the Security Documents, as the case may be, shall remain in full force and effect;
- (2) immediately after giving effect to such transaction, no Default shall have occurred and be continuing;
- (3) immediately after giving effect to such transaction on a pro forma basis, the Company shall have a Consolidated Net Worth equal to or greater than the Consolidated Net Worth of the Company immediately prior to such transaction;
- (4) immediately after giving effect to such transaction on a pro forma basis, the Company could Incur at least US\$1.00 of Indebtedness under the first paragraph of the covenant under the caption “— Limitation on Indebtedness and Preferred Stock;”
- (5) the Company delivers to the Trustee (x) an Officers' Certificate (attaching the arithmetic computations to demonstrate compliance with clauses (3) and (4)) and (y) an Opinion of Counsel, in each case stating that such consolidation, merger or transfer and the relevant supplemental indenture complies with this provision and that all conditions precedent provided for in the Indenture relating to such transaction have been complied with; and
- (6) no Rating Decline shall have occurred;

*provided* that this paragraph shall not apply to any sale or other disposition that complies with the “— Limitation on Asset Sales” covenant or any Subsidiary Guarantor or JV Subsidiary Guarantor whose Subsidiary Guarantee or JV Subsidiary Guarantee, as the case may be, is unconditionally released in accordance with the provisions described under “— The Subsidiary Guarantees — Release of the Subsidiary Guarantees.”

The foregoing requirements shall not apply to a consolidation or merger of any Subsidiary Guarantor or JV Subsidiary Guarantor with and into the Company or any other Subsidiary Guarantor or JV Subsidiary Guarantor, so long as the Company or such Subsidiary Guarantor or JV Subsidiary Guarantor survives such consolidation or merger.

The foregoing provisions would not necessarily afford Holders protection in the event of highly-leveraged or other transactions involving the Company that may adversely affect Holders.

## **No Payments for Consents**

The Company will not, and shall not permit any of its Subsidiaries to, directly or indirectly, pay or cause to be paid any consideration, whether by way of interest, fee or otherwise, to any Holder for or as an inducement to any consent, waiver or amendment of any of the terms or provisions of the Indenture or the Notes unless such consideration is offered to be paid or is paid to all Holders that consent, waive or agree to amend such term or provision within the time period set forth in the solicitation documents relating to such consent, waiver or amendment.

## **Defeasance**

### *Defeasance and Discharge*

The Indenture will provide that the Company will be deemed to have paid and will be discharged from any and all obligations in respect of the Notes on the 183rd day after the deposit referred to below, and the provisions of the Indenture and the Security Documents will no longer be in effect with respect to the Notes (except for, among other matters, certain obligations to register the transfer or exchange of the Notes, to replace stolen, lost or mutilated Notes, to maintain paying agencies, to pay Additional Amounts and to hold monies for payment in trust) if, among other things:

- (1) the Company (a) has deposited with the Trustee (or its agent), in trust, cash in Renminbi in an amount sufficient to pay the principal of, premium, if any, and accrued interest on the Notes on the Stated Maturity for such payments in accordance with the terms of the Indenture and the Notes and (b) delivers to the Trustee an Opinion of Counsel or a certificate of an internationally-recognized firm of independent accountants to the effect that the amount deposited by the Company is sufficient to provide payment for the principal of, premium, if any, and accrued interest on, the Notes on the Stated Maturity for such payment in accordance with the terms of the Indenture;
- (2) the Company has delivered to the Trustee an Opinion of Counsel of recognized international standing to the effect that the creation of the defeasance trust does not violate the U.S. Investment Company Act of 1940, as amended, and after the passage of 123 days following the deposit, the trust fund will not be subject to the effect of Section 547 of the United States Bankruptcy Code or Section 15 of the New York Debtor and Creditor Law; and
- (3) immediately after giving effect to such deposit on a pro forma basis, no Event of Default, or event that after the giving of notice or lapse of time or both would become an Event of Default, shall have occurred and be continuing on the date of such deposit or during the period ending on the 183rd day after the date of such deposit, and such defeasance shall not result in a breach or violation of, or constitute a default under, any other agreement or instrument to which the Company or any of its Restricted Subsidiaries is a party or by which the Company or any of its Restricted Subsidiaries is bound.

In the case of either discharge or defeasance of the Notes, the Subsidiary Guarantees and JV Subsidiary Guarantees will terminate.

### ***Defeasance of Certain Covenants***

The Indenture further will provide that the provisions of the Indenture applicable to the Notes will no longer be in effect with respect to clauses (3), (4), (5)(x) and (7) under the first paragraph, and clauses (3), (4), (5)(x) and (6) under the second paragraph under “— Consolidation, Merger and Sale of Assets” and all the covenants described herein under “— Certain Covenants,” other than as described under “— Certain Covenants-Government Approvals and Licenses; Compliance with Law” and “— Certain Covenants-Anti-Layering,” clause (3) under “Events of Default” with respect to clauses (3), (4), (5)(x) and (7) under the first paragraph, and clauses (3), (4), (5)(x) and (6) under the second paragraph under “Consolidation, Merger and Sale of Assets” and with respect to the other events set forth in such clause, clause (4) under “Events of Default” with respect to such other covenants and clauses (5) and (6) under “Events of Default” shall be deemed not to be Events of Default upon, among other things, the deposit with the Trustee (or its agent), in trust, of cash in Renminbi in an amount sufficient to pay the principal of, premium, if any, and accrued interest on the Notes on the Stated Maturity of such payments in accordance with the terms of the Indenture and the Notes, the satisfaction of the provisions described in clause (2) of the preceding paragraph.

### **Amendments and Waiver**

#### ***Amendments Without Consent of Holders***

The Indenture, the Intercreditor Agreement or any Security Document may be amended, without the consent of any Holder, to:

- (1) cure any ambiguity, defect, omission or inconsistency in the Indenture, the Notes, the Intercreditor Agreement or any Security Document;
- (2) comply with the provisions described under “— Consolidation, Merger and Sale of Assets;”
- (3) evidence and provide for the acceptance of appointment by a successor Trustee;
- (4) add any Subsidiary Guarantor or JV Subsidiary Guarantor, or any Subsidiary Guarantee or JV Subsidiary Guarantee, or release any Subsidiary Guarantor or JV Subsidiary Guarantor from any Subsidiary Guarantee or JV Subsidiary Guarantee, as the case may be, as provided or permitted by the terms of the Indenture;
- (5) provide for the issuance of Additional Notes in accordance with the limitations set forth in the Indenture;
- (6) add any Subsidiary Guarantor Pledgor or release any Subsidiary Guarantor Pledgor and the corresponding Collateral as provided or permitted by the terms of the Indenture;
- (7) add additional Collateral to secure the Notes, any Subsidiary Guarantee or any JV Subsidiary Guarantee;
- (8) in any other case where a supplemental indenture to the Indenture is required or permitted to be entered into pursuant to the provisions of the Indenture without the consent of any Holder;
- (9) effect any changes to the Indenture in a manner necessary to comply with the procedures of CMU or any applicable clearing system;
- (10) permit Permitted Pari Passu Secured Indebtedness (including, without limitation, permitting the Trustee to supplement or amend the Intercreditor Agreement, the Security Documents or the Indenture and take any other action necessary to permit the creation and registration of Liens on the Collateral to secure Permitted Pari Passu Secured Indebtedness, in accordance with the Indenture); or
- (11) make any other change that does not materially and adversely affect the rights of any Holder.

### *Amendments With Consent of Holders*

The Indenture, the Intercreditor Agreement or any Security Document may be amended with the consent of the Holders of not less than a majority in aggregate principal amount of the outstanding Notes and the Agents may amend or waive future compliance by the Company with any provision thereof; *provided, however*, that no such modification, amendment or waiver may, without the consent of each Holder affected thereby:

- (1) change the Stated Maturity of the principal of, or any installment of interest on, any Note;
- (2) reduce the principal amount of, or premium, if any, or interest on, any Note;
- (3) change the currency of payment of principal of, or premium, if any, or interest on, any Note;
- (4) impair the right to institute suit for the enforcement of any payment on or after the Stated Maturity (or, in the case of a redemption, on or after the redemption date) of any Note;
- (5) reduce the above-stated percentage of outstanding Notes the consent of whose Holders is necessary to modify or amend the Indenture;
- (6) waive a default in the payment of principal of, premium, if any, or interest on the Notes;
- (7) release any Subsidiary Guarantor or JV Subsidiary Guarantor from its Subsidiary Guarantee or JV Subsidiary Guarantee, as the case may be, except as provided in the Indenture;
- (8) release any Collateral, except as provided in the Intercreditor Agreement, the Indenture and the Security Documents;
- (9) reduce the percentage or aggregate principal amount of outstanding Notes the consent of whose Holders is necessary for waiver of compliance with certain provisions of the Indenture or for waiver of certain defaults;
- (10) amend, change or modify any Subsidiary Guarantee or JV Subsidiary Guarantee in a manner that adversely affects the Holders;
- (11) amend, change or modify any provision of the Intercreditor Agreement, any Security Document or the Indenture relating to the Collateral, in a manner that adversely affects the Holders, except in accordance with the other provisions of the Indenture;
- (12) reduce the amount payable upon a Change of Control Offer or an Offer to Purchase with the Excess Proceeds from any Asset Sale or, change the time or manner by which a Change of Control Offer or an Offer to Purchase with the Excess Proceeds or other proceeds from any Asset Sale may be made or by which the Notes must be repurchased pursuant to a Change of Control Offer or an Offer to Purchase with the Excess Proceeds or other proceeds from any Asset Sale;
- (13) change the redemption date or the redemption price of the Notes from that stated under the captions “— Optional Redemption” or “— Redemption for Taxation Reasons;”
- (14) amend, change or modify the obligation of the Company or any Subsidiary Guarantor or any JV Subsidiary Guarantor to pay Additional Amounts; or
- (15) amend, change or modify any provision of the Indenture or the related definition affecting the ranking of the Notes, any Subsidiary Guarantee or any JV Subsidiary Guarantee in a manner which adversely affects the Holders.



## **Unclaimed Money**

Claims against the Company for the payment of principal of, premium, if any, or interest, on the Notes will become void unless presentation for payment is made as required in the Indenture within a period of six years.

## **No Personal Liability of Incorporators, Stockholders, Officers, Directors or Employees**

No recourse for the payment of the principal of, premium, if any, or interest on any of the Notes or for any claim based thereon or otherwise in respect thereof, and no recourse under or upon any obligation, covenant or agreement of the Company, any of the Subsidiary Guarantors or any of the JV Subsidiary Guarantors in the Indenture, or in any of the Notes, the Subsidiary Guarantees or the JV Subsidiary Guarantees, or because of the creation of any Indebtedness represented thereby, shall be had against any incorporator, stockholder, officer, director, employee or controlling person of the Company, any of the Subsidiary Guarantors or JV Subsidiary Guarantors, or of any successor Person thereof. Each Holder, by accepting the Notes, waives and releases all such liability. The waiver and release are part of the consideration for the issuance of the Notes, the Subsidiary Guarantees and the JV Subsidiary Guarantees. Such waiver may not be effective to waive liabilities under the federal securities laws.

## **Concerning the Agents**

Citicorp International Limited has been appointed as Trustee under the Indenture and as Collateral Agent with respect to the Collateral under the Intercreditor Agreement and other Security Documents. Citicorp International Limited has also been appointed as note registrar (the “Note Registrar”), paying agent (the “Paying Agent”) and CMU lodging agent (the “CMU Lodging Agent” and, together with the Trustee, the Note Registrar and the Paying Agent, the “Agents”) with regard to the Notes. Except during the continuance of a Default, the Trustee will not be liable, except for the performance of such duties as are specifically set forth in the Indenture. If an Event of Default has occurred and is continuing, the Trustee will use the same degree of care and skill in its exercise of the rights and powers vested in it under the Indenture as a prudent person would exercise under the circumstances in the conduct of such person’s own affairs.

The Indenture contains limitations on the rights of the Trustee, should it become a creditor of the Company or any of the Subsidiary Guarantors, to obtain payment of claims in certain cases or to realize on certain property received by it in respect of any such claims, as security or otherwise. The Trustee is permitted to engage in other transactions, including normal banking and trustee relationships, with the Company and its Affiliates; *provided, however*, that if it acquires any conflicting interest, it must eliminate such conflict or resign.

None of the Trustee, the Paying Agent, the Note Registrar, or the Collateral Agent nor any of its officers, directors, employees, attorneys or agents will be responsible or liable for the existence, genuineness, value or protection of any Collateral securing the Notes, for the legality, enforceability, effectiveness or sufficiency of the Intercreditor Agreement or other Security Documents, for the creation, perfection, priority, sufficiency or protection of any of the Liens, or for any defect or deficiency as to any such matters, or for any failure to demand, collect, foreclose or realize upon or otherwise enforce any of the Liens or Security Documents or any delay in doing so, except as a result of the Agent’s own fraud, gross negligence or willful misconduct.

Citicorp International Limited will initially act as Trustee and the Collateral Agent under the Security Documents in respect of the Lien over the Collateral. The Trustee, acting in its capacity as such, shall have such duties with respect to the Collateral pledged, assigned or granted pursuant to the Security Documents as are set forth in the Indenture and the Security Documents. Under certain circumstances, the Trustee and the Collateral Agent may have obligations under the Intercreditor Agreement or other Security Documents that are in conflict with the interests of the Holders and the holders (or their representatives) of Permitted Pari Passu Secured Indebtedness (if any). Neither the Trustee nor the Collateral Agent will be under any obligation to exercise any rights or powers conferred under the Indenture or any of the Security Documents for the benefit of the Holders or the holders (or their representatives) of Permitted Pari Passu Secured Indebtedness (if any), unless such Holders and/or the holders (or their representatives) of Permitted Pari Passu Secured Indebtedness (if any) have offered to the Trustee and/or the Collateral Agent indemnity and/or security satisfactory to the Trustee and/or the Collateral Agent against any loss, liability or expense.

If the Company maintains a paying agent with respect to the Notes in a member state of the European Union, such paying agent will be located in a member state of the European Union that is not obligated to withhold or deduct tax pursuant to European Council Directive 2003/48/EC or any other directive implementing the conclusions of ECOFIN Council meeting of November 26–27, 2000 on the taxation of savings income, or any law implementing or complying with, or introduced in order to conform to, such Directive or such other directive.

Citicorp International Limited will initially act as the Collateral Agent under the Security Documents in respect of the security over the Collateral. The Collateral Agent, acting in its capacity as such, shall have such duties with respect to the Collateral pledged, assigned or granted pursuant to the Security Documents as are set forth in the Indenture, the Intercreditor Agreement and the Security Documents. Under certain circumstances, the Collateral Agent may have obligations under the Security Documents, the Indenture or the Intercreditor Agreement that are in conflict with the interests of the Trustee, the Holders, the trustee for the 2010 Notes, the holders of the 2010 Notes and the holders (or their representatives) of Permitted Pari Passu Secured Indebtedness (if any). Neither the Trustee nor the Collateral Agent will be under any obligation to exercise any rights or powers conferred under the Indenture, the Intercreditor Agreement or any other Security Document for the benefit of the Holders or the holders (or their representatives) of Permitted Pari Passu Secured Indebtedness (if any), unless such Holders and/or the holders (or their representatives) of Permitted Pari Passu Secured Indebtedness (if any) have offered to the Trustee and/or the Collateral Agent indemnity and/or security satisfactory to it against any loss, liability or expense. Furthermore, each Holder, by accepting the Notes will agree, for the benefit of the Trustee and the Collateral Agent, that it is solely responsible for its own independent appraisal of and investigation into all risks arising under or in connection with the Security Documents and has not relied on and will not at any time rely on the Trustee or the Collateral Agent in respect of such risks.

### **Book-Entry; Delivery and Form**

The Notes will initially be issued in registered form and represented by a global certificate (the “Global Note”) registered in the name of a nominee of, and shall be delivered to and held by, a sub-custodian nominated by the Hong Kong Monetary Authority as operator (the “Operator”) of the Central Moneymarkets Unit Service (“CMU”). The Global Note will be held for the account of CMU members who have accounts with the Operator, or the CMU participants. For persons seeking to hold a beneficial interest in the Notes through Euroclear or Clearstream, such persons will hold their interests through an account opened and held by Euroclear or Clearstream with the Operator. Interests in the Global Note will only be shown on, and transfers of interests will be effected through, records maintained by the Operator.

For so long as any of the Notes are represented by a Global Note, each person who is for the time being shown in the records of the Operator as the holder of a particular principal amount of Note (the “account holder”) (in which regard any certificate or other document issued by the Operator as to the principal amount of such Notes standing to the account of any person shall be conclusive and binding for all purposes except in the case of manifest error) shall be treated by the Company, the Trustee, the Paying Agent, Note Registrar and the Operator as the holder of such principal amount of such Notes for all purposes other than with respect to the payment of principal or interest on the Notes, the right to which shall be vested, as against the Company, the Trustee, the Paying Agent, Note Registrar and the Operator solely in the Holder of the Global Note in accordance with and subject to its terms (and the expressions “Holder” and “holder of Notes” and related expressions shall be construed accordingly).

Notwithstanding the above, if the Global Note is held by or on behalf of the CMU, any payments that are made in respect of the Global Note shall be made to the account holder and such payments shall discharge the obligation of the Company in respect of that payment. For these purposes, a notification from the CMU shall be conclusive evidence of the records of the CMU (save in the case of manifest error).

Exchanges of the holding of Notes represented by the Global Note for a Certificated Note in the denomination of CNY1,000,000 each and integral multiples of CNY100,000 in excess thereof without coupons may only be made in whole but not in part:

- (a) if the Notes represented by the Global Note are held on behalf of the CMU or any other clearing system, in addition to or in substitution for the CMU on whose behalf the Global Note is for the time being held and CMU and/or any such clearing system is closed for business for a continuous period of 14 days (other than by reason of holidays, statutory or otherwise) or announces an intention permanently to cease business or does in fact do so; or
- (b) any of the Notes has become immediately due and payable pursuant to the terms of the Indenture and the Company has received a written request from a Holder.

Since the Operator can act only on behalf of the CMU participants, who in turn may act on behalf of persons who hold interests through them, or indirect participants, the ability of persons having interests in a Global Note to pledge such interests to persons or entities that are not CMU participants, or otherwise take action in respect of such interests, may be affected by the lack of definitive Notes.

While the Global Note representing the Notes is held by or on behalf of the Operator, payments of interest or principal will be made to the persons for whose account a relevant interest in the Global Note is credited as being held by the Operator at the relevant time, as notified to the Paying Agent and Note Registrar by the Operator in a relevant CMU instrument position report or in any other relevant notification by the Operator. Such payment will discharge the Company’s obligations in respect of that payment. Any payments by the CMU participants to indirect participants will be governed by arrangements agreed between the CMU participants and the indirect participants and will continue to depend on the inter-bank clearing system and traditional payment methods. Such payments will be the sole responsibility of such CMU participants.

Payments, transfers, exchanges and other matters relating to interests in the Global Note may be subject to various policies and procedures adopted by the Operator from time to time. None of the Company, the Trustee, the Initial Purchasers, the Paying Agent and Note Registrar or any of their respective agents will have any responsibility or liability for any aspect of the Operator’s records relating to, or for payments made on account of, interests in a Global Note, or for maintaining, supervising or reviewing any records relating to such interests.

The Operator is under no obligation to maintain or continue to operate the CMU and the Operator is under no obligation to perform or continue to perform the procedures described above.

Accordingly, the CMU and such procedures may be discontinued or modified at any time. None of the Company, the Trustee, the Initial Purchasers, the Paying Agent and Note Registrar nor any of their respective agents will have any responsibility for the performance by the Operator or the CMU participants of their respective obligations under the rules and procedures governing their operations.

### **Transfers**

A Note may be transferred by delivery of the certificate issued in respect of that Note, with the form of transfer on the back duly completed and signed by the Holder or his attorney duly authorized in writing, to the specified office of the Note Registrar or any of the other Agents. No transfer of a Note will be valid unless and until entered on the Note register.

Transfers of interests in the Notes evidenced by a Global Note will be effected in accordance with the rules of the CMU. So long as the Notes are represented by the Global Note and the CMU so permits, transfers of interests in the Notes through the CMU shall be in principal amounts of at least CNY1,000,000 and integral multiples of CNY100,000 in excess thereof. Further, the Notes will be traded on the SGX-ST in a minimum board lot size of CNY200,000 with a minimum of six lots to be traded in a single transaction for as long as the Notes are listed on the SGX-ST.

### **Notices**

All notices or demands required or permitted by the terms of the Notes or the Indenture to be given to or by the Holders are required to be in writing and may be given or served by being sent by prepaid courier or first-class mail, if intended for the Company, any Subsidiary Guarantor or any JV Subsidiary Guarantor, addressed to the Company at F/27, Block A, Hailun Complex, No. 6021 Shennan Boulevard, Shenzhen 518040, Guangdong Province, China, attention: LAM Kam Tong, Company Secretary, or if intended for the Trustee, the Paying Agent or the Note Registrar, addressed to the Trustee, the Paying Agent or the Note Registrar, as the case may be, at the corporate trust office of the Trustee; and, if intended for any Holder, addressed to such Holder at such Holder's last address as it appears in the Note register and shall be deemed to have been given on the fourth weekday (being a day other than a Saturday or a Sunday) after the date of mailing. The Company shall also ensure that notices are duly published in a manner that complies with the rules and regulations of any stock exchange or other relevant authority on which the Notes are for the time being listed. Any such notice shall be deemed to have been given on the date of such publication or, if published more than once, on the first date on which publication is made. For so long as the Global Note is held on behalf of the Operator, any notice to holders of the Notes will be validly given by delivery to the persons shown in a CMU instrument position report issued by the Operator on the Business Day preceding the date of despatch of such notice as holding interests in the Global Note.

Indirect participants will have to rely on the CMU participants (through whom they hold the Notes, in the form of interests in a Global Note) to deliver the notices to them, subject to the arrangements agreed between the indirect participants and the CMU participants.

### **Currency Fallback**

Notwithstanding all other provisions, if by reason of Inconvertibility, Non-transferability or Illiquidity, the Company or the relevant Subsidiary Guarantor is not able, or it would be impracticable for it, to satisfy payments of principal or interest (in whole or in part) in respect of Notes when due in Renminbi in Hong Kong, the Company or such Subsidiary Guarantor may, on giving not less than five or more than 30 days' irrevocable notice to the Holders prior to the due date for payment, settle any such payment (in whole or in part) in U.S. dollars on the due date at the Renminbi amount converted into U.S. dollars using the Spot Rate for the relevant Rate Calculation Date ("U.S. Dollar Equivalent") of any such Renminbi denominated amount.

In such event, payments of the U.S. Dollar Equivalent of the relevant principal or interest in respect of the Notes shall be made by a U.S. dollar denominated check drawn on a bank in New York City and

mailed to the Holder (or to the first named of joint Holders) of the Notes at its address appearing in the Note register, or, upon application by the Holder to the specified office of the Note Registrar or any other Agent before the Record Date, by transfer to a U.S. dollar denominated account with a bank in New York City.

All notifications, determinations, certificates, calculations and quotations given, expressed, made or obtained for the purposes of this provision by the Paying Agent, will (in the absence of willful default, bad faith or manifest error) be binding the Company, the Subsidiary Guarantors, the Trustee, the other Agents and all Holders.

### **Currency Indemnity**

Subject to the provisions under “Currency Fallback,” the Renminbi is the sole currency of account and payment for all sums payable by the Company under or in connection with the Notes, including damages. Any amount received or recovered in a currency other than Renminbi (whether as a result of, or of the enforcement of, a judgment or order of a court of any jurisdiction, in the insolvency, winding-up or dissolution of the Company or otherwise) by any Holder in respect of any sum expressed to be due to it from the Company shall only constitute a discharge to the Company to the extent of the Renminbi amount which the recipient is able to purchase with the amount so received or recovered in that other currency on the date of that receipt or recovery (or, if it is not practicable to make that purchase on that date, on the first date on which it is practicable to do so). If that Renminbi amount is less than the Renminbi amount expressed to be due to the recipient under any Note, the Company shall indemnify it against any loss sustained by it as a result. In any event, the Company shall indemnify the recipient against the cost of making any such purchase. For the purposes of this provision, it will be sufficient for the Holder to demonstrate that it would have suffered a loss had an actual purchase been made. These indemnities constitute a separate and independent obligation from the Company’s other obligations, shall give rise to a separate and independent cause of action, shall apply irrespective of any indulgence granted by any Holder and shall continue in full force and effect despite any other judgment, order, claim or proof for a liquidated amount in respect of any sum due under any Note or any other judgment or order.

### **Consent to Jurisdiction; Service of Process**

The Company and each of the Subsidiary Guarantors will irrevocably (1) submit to the non exclusive jurisdiction of any U.S. federal or New York state court located in the Borough of Manhattan, The City of New York in connection with any suit, action or proceeding arising out of, or relating to, the Notes, any Subsidiary Guarantee, any JV Subsidiary Guarantee, the Indenture or any transaction contemplated thereby; and (2) designate and appoint National Corporate Research, Ltd. for receipt of service of process in any such suit, action or proceeding.

### **Governing Law**

Each of the Notes, the Subsidiary Guarantees, the JV Subsidiary Guarantees and the Indenture provides that such instrument will be governed by, and construed in accordance with, the laws of the State of New York. The relevant pledge documents pursuant to “— Security” will be governed under the laws of the jurisdiction in which the relevant Subsidiary Guarantor is incorporated.

### **Definitions**

Set forth below are defined terms used in the covenants and other provisions of the Indenture. Reference is made to the Indenture for other capitalized terms used in this “Description of the Notes” for which no definition is provided.

“2010 Notes” means 14% Senior Notes due 2015 of the Company.

“2012 Notes” means 13.75% Senior Notes due 2017 of the Company.

“Acquired Indebtedness” means Indebtedness of a Person existing at the time such Person becomes a Restricted Subsidiary or Indebtedness of a Restricted Subsidiary assumed in connection with an Asset Acquisition by such Restricted Subsidiary whether or not Incurred in connection with, or in contemplation of, the Person merging with or into or becoming a Restricted Subsidiary.

“Affiliate” means, with respect to any Person, any other Person (1) directly or indirectly controlling, controlled by, or under direct or indirect common control with, such Person; (2) who is a director or officer of such Person or any Subsidiary of such Person or of any Person referred to in clause (1) of this definition; or (3) who is a spouse or any person cohabiting as a spouse, child or step-child, parent or step-parent, brother, sister, step-brother or step-sister, parent-in-law, grandchild, grandparent, uncle, aunt, nephew and niece of a Person described in clause (1) or (2). For purposes of this definition, “control” (including, with correlative meanings, the terms “controlling,” “controlled by” and “under common control with”), as applied to any Person, means the possession, directly or indirectly, of the power to direct or cause the direction of the management and policies of such Person, whether through the ownership of voting securities, by contract or otherwise.

“Applicable Premium” means with respect to any Note at any redemption date, the excess of (A) the present value at such redemption date of the principal amount of such Note, plus all required remaining scheduled interest payments due on such Note through the maturity date of the Notes (but excluding accrued and unpaid interest to the redemption date), computed using a discount rate of 2% per annum, over (B) the principal amount of such Note on such redemption date.

“Asset Acquisition” means (1) an investment by the Company or any of its Restricted Subsidiaries in any other Person pursuant to which such Person shall become a Restricted Subsidiary or shall be merged into or consolidated with the Company or any of its Restricted Subsidiaries; or (2) an acquisition by the Company or any of its Restricted Subsidiaries of the property and assets of any Person other than the Company or any of its Restricted Subsidiaries that constitute substantially all of a division or line of business of such Person.

“Asset Disposition” means the sale or other disposition by the Company or any of its Restricted Subsidiaries (other than to the Company or another Restricted Subsidiary) of (1) all or substantially all of the Capital Stock of any Restricted Subsidiary; or (2) all or substantially all of the assets that constitute a division or line of business of the Company or any of its Restricted Subsidiaries.

“Asset Sale” means any sale, transfer or other disposition (including by way of merger, consolidation or Sale and Leaseback Transaction) of any of its property or assets (including any sale of Capital Stock of a Subsidiary or issuance of Capital Stock by a Restricted Subsidiary) in one transaction or a series of related transactions by the Company or any of its Restricted Subsidiaries to any Person; *provided* that “Asset Sale” shall not include:

- (1) sales or other dispositions of inventory, receivables and other current assets (including properties under development for sale and completed properties for sale) in the ordinary course of business;
- (2) sales, transfers or other dispositions of assets constituting a Permitted Investment or Restricted Payment permitted to be made under the “— Limitation on Restricted Payments” covenant;
- (3) sales, transfers or other dispositions of assets with a Fair Market Value not in excess of US\$1 million (or the Dollar Equivalent thereof) in any transaction or series of related transactions;
- (4) any sale, transfer, assignment or other disposition of any property, or equipment that has become damaged, worn out, obsolete or otherwise unsuitable for use in connection with the business of the Company or its Restricted Subsidiaries;
- (5) any transfer, assignment or other disposition deemed to occur in connection with creating or granting any Permitted Lien;
- (6) a transaction covered by the covenant under the caption “— Consolidation, Merger and Sale of Assets;” and

- (7) any sale, transfer or other disposition by the Company or any of its Restricted Subsidiaries, including the sale or issuance by the Company or any Restricted Subsidiary of any Capital Stock of any Restricted Subsidiary, to the Company or any Restricted Subsidiary.

“Attributable Indebtedness” means, in respect of a Sale and Leaseback Transaction, the present value, discounted at the interest rate implicit in the Sale and Leaseback Transaction, of the total obligations of the lessee for rental payments during the remaining term of the lease in the Sale and Leaseback Transaction.

“Average Life” means, at any date of determination with respect to any Indebtedness, the quotient obtained by dividing (1) the sum of the products of (a) the number of years from such date of determination to the dates of each successive scheduled principal payment of such Indebtedness and (b) the amount of such principal payment by (2) the sum of all such principal payments.

“Bank Deposit Secured Indebtedness” means Indebtedness of the Company or any Restricted Subsidiary that is secured by a pledge of one or more bank accounts of the Company or a Restricted Subsidiary and is used by the Company and its Restricted Subsidiaries to in effect exchange currency.

“Board of Directors” means the board of directors elected or appointed by the stockholders of the Company to manage the business of the Company or any committee of such board duly authorized to take the action purported to be taken by such committee.

“Board Resolution” means any resolution of the Board of Directors taking an action which it is authorized to take and adopted at a meeting duly called and held at which a quorum of disinterested members (if so required) was present and acting throughout or adopted by written resolution executed by every member of the Board of Directors.

“Business Day” means a day (other than a Saturday, Sunday or public holiday) on which commercial banks are generally open (a) for business and settlement of Renminbi payments in Hong Kong, (b) in the city in which the specified office of the relevant Paying Agent is located and (c) in the case of the surrender of a Certificated Note, in the place where the Certificated Note is surrendered.

“Capitalized Lease” means, with respect to any Person, any lease of any property (whether real, personal or mixed) which, in conformity with GAAP, is required to be capitalized on the balance sheet of such Person.

“Capitalized Lease Obligations” means the discounted present value of the rental obligations under a Capitalized Lease.

“Capital Stock” means, with respect to any Person, any and all shares, interests, participations or other equivalents (however designated, whether voting or non-voting) in equity of such Person, whether outstanding on the Original Issue Date or issued thereafter, including, without limitation, all Common Stock and Preferred Stock, but excluding debt securities convertible into such equity.

“Change of Control” means the occurrence of one or more of the following events:

- (1) the merger, amalgamation or consolidation of the Company with or into another Person or the merger or amalgamation of another Person with or into the Company, or the sale of all or substantially all the assets of the Company to another Person;
- (2) the Permitted Holders are the beneficial owners of less than 50% of the total voting power of the Voting Stock of the Company;
- (3) any “person” or “group” (as such terms are used in Sections 13(d) and 14(d) of the U.S. Exchange Act) is or becomes the “beneficial owner” (as such term is used in Rule 13d-3 of the U.S. Exchange Act), directly or indirectly, of total voting power of the Voting Stock of the Company greater than such total voting power held beneficially by the Permitted Holders;

- (4) individuals who on the Original Issue Date constituted the board of directors of the Company, together with any new directors whose election by the board of directors was approved by a vote of at least two-thirds of the directors then still in office who were either directors or whose election was previously so approved, cease for any reason to constitute a majority of the board of directors of the Company then in office; or
- (5) the adoption of a plan relating to the liquidation or dissolution of the Company.

“Change of Control Triggering Event” means the occurrence of both a Change of Control and a Rating Decline.

“Clearstream” means Clearstream Banking, société anonyme, Luxembourg.

“Collateral” means all collateral securing, or purported to be securing, directly or indirectly, the Notes, any Subsidiary Guarantee or any JV Subsidiary Guarantee pursuant to the Security Documents, and shall initially consist of the Capital Stock of the initial Subsidiary Guarantors.

“Collateral Agent” means Citicorp International Limited.

“Colour Life Group” means the group of Subsidiaries of the Company which are solely engaged in property management, property services and ancillary property community businesses.

“Colour Life IPO” means the restructuring and Qualified IPO of the ordinary shares of a Subsidiary of the Company in the Colour Life Group.

“Commodity Hedging Agreement” means any spot, forward or option commodity price protection agreements or other similar agreement or arrangement designed to protect against fluctuations in commodity prices.

“Common Stock” means, with respect to any Person, any and all shares, interests or other participations in, and other equivalents (however designated and whether voting or non-voting) of such Person’s common stock or ordinary shares, whether or not outstanding at the date of the Indenture, and include, without limitation, all series and classes of such common stock or ordinary shares.

“Consolidated Assets” means, with respect to any Restricted Subsidiary at any date of determination, the Company and its Restricted Subsidiaries’ proportionate interest in the total consolidated assets of such Restricted Subsidiary and its Restricted Subsidiaries measured in accordance with GAAP as of the last day of the most recent semi-annual period for which consolidated financial statements of the Company and its Restricted Subsidiaries (which the Company shall use its best efforts to compile on a timely manner) are available (which may be internal consolidated financial statements).

“Consolidated EBITDA” means, for any period, Consolidated Net Income for such period plus, to the extent such amount was deducted in calculating such Consolidated Net Income:

- (1) Consolidated Interest Expense,
- (2) income taxes (other than income taxes attributable to extraordinary and non-recurring gains (or losses) or sales of assets), and
- (3) depreciation expense, amortization expense and all other non-cash items reducing Consolidated Net Income (other than non-cash items in a period which reflect cash expenses paid or to be paid in another period), less all non-cash items increasing Consolidated Net Income,

all as determined on a consolidated basis for the Company and its Restricted Subsidiaries in conformity with GAAP; *provided* that (1) if any Restricted Subsidiary is not a Wholly Owned Restricted Subsidiary, Consolidated EBITDA shall be reduced (to the extent not otherwise reduced in accordance



with GAAP) by an amount equal to (A) the amount of the Consolidated Net Income attributable to such Restricted Subsidiary multiplied by (B) the percentage ownership interest in the income of such Restricted Subsidiary not owned on the last day of such period by the Company or any of its Restricted Subsidiaries and (2) in the case of any future PRC CJV (consolidated in accordance with GAAP), Consolidated EBITDA shall be reduced (to the extent not already reduced in accordance with GAAP) by any payments, distributions or amounts (including the Fair Market Value of any non-cash payments, distributions or amounts) required to be made or paid by such PRC CJV to the PRC CJV Partner, or to which the PRC CJV Partner otherwise has a right or is entitled, pursuant to the joint venture agreement governing such PRC CJV.

“Consolidated Fixed Charges” means, for any period, the sum (without duplication) of (1) Consolidated Interest Expense for such period and (2) all cash and non-cash dividends paid, declared, accrued or accumulated during such period on any Disqualified Stock or Preferred Stock of the Company or any Restricted Subsidiary held by Persons other than the Company or any Wholly Owned Restricted Subsidiary, except for dividends payable in the Company’s Capital Stock (other than Disqualified Stock) or paid to the Company or to a Wholly Owned Restricted Subsidiary.

“Consolidated Interest Expense” means, for any period, the amount that would be included in gross interest expense on a consolidated income statement prepared in accordance with GAAP for such period of the Company and its Restricted Subsidiaries, plus, to the extent not included in such gross interest expense, and to the extent incurred, accrued or payable during such period by the Company and its Restricted Subsidiaries, without duplication, (1) interest expense attributable to Capitalized Lease Obligations, (2) amortization of debt issuance costs and original issue discount expense and non-cash interest payments in respect of any Indebtedness, (3) the interest portion of any deferred payment obligation, (4) all commissions, discounts and other fees and charges with respect to letters of credit or similar instruments issued for financing purposes or in respect of any Indebtedness, (5) the net costs associated with Hedging Obligations (including the amortization of fees), (6) interest accruing on Indebtedness of any other Person that is Guaranteed by the Company or any Restricted Subsidiary (other than Pre-Registration Mortgage Guarantees) and (7) any capitalized interest, *provided* that interest expense attributable to interest on any Indebtedness bearing a floating interest rate will be computed on a pro forma basis as if the rate in effect on the date of determination had been the applicable rate for the entire relevant period.

“Consolidated Net Income” means, with respect to any specified Person for any period, the aggregate of the net income (or loss) of such Person and its Restricted Subsidiaries for such period, on a consolidated basis, determined in conformity with GAAP; *provided* that the following items shall be excluded in computing Consolidated Net Income (without duplication):

- (1) the net income (or loss) of any Person that is not a Restricted Subsidiary or that is accounted for by the equity method of accounting except that:
  - (a) subject to the exclusion contained in clause (5) below, the Company’s equity in the net income of any such Person for such period shall be included in such Consolidated Net Income up to the aggregate amount of cash actually distributed by such Person during such period to the Company or a Restricted Subsidiary as a dividend or other distribution (subject, in the case of a dividend or other distribution paid to a Restricted Subsidiary, to the limitations contained in clause (3) below); and
  - (b) the Company’s equity in a net loss of any such Person for such period shall be included in determining such Consolidated Net Income to the extent funded with cash or other assets of the Company or Restricted Subsidiaries;
- (2) the net income (or loss) of any Person accrued prior to the date it becomes a Restricted Subsidiary or is merged into or consolidated with the Company or any of its Restricted Subsidiaries or all or substantially all of the property and assets of such Person are acquired by the Company or any of its Restricted Subsidiaries;
- (3) the net income (but not loss) of any Restricted Subsidiary to the extent that the declaration or payment of dividends or similar distributions by such Restricted Subsidiary of such net income

is not at the time permitted by the operation of the terms of its charter, articles of association or other similar constitutive documents, or any agreement, instrument, judgment, decree, order, statute, rule or governmental regulation applicable to such Restricted Subsidiary;

- (4) the cumulative effect of a change in accounting principles;
- (5) any net after tax gains realized on the sale or other disposition of (a) any property or assets of the Company or any Restricted Subsidiary which is not sold in the ordinary course of its business or (b) any Capital Stock of any Person (including any gains by the Company realized on sales of Capital Stock of the Company or other Restricted Subsidiaries);
- (6) any translation gains and losses due solely to fluctuations in currency values and related tax effects; and
- (7) any net after-tax extraordinary or non-recurring gains.

“Consolidated Net Worth” means, at any date of determination, stockholders’ equity as set forth on the most recently available semi-annual or annual consolidated balance sheet of the Company and its Restricted Subsidiaries, plus, to the extent not included, any Preferred Stock of the Company, less any amounts attributable to Disqualified Stock or any equity security convertible into or exchangeable for Indebtedness, the cost of treasury stock and the principal amount of any promissory notes receivable from the sale of the Capital Stock of the Company or any of its Restricted Subsidiaries, each item to be determined in conformity with GAAP.

“Contractor Guarantees” means any Guarantee by the Company or any Restricted Subsidiary of Indebtedness of any contractor, builder or other similar Person engaged by the Company or such Restricted Subsidiary in connection with the development, construction or improvement of real or personal property or equipment to be used in a Permitted Business by the Company or any Restricted Subsidiary in the ordinary course of business, which Indebtedness was Incurred by such contractor, builder or other similar Person to finance the cost of such development, construction or improvement.

“Currency Agreement” means any foreign exchange forward contract, currency swap agreement or other similar agreement or arrangement designed to protect against fluctuations in foreign exchange rates.

“Default” means any event that is, or after notice or passage of time or both would be, an Event of Default.

“Disqualified Stock” means any class or series of Capital Stock of any Person that by its terms or otherwise is (1) required to be redeemed prior to the date that is 183 days after the Stated Maturity of the Notes, (2) redeemable at the option of the holder of such class or series of Capital Stock at any time prior to the date that is 183 days after the Stated Maturity of the Notes or (3) convertible into or exchangeable for Capital Stock referred to in clause (1) or (2) above or Indebtedness having a scheduled maturity prior to the Stated Maturity of the Notes; *provided* that any Capital Stock that would not constitute Disqualified Stock but for provisions thereof giving holders thereof the right to require such Person to repurchase or redeem such Capital Stock upon the occurrence of an “asset sale” or “change of control” occurring prior to the Stated Maturity of the Notes shall not constitute Disqualified Stock if the “asset sale” or “change of control” provisions applicable to such Capital Stock are no more favorable to the holders of such Capital Stock than the provisions contained in the “— Limitation on Asset Sales” and “— Repurchase of Notes upon a Change of Control Triggering Event” covenants and such Capital Stock specifically provides that such Person will not repurchase or redeem any such stock pursuant to such provision prior to the Company’s repurchase of such Notes as are required to be repurchased pursuant to the “— Limitation on Asset Sales” and “— Repurchase of Notes upon a Change of Control Triggering Event” covenants.

“Dollar Equivalent” means, with respect to any monetary amount in a currency other than U.S. dollars, at any time for the determination thereof, the amount of U.S. dollars obtained by converting such foreign currency involved in such computation into U.S. dollars at the base rate for the purchase of U.S. dollars with the applicable foreign currency as quoted by the Federal Reserve Bank of New York on the date of determination.

“Equity Offering” means (i) any underwritten primary public offering or private placement of Common Stock of the Company after the Original Issue Date or (ii) any underwritten secondary public offering or secondary private placement of Common Stock of the Company beneficially owned by a Permitted Holder, after the Original Issue Date, to the extent that a Permitted Holder or a company controlled by a Permitted Holder concurrently with such public offering or private placement purchases in cash an equal amount of Common Stock from the Company at the same price as the public offering or private placing price; *provided* that any offering or placing referred to in (A) clause (i), (B) clause (ii), or (C) a combination of clauses (i) and (ii) result in the aggregate gross cash proceeds received by the Company being no less than US\$20.0 million (or the Dollar Equivalent thereof).

“Euroclear” means Euroclear Bank S.A./N.V., as operator of the Euroclear System.

“Fair Market Value” means the price that would be paid in an arm’s-length transaction between an informed and willing seller under no compulsion to sell and an informed and willing buyer under no compulsion to buy, as determined in good faith by the Board of Directors, whose determination shall be conclusive if evidenced by a Board Resolution, except in the case of a determination of Fair Market Value of total assets for the purposes of determining a JV Entitlement Amount, in which case such price shall be determined by an accounting, appraisal or investment banking firm of recognized international standing appointed by the Company.

“Fixed Charge Coverage Ratio” means, on any Transaction Date, the ratio of (1) the aggregate amount of Consolidated EBITDA for the then most recent four fiscal quarters periods prior to such Transaction Date for which consolidated financial statements of the Company (which the Company shall use its reasonable best efforts to compile in a timely manner) are available (which may be internal consolidated financial statements) (the “Four Quarter Period”) to (2) the aggregate Consolidated Fixed Charges during such Four Quarter Period. In making the foregoing calculation:

- (a) pro forma effect shall be given to any Indebtedness, Disqualified Stock or Preferred Stock Incurred, repaid or redeemed during the period (the “Reference Period”) commencing on and including the first day of the Four Quarter Period and ending on and including the Transaction Date (other than Indebtedness Incurred or repaid under a revolving credit or similar arrangement (or under any predecessor revolving credit or similar arrangement) in effect on the last day of such Four Quarter Period), in each case as if such Indebtedness, Disqualified Stock or Preferred Stock had been Incurred, repaid or redeemed on the first day of such Reference Period; *provided* that, in the event of any such repayment or redemption, Consolidated EBITDA for such period shall be calculated as if the Company or such Restricted Subsidiary had not earned any interest income actually earned during such period in respect of the funds used to repay such Indebtedness;
- (b) Consolidated Interest Expense attributable to interest on any Indebtedness (whether existing or being Incurred) computed on a pro forma basis and bearing a floating interest rate shall be computed as if the rate in effect on the Transaction Date (taking into account any Interest Rate Agreement applicable to such Indebtedness if such Interest Rate Agreement has a remaining term in excess of 12 months or, if shorter, at least equal to the remaining term of such Indebtedness) had been the applicable rate for the entire period;
- (c) pro forma effect shall be given to the creation, designation or redesignation of Restricted and Unrestricted Subsidiaries as if such creation, designation or redesignation had occurred on the first day of such Reference Period;
- (d) pro forma effect shall be given to Asset Dispositions and Asset Acquisitions (including giving pro forma effect to the application of proceeds of any Asset Disposition) that occur during such Reference Period as if they had occurred and such proceeds had been applied on the first day of such Reference Period; and
- (e) pro forma effect shall be given to asset dispositions and asset acquisitions (including giving pro forma effect to the application of proceeds of any asset disposition) that have been made by any Person that has become a Restricted Subsidiary or has been merged with or into the

Company or any Restricted Subsidiary during such Reference Period and that would have constituted Asset Dispositions or Asset Acquisitions had such transactions occurred when such Person was a Restricted Subsidiary as if such asset dispositions or asset acquisitions were Asset Dispositions or Asset Acquisitions that occurred on the first day of such Reference Period;

*provided* that to the extent that clause (d) or (e) of this sentence requires that pro forma effect be given to an Asset Acquisition or Asset Disposition (or asset acquisition or asset disposition), such pro forma calculation shall be based upon the two full fiscal semi-annual periods immediately preceding the Transaction Date of the Person, or division or line of business of the Person, that is acquired or disposed for which financial information is available.

“GAAP” means generally accepted accounting principles in Hong Kong as in effect from time to time. All ratios and computations contained or referred to in the Indenture shall be computed in conformity with GAAP applied on a consistent basis.

“Governmental Authority” means any de facto or de jure government (or any agency or instrumentality thereof), court, tribunal, administrative or other governmental authority or any other entity (private or public) charged with the regulation of the financial markets (including the central bank) of Hong Kong.

“Guarantee” means any obligation, contingent or otherwise, of any Person directly or indirectly guaranteeing any Indebtedness or other obligation of any other Person and, without limiting the generality of the foregoing, any obligation, direct or indirect, contingent or otherwise, of such Person (1) to purchase or pay (or advance or supply funds for the purchase or payment of) such Indebtedness or other obligation of such other Person (whether arising by virtue of partnership arrangements, or by agreements to keep-well, to purchase assets, goods, securities or services, to take-or-pay, or to maintain financial statement conditions or otherwise) or (2) entered into for purposes of assuring in any other manner the obligee of such Indebtedness or other obligation of the payment thereof or to protect such obligee against loss in respect thereof (in whole or in part), *provided* that the term “Guarantee” shall not include endorsements for collection or deposit in the ordinary course of business. The term “Guarantee” used as a verb has a corresponding meaning.

“Hedging Obligation” of any Person means the obligations of such Person pursuant to any Commodity Hedging Agreement, Currency Agreement or Interest Rate Agreement.

“Holder” means the Person in whose name a Note is registered in the Note register.

“Illiquidity” means the general Renminbi exchange market in Hong Kong becomes illiquid as a result of which the Company or such Subsidiary Guarantor cannot obtain sufficient Renminbi in order to satisfy its obligation to pay interest and principal (in whole or in part) in respect of the Notes.

“Inconvertibility” means the occurrence of any event that makes it impossible for the Company or such Subsidiary Guarantor to convert any amount due in respect of the Notes in the general Renminbi exchange market in Hong Kong, other than where such impossibility is due solely to the failure of the Company or such Subsidiary Guarantor to comply with any law, rule or regulation enacted by any Governmental Authority (unless such law, rule or regulation is enacted after the Original Issue Date and it is impossible for the Company or such Subsidiary Guarantor, due to an event beyond its control, to comply with such law, rule or regulation).

“Incur” means, with respect to any Indebtedness or Capital Stock, to incur, create, issue, assume, Guarantee or otherwise become liable for or with respect to, or become responsible for, the payment of, contingently or otherwise, such Indebtedness or Capital Stock; *provided* that (1) any Indebtedness and Capital Stock of a Person existing at the time such Person becomes a Restricted Subsidiary (or fails to meet the qualifications necessary to remain an Unrestricted Subsidiary) will be deemed to be Incurred by such Restricted Subsidiary at the time it becomes a Restricted Subsidiary and (2) the accretion of original issue discount shall not be considered an Incurrence of Indebtedness. The terms “Incurrence,” “Incurred” and “Incurring” have meanings correlative with the foregoing.

“Indebtedness” means, with respect to any Person at any date of determination (without duplication):

- (1) all indebtedness of such Person for borrowed money;
- (2) all obligations of such Person evidenced by bonds, debentures, notes or other similar instruments;
- (3) all obligations of such Person in respect of letters of credit, bankers’ acceptances or other similar instruments;
- (4) all obligations of such Person to pay the deferred and unpaid purchase price of property or services, except Trade Payables;
- (5) all Capitalized Lease Obligations and Attributable Indebtedness;
- (6) all Indebtedness of other Persons secured by a Lien on any asset of such Person, whether or not such Indebtedness is assumed by such Person; *provided* that the amount of such Indebtedness shall be the lesser of (a) the Fair Market Value of such asset at such date of determination and (b) the amount of such Indebtedness;
- (7) all Indebtedness of other Persons Guaranteed by such Person to the extent such Indebtedness is Guaranteed by such Person;
- (8) to the extent not otherwise included in this definition, Hedging Obligations; and
- (9) all Disqualified Stock issued by such Person valued at the greater of its voluntary or involuntary liquidation preference and its maximum fixed repurchase price plus accrued dividends.

Notwithstanding the foregoing, Indebtedness shall not include any capital commitments, deferred payment obligation, pre-sale receipts in advance from customers or similar obligations Incurred in the ordinary course of business in connection with the acquisition, development, construction or improvement of real or personal property (including land use rights) to be used in a Permitted Business; *provided* that such Indebtedness is not reflected on the balance sheet of the Company or any Restricted Subsidiary (contingent obligations and commitments referred to in a footnote to financial statements and not otherwise reflected as borrowings on the balance sheet will not be deemed to be reflected on such balance sheet).

The amount of Indebtedness of any Person at any date shall be the outstanding balance at such date of all unconditional obligations as described above and, with respect to contingent obligations, the maximum liability upon the occurrence of the contingency giving rise to the obligation; *provided*

- (1) that the amount outstanding at any time of any Indebtedness issued with original issue discount is the face amount of such Indebtedness less the remaining unamortized portion of the original issue discount of such Indebtedness at such time as determined in conformity with GAAP,
- (2) that money borrowed and set aside at the time of the Incurrence of any Indebtedness in order to prefund the payment of the interest on such Indebtedness shall not be deemed to be “Indebtedness” so long as such money is held to secure the payment of such interest, and
- (3) that the amount of Indebtedness with respect to any Hedging Obligation shall be: (i) zero if Incurred pursuant to paragraph (2)(f) under the “Limitation on Indebtedness and Preferred Stock” covenant, and (ii) equal to the net amount payable by such Person if such Hedging Obligation terminated at that time if not Incurred pursuant to such paragraph.

“Independent Third Party” means any Person that is not an Affiliate of the Company.

“Insurance Company Investor” means an Independent Third Party that is an insurance company organized under the laws of the PRC or an Affiliate of such an insurance company that acquires a minority interest in the Capital Stock of a Subsidiary of a PRC Restricted Subsidiary.

“Intercreditor Agreement” has the meaning set forth under “— Security.”

“Interest Payment Business Day” means a day (other than a Saturday, Sunday or public holiday) on which commercial banks are generally open for business and settlement of Renminbi payments in Hong Kong.

“Interest Rate Agreement” means any interest rate protection agreement, interest rate future agreement, interest rate option agreement, interest rate swap agreement, interest rate cap agreement, interest rate collar agreement, interest rate hedge agreement, option or future contract or other similar agreement or arrangement designed to protect against fluctuations in interest rates.

“Investment” means:

- (1) any direct or indirect advance, loan or other extension of credit to another Person;
- (2) any capital contribution to another Person (by means of any transfer of cash or other property to others or any payment for property or services for the account or use of others);
- (3) any purchase or acquisition of Capital Stock, Indebtedness, bonds, notes, debentures or other similar instruments or securities issued by another Person; or
- (4) any Guarantee of any obligation of another Person to the extent such obligation is outstanding and to the extent guaranteed by such Person.

For the purposes of the provisions of the “Designation of Restricted and Unrestricted Subsidiaries” and “Limitation on Restricted Payments” covenants: (1) the Company will be deemed to have made an Investment in an Unrestricted Subsidiary in an amount equal to the Company’s proportional interest in the Fair Market Value of the assets (net of the Company’s proportionate interest in the liabilities owed to any Person other than the Company or a Restricted Subsidiary and that are not Guaranteed by the Company or a Restricted Subsidiary) of a Restricted Subsidiary that is designated an Unrestricted Subsidiary at the time of such designation, and (2) any property transferred to or from any Person shall be valued at its Fair Market Value at the time of such transfer, as determined in good faith by the Board of Directors.

“Investment Grade” means a rating of “AAA,” “AA,” “A” or “BBB,” as modified by a “+” or “-” indication, or an equivalent rating representing one of the four highest rating categories, by S&P or any of its successors or assigns or a rating of “Aaa,” or “Aa,” “A” or “Baa,” as modified by a “1,” “2” or “3” indication, or an equivalent rating representing one of the four highest rating categories, by Moody’s, or any of its successors or assigns or the equivalent ratings of any internationally recognized rating agency or agencies, as the case may be, which shall have been designated by the Company as having been substituted for S&P or Moody’s or both, as the case may be.

“January 2013 Notes” means 10.75% Senior Notes due 2020 of the Company.

“JV Entitlement Amount” means, with respect to any JV Subsidiary Guarantor and its Subsidiaries, an amount that is equal to the product of (i) the Fair Market Value of the total assets of such JV Subsidiary and its Subsidiaries, on a consolidated basis (without deducting any Indebtedness or other liabilities of such JV Subsidiary Guarantor and its subsidiaries) as of the date of the last fiscal year end of the Company; and (ii) a percentage equal to the direct equity ownership percentage of the Company and/or its Restricted Subsidiaries in the Capital Stock of such JV Subsidiary Guarantor and its Subsidiaries.

“JV Subsidiary Guarantee” has the meaning set forth under the caption “— The Subsidiary Guarantees.”

“JV Subsidiary Guarantor” means a Restricted Subsidiary that executes a JV Subsidiary Guarantee.

“Lien” means any mortgage, pledge, security interest, encumbrance, lien or charge of any kind (including, without limitation, any conditional sale or other title retention agreement or lease in the nature thereof or any agreement to create any mortgage, pledge, security interest, lien, charge, easement or encumbrance of any kind).

“Measurement Date” means May 12, 2010.

“Moody’s” means Moody’s Investors Service, Inc. and its successors.

“Net Cash Proceeds” means:

- (1) with respect to any Asset Sale, the proceeds of such Asset Sale in the form of cash or cash equivalents, including payments in respect of deferred payment obligations (to the extent corresponding to the principal, but not interest, component thereof) when received in the form of cash or cash equivalents and proceeds from the conversion of other property received when converted to cash or cash equivalents, net of:
  - (a) brokerage commissions and other fees and expenses (including fees and expenses of counsel and investment banks) related to such Asset Sale;
  - (b) provisions for all taxes (whether or not such taxes will actually be paid or are payable) as a result of such Asset Sale without regard to the consolidated results of operations of the Company and its Restricted Subsidiaries, taken as a whole;
  - (c) payments made to repay Indebtedness or any other obligation outstanding at the time of such Asset Sale that either (x) is secured by a Lien on the property or assets sold or (y) is required to be paid as a result of such sale;
  - (d) appropriate amounts to be provided by the Company or any Restricted Subsidiary as a reserve against any liabilities associated with such Asset Sale, including, without limitation, pension and other post-employment benefit liabilities, liabilities related to environmental matters and liabilities under any indemnification obligations associated with such Asset Sale, all as determined in conformity with GAAP; and
- (2) with respect to any issuance or sale of Capital Stock, the proceeds of such issuance or sale in the form of cash or cash equivalents, including payments in respect of deferred payment obligations (to the extent corresponding to the principal, but not interest, component thereof) when received in the form of cash or cash equivalents and proceeds from the conversion of other property received when converted to cash or cash equivalents, net of attorneys’ fees, accountants’ fees, underwriters’ or placement agents’ fees, discounts or commissions and brokerage, consultant and other fees incurred in connection with such issuance or sale and net of taxes paid or payable as a result thereof.

“Non-Guaranteed Portion” means, at any time of determination with respect to all of the JV Subsidiary Guarantors then existing and their respective Restricted Subsidiaries, the aggregate value (without duplication) of the equity interests held by each Independent Third Party in any JV Subsidiary Guarantor as determined by multiplying (x) the total assets as shown on the balance sheet of the relevant JV Subsidiary Guarantor for its most recently ended semi-annual period (or, in the case of the JV Subsidiary Guarantor executing such JV Subsidiary Guarantee and any other Restricted Subsidiary of the Company that became a JV Subsidiary Guarantor after the end of the most recently ended semi-annual period, as shown on the balance sheet of such JV Subsidiary Guarantor after giving pro forma effect to the sale or issuance of Capital Stock to the relevant Independent Third Parties) by (y) the proportionate ownership of all Capital Stock held by such Independent Third Party in such JV Subsidiary Guarantor, *provided* that (A) assets attributable to any Unrestricted Subsidiary of such JV Subsidiary Guarantor and (B) assets which would be eliminated from the calculation of Total Assets of the Company for the relevant semi-annual period shall be excluded from the calculation of total assets in clause (x) above.

“Non-transferability” means the occurrence of any event that makes it impossible for the Company or such Subsidiary Guarantor to deliver Renminbi between accounts inside Hong Kong or from an account inside Hong Kong to an account outside Hong Kong, other than where such impossibility is due solely to the failure of the Company or such Subsidiary Guarantor to comply with any law, rule or regulation enacted by any Governmental Authority (unless such law, rule or regulation is enacted after the Original Issue Date and it is impossible for the Company or such Subsidiary Guarantor, due to an event beyond its control, to comply with such law, rule or regulation).

“Offer to Purchase” means an offer to purchase Notes by the Company from the Holders commenced by the Company mailing a notice by first class mail, postage prepaid, to the Trustee, the Paying Agent and Note Registrar and each Holder at its last address appearing in the Note register stating:

- (1) the covenant pursuant to which the offer is being made and that all Notes validly tendered will be accepted for payment on a pro rata basis;
- (2) the purchase price and the date of purchase (which shall be a Business Day no earlier than 30 days nor later than 60 days from the date such notice is mailed) (the “Offer to Purchase Payment Date”);
- (3) that any Note not tendered will continue to accrue interest pursuant to its terms;
- (4) that, unless the Company defaults in the payment of the purchase price, any Note accepted for payment pursuant to the Offer to Purchase shall cease to accrue interest on and after the Offer to Purchase Payment Date;
- (5) that Holders electing to have a Note purchased pursuant to the Offer to Purchase will be required to surrender the Note, together with the form entitled “Option of the Holder to Elect Purchase” on the reverse side of the Note completed, to the Paying Agent at the address specified in the notice prior to the close of business on the Business Day immediately preceding the Offer to Purchase Payment Date;
- (6) that Holders will be entitled to withdraw their election if the Paying Agent receives, not later than the close of business on the third Business Day immediately preceding the Offer to Purchase Payment Date, a facsimile transmission or letter setting forth the name of such Holder, the principal amount of Notes delivered for purchase and a statement that such Holder is withdrawing his election to have such Notes purchased; and
- (7) that Holders whose Notes are being purchased only in part will be issued new Notes equal in principal amount to the unpurchased portion of the Notes surrendered; *provided* that each Note purchased and each new Note issued shall be in a principal amount of CNY1,000,000 or integral multiples of CNY100,000.

On the Offer to Purchase Payment Date, the Company shall (a) accept for payment on a pro rata basis Notes or portions thereof tendered pursuant to an Offer to Purchase; (b) deposit with the Paying Agent money sufficient to pay the purchase price of all Notes or portions thereof so accepted; and (c) deliver, or cause to be delivered, to the Trustee all Notes or portions thereof so accepted together with an Officers’ Certificate specifying the Notes or portions thereof accepted for payment by the Company. The Paying Agent shall promptly mail to the Holders of Notes so accepted payment in an amount equal to the purchase price, and the Trustee or an authenticating agent shall promptly authenticate and mail to such Holders a new Note equal in principal amount to any unpurchased portion of the Note surrendered; *provided* that each Note purchased and each new Note issued shall be in a principal amount of CNY1,000,000 or integral multiples of CNY100,000. The Company will publicly announce the results of an Offer to Purchase as soon as practicable after the Offer to Purchase Payment Date. The Company will comply with Rule 14e-1 under the U.S. Exchange Act and any other securities laws and regulations thereunder to the extent such laws and regulations are applicable, in the event that the Company is required to repurchase Notes pursuant to an Offer to Purchase.

The offer is required to contain or incorporate by reference information concerning the business of the Company and its Subsidiaries which the Company in good faith believes will assist such Holders to make an informed decision with respect to the Offer to Purchase, including a brief description of the events requiring the Company to make the Offer to Purchase, and any other information required by applicable law to be included therein. The offer is required to contain all instructions and materials necessary to enable such Holders to tender Notes pursuant to the Offer to Purchase.

“Officer” means one of the executive officers of the Company or, in the case of a Subsidiary Guarantor or JV Subsidiary Guarantor, one of the directors or officers of such Subsidiary Guarantor or JV Subsidiary Guarantor, as the case may be.



“Officers’ Certificate” means a certificate signed by two Officers; *provided, however*, with respect to the Officers’ Certificate required to be delivered by any Subsidiary Guarantor under this Indenture, Officers’ Certificate means a certificate signed by one Officer if there is only one Officer in such Subsidiary Guarantor at the time such certificate is required to be delivered.

“Opinion of Counsel” means a written opinion from legal counsel who is reasonably acceptable to the Trustee.

“Ordinary Course Operating Lease” means the leases entered into in the ordinary course of its business by Yixing Jiangnan Shuixiang Tourism Resort Co., Ltd. of serviced apartments that have been developed and sold by another Restricted Subsidiary to individual investors for a term of no more than three years, pursuant to which Yixing Jiangnan Shuixiang Tourism Resort Co., Ltd. provides management services for such serviced apartments and retain any rental proceeds from tenants that it finds.

“Original Issue Date” means the date on which the Notes are originally issued under the Indenture.

“Pari Passu Subsidiary Guarantee” means a guarantee by any Subsidiary Guarantor or any JV Subsidiary Guarantor of Indebtedness of the Company (including Additional Notes); *provided* that (1) the Company was permitted to Incur such Indebtedness under the covenant under the caption “— Limitation on Indebtedness and Preferred Stock” and (2) such guarantee ranks *pari passu* with any outstanding Subsidiary Guarantee of such Subsidiary Guarantor, or with any outstanding JV Subsidiary Guarantee of such JV Subsidiary Guarantor, as the case may be.

“Payment Default” means (1) any default in the payment of interest on any Note when the same becomes due and payable, (2) any default in the payment of principal of (or premium, if any, on) the Notes when the same becomes due and payable at maturity, upon acceleration, redemption or otherwise, (3) the failure by the Company to make or consummate a Change of Control Offer in the manner described under the caption “— Repurchase of Notes upon a Change of Control Triggering Event,” or an Offer to Purchase in the manner described under the caption “— Limitation on Asset Sales” or (4) any Event of Default specified in clause (5) of the definition of Events of Default.

“Permitted Businesses” means any business which is the same as or related, ancillary or complementary to any of the businesses of the Company and its Restricted Subsidiaries on the Original Issue Date.

“Permitted Holders” means any or all of the following:

- (1) Pan Jun or Zeng Jie Baby;
- (2) any Affiliate (other than an Affiliate as defined in clause (2) or (3) of the definition of Affiliate) of the Person specified in clause (1); and
- (3) any Person both the Capital Stock and the Voting Stock of which (or in the case of a trust, the beneficial interests in which) are owned 80% by Persons specified in clauses (1) and (2).

“Permitted Investment” means:

- (1) any Investment in the Company or a Restricted Subsidiary that is primarily engaged in a Permitted Business or a Person which will, upon the making of such Investment, become a Restricted Subsidiary that is primarily engaged in a Permitted Business or be merged or consolidated with or into or transfer or convey all or substantially all its assets to, the Company or a Restricted Subsidiary that is primarily engaged in a Permitted Business;
- (2) Temporary Cash Investments;
- (3) payroll, travel and similar advances to cover matters that are expected at the time of such advances ultimately to be treated as expenses in accordance with GAAP;
- (4) stock, obligations or securities received in satisfaction of judgments;

- (5) an Investment in an Unrestricted Subsidiary consisting solely of an Investment in another Unrestricted Subsidiary;
- (6) any Investment pursuant to a Hedging Obligation designed solely to protect the Company or any Restricted Subsidiary against fluctuations in commodity prices, interest rates or foreign currency exchange rates;
- (7) receivables owing to the Company or any Restricted Subsidiary, if created or acquired in the ordinary course of business and payable or dischargeable in accordance with customary trade terms;
- (8) Investments made by the Company or any Restricted Subsidiary consisting of consideration received in connection with an Asset Sale made in compliance with the covenant under the caption “— Limitation on Asset Sales;”
- (9) pledges or deposits (x) with respect to leases or utilities provided to third parties in the ordinary course of business or (y) otherwise described in the definition of “Permitted Liens” or made in connection with Liens permitted under the covenant described under “— Limitation on Liens”;
- (10) any Investment pursuant to Pre-Registration Mortgage Guarantees or Contractor Guarantees by the Company or any Restricted Subsidiary otherwise permitted to be Incurred under the Indenture;
- (11) Investments in securities of trade creditors, trade debtors or customers received pursuant to any plan of reorganization or similar arrangement upon the bankruptcy or insolvency of such trade creditor, trade debtor or customer;
- (12) advances to contractors and suppliers for the acquisition of assets or consumables or services in the ordinary course of business that are recorded as deposits or prepaid expenses on the Company’s consolidated balance sheet;
- (13) deposits of pre-sale proceeds made in order to secure the completion and delivery of pre-sold properties and issuance of the related land use title in the ordinary course of business;
- (14) deposits made in order to comply with statutory or regulatory obligations to maintain deposits for workers compensation claims and other purposes specified by statute or regulation from time to time in the ordinary course of business;
- (15) deposits made in order to secure the performance of the Company or any of its Restricted Subsidiaries and prepayments made in connection with the direct or indirect acquisition of real property or land use rights by the Company or any of its Restricted Subsidiaries, in each case in the ordinary course of business; and
- (16) any Investment by the Company or any Restricted Subsidiary in any corporation, association, or other business entity primarily engaged in a Permitted Business, (i) of which 33 1/3% or more of the Capital Stock and the Voting Stock is owned, directly or indirectly, by the Company or any Restricted Subsidiary and (ii) which is treated as an “associate” or a “jointly controlled entity” in accordance with GAAP (such corporation, association or other business entity, an “Associate”); *provided* that:
  - (a) none of the other holders of Capital Stock of such Associate is a Person described in clauses (x) or (y) of the first paragraph of the covenant described under the caption “— Limitation on Transactions with Shareholders and Affiliates” (other than by reason of such holder being an officer or director of the Company or a Restricted Subsidiary);

- (b) the Company must be able to incur at least US\$1.00 of Indebtedness under the proviso in the first paragraph of the covenant described under the caption “— Limitation on Indebtedness and Preferred Stock;”
  - (c) no Default has occurred and is continuing or would occur as a result of such Investment;
  - (d) such Investment, together with (x) the aggregate of all other Investments made under this clause (16) since the Original Issue Date, less (y) an amount equal to the net reduction in all Investments made under this clause (16) since the Original Issue Date resulting from (A) receipt of payments in cash by the Company or any Restricted Subsidiary in respect of all such Investments, including interest on or repayments of loans or advances, dividends or other distributions (except, in each case, to the extent any such payments are included in the calculation of Consolidated Net Income), (B) the unconditional release of a Guarantee of any obligation of such Associate provided under this clause (16) after the Original Issue Date by the Company or any Restricted Subsidiary, (C) to the extent that an Investment made after the Original Issue Date under this clause (16) is sold or otherwise liquidated or repaid for cash, the lesser of (i) cash return of capital with respect to such Investment (less the cost of disposition, if any) and (ii) the initial amount of such Investment, or (D) such Associate becoming a Restricted Subsidiary (whereupon all Investments (other than Permitted Investments) made by the Company or any Restricted Subsidiary in such Associate since the Original Issue Date shall be deemed to have been made pursuant to clause (1) of this “Permitted Investment” definition), not to exceed, in each case, the amount of Investments (other than Permitted investments) made by the Company or any Restricted Subsidiary after the Original Issue Date in any such Person pursuant to this clause (16), will not exceed an aggregate amount equal to 15% of Total Assets;
  - (e) with respect to such Associate in which the Company or any Restricted Subsidiary has made an Investment pursuant to this clause (16), if (x) the Company or such Restricted Subsidiary no longer owns at least 33 $\frac{1}{3}$ % of the Capital Stock and the Voting Stock of such Associate or such Associate is no longer treated as an “associate” or a “jointly controlled entity” in accordance with GAAP and (y) such Associate has not become a Restricted Subsidiary, such Investment (to the extent such Investment has not been reduced in accordance with this paragraph (d) of this clause (16)) will be deemed not to have been made in accordance with this clause (16) and such Investment must at the time such Associate is no longer treated as an Associate satisfy the other requirements of the covenant described under “— Limitation on Restricted Payments” (including meeting the requirements of one of the other clauses set forth under this “Permitted Investment” definition);
  - (g) if a Restricted Subsidiary is redesignated an Unrestricted Subsidiary, any Investment made by such Restricted Subsidiary pursuant to this clause (16), to the extent such Investment has not been reduced in accordance with paragraph (d) of this clause (16), will be deemed not to have been made in accordance with this clause (16) and such Investment must at the time such Restricted Subsidiary is redesignated an Unrestricted Subsidiary satisfy the other requirements of the covenant described under “— Limitation on Restricted Payments” (including meeting the requirements of any other clauses of this “Permitted Investment” definition); and
- (17) any Investment deemed to have been made by the Company or any Restricted Subsidiary in the Colour Life Group in connection with the Colour Life IPO upon designation of the Subsidiaries in the Colour Life Group as Unrestricted Subsidiaries, *provided* that (A) (i) the Board of Directors of the Company has determined in good faith that the designation of the Subsidiaries in the Colour Life Group as Unrestricted Subsidiaries is necessary to obtain approval from a Qualified Exchange for the Colour Life IPO, (ii) at the time of such designation, the members of the Colour Life Group remain Subsidiaries of the Company, and (iii) at the time of such designation, the members of the Colour Life Group remain primarily

engaged in the Permitted Businesses; and (B) the aggregate of all Investments made under this clause (17) since the Original Issue Date shall not exceed an amount equal to 5% of Total Assets (for the avoidance of doubt, any portion of such Investments exceeding 5% of Total Assets shall not constitute a Permitted Investment pursuant to this item but may be made, characterized and accounted for in accordance with the other provisions of the Indenture); and *provided further* that, at the time when (x) the Company ceases to hold, directly or indirectly, at least 30% of the Voting Stock of any entity so designated as an Unrestricted Subsidiary or (y) any Person or group of Persons other than the Company and its Subsidiaries acquires a higher percentage of the Voting Stock of such entity than the percentage held directly or indirectly by the Company, the Company will be deemed to make an Investment in such entity equal to the Fair Market Value of any Investment that the Company retains, directly or indirectly, in such entity immediately following such event.

“Permitted Liens” means:

- (1) Liens for taxes, assessments, governmental charges or claims that are being contested in good faith by appropriate legal or administrative proceedings promptly instituted and diligently conducted and for which a reserve or other appropriate provision, if any, as shall be required in conformity with GAAP shall have been made;
- (2) statutory and common law Liens of landlords and carriers, warehousemen, mechanics, suppliers, repairmen or other similar Liens arising in the ordinary course of business and with respect to amounts not yet delinquent or being contested in good faith by appropriate legal or administrative proceedings promptly instituted and diligently conducted and for which a reserve or other appropriate provision, if any, as shall be required in conformity with GAAP shall have been made;
- (3) Liens incurred or deposits made to secure the performance of tenders, bids, leases, statutory or regulatory obligations, bankers’ acceptances, surety and appeal bonds, government contracts, performance and return-of-money bonds and other obligations of a similar nature incurred in the ordinary course of business (exclusive of obligations for the payment of borrowed money);
- (4) leases or subleases granted to others that do not materially interfere with the ordinary course of business of the Company and its Restricted Subsidiaries, taken as a whole;
- (5) Liens encumbering property or assets under construction arising from progress or partial payments by a customer of the Company or its Restricted Subsidiaries relating to such property or assets;
- (6) Liens on property of, or on shares of Capital Stock or Indebtedness of, any Person existing at the time such Person becomes, or becomes a part of, any Restricted Subsidiary; *provided* that such Liens do not extend to or cover any property or assets of the Company or any Restricted Subsidiary other than the property or assets acquired; *provided further* that such Liens were not created in contemplation of or in connection with the transactions or series of transactions pursuant to which such Person became a Restricted Subsidiary;
- (7) Liens in favor of the Company or any Restricted Subsidiary;
- (8) Liens arising from the rendering of a final judgment or order against the Company or any Restricted Subsidiary that does not give rise to an Event of Default;
- (9) Liens securing reimbursement obligations with respect to letters of credit that encumber documents and other property relating to such letters of credit and the products and proceeds thereof;
- (10) Liens encumbering customary initial deposits and margin deposits, and other Liens that are within the general parameters customary in the industry and incurred in the ordinary course of business, in each case, securing Indebtedness under Hedging Obligations permitted by clause (f) of the second paragraph of the covenant under the caption “— Limitation on Indebtedness and Preferred Stock”;

- (11) Liens existing on the Original Issue Date;
- (12) Liens securing Indebtedness which is Incurred to refinance secured Indebtedness which is permitted to be Incurred under clause (e) of the second paragraph of the covenant described under the caption entitled “— Limitation on Indebtedness and Preferred Stock”; *provided* that such Liens do not extend to or cover any property or assets of the Company or any Restricted Subsidiary other than the property or assets securing the Indebtedness being refinanced;
- (13) Liens under the Security Documents;
- (14) Liens securing any Permitted Pari Passu Secured Indebtedness that complies with each of the requirements set forth under “— Security — Permitted Pari Passu Secured Indebtedness”;
- (15) any interest or title of a lessor in the property subject to any operating lease;
- (16) Liens securing Indebtedness of the Company or any Restricted Subsidiary under any Pre-Registration Mortgage Guarantee which is permitted to be Incurred under clause (g) of the second paragraph of the covenant under the caption “— Limitation on Indebtedness and Preferred Stock”;
- (17) easements, rights-of-way, municipal and zoning ordinances or other restrictions as to the use of properties in favor of governmental agencies or utility companies that do not materially adversely affect the value of such properties or materially impair the use for the purposes of which such properties are held by the Company or any Restricted Subsidiary;
- (18) Liens (including extensions and renewals thereof) upon real or personal property acquired after the Original Issue Date; *provided* that, (a) such Lien is created solely for the purpose of securing Indebtedness of the type described under clause (2)(h) of the covenant under the caption entitled “— Certain Covenants — Limitation on Indebtedness and Preferred Stock” and such Lien is created prior to, at the time of or within 180 days after the later of the acquisition or the completion of development, construction or improvement of such property, (b) the principal amount of the Indebtedness secured by such Lien does not exceed 100% of the cost of such property, development, construction or improvement and (c) such Lien shall not extend to or cover any property or assets other than such item of property and any improvements on such item; *provided* that, in the case of clauses (b) and (c), such Lien may cover other property or assets (instead of or in addition to such item of property or improvements) and the principal amount of Indebtedness secured by such Lien may exceed 100% of such cost if (x) such Lien is incurred in the ordinary course of business and (y) the aggregate book value of property or assets (as reflected in the most recent available consolidated financial statements of the Company (which may be internal consolidated statements) or, if any such property or assets have been acquired since the date of such financial statements, the cost of such property or assets) subject to Liens incurred pursuant to this clause (18) does not exceed 130% of the aggregate principal amount of Indebtedness secured by such Liens;
- (19) Liens on deposits of pre-sale proceeds made in order to secure the completion and delivery of pre-sold properties and issuance of the related land use title made in the ordinary course of business and not securing Indebtedness of the Company or any Restricted Subsidiary;
- (20) Liens on deposits made in order to comply with statutory obligations to maintain deposits for workers compensation claims and other purposes specified by statute made in the ordinary course of business and not securing Indebtedness of the Company or any Restricted Subsidiary;
- (21) Liens on deposits made in order to secure the performance of the Company or any of its Restricted Subsidiaries in connection with the acquisition of real property or land use rights by

the Company or any of its Restricted Subsidiaries in the ordinary course of business and not securing Indebtedness of the Company or any Restricted Subsidiary;

- (22) Liens granted by the Company or a PRC Restricted Subsidiary in favor of an Insurance Company Investor to secure the obligations of a Subsidiary of such PRC Restricted Subsidiary in which such Insurance Company Investor holds or acquires a minority equity interest to pay a guaranteed or preferred return to such Insurance Company Investor; and
- (23) Liens Incurred on deposits made to secure Bank Deposit Secured Indebtedness of the type described under paragraph (r) of the second paragraph of the “— Certain Covenants — Limitation on Indebtedness” covenant;

*provided* that, with respect to the Collateral, “Permitted Liens” shall only refer to the Liens described in clauses (1), (6), (13) and (14) of this definition.

“Permitted Pari Passu Secured Indebtedness” has the meaning set forth under “— Security — Permitted Pari Passu Secured Indebtedness.”

“Permitted Subsidiary Indebtedness” means Indebtedness of, and all Preferred Stock issued by, the Restricted Subsidiaries, taken as a whole; *provided* that, on the date of the Incurrence of such Indebtedness and after giving effect thereto and the application of the proceeds thereof, the aggregate principal amount outstanding of all such Indebtedness (excluding Public Indebtedness and any Indebtedness of any Restricted Subsidiary permitted under clauses 2(a), (b), (d), (f) and (g) of the covenant described under “— Certain Covenants — Limitation on Indebtedness and Preferred Stock”) does not exceed an amount equal to 15% of the Total Assets.

“Person” means any individual, corporation, partnership, limited liability company, joint venture, trust, unincorporated organization or government or any agency or political subdivision thereof.

“Pre-Registration Mortgage Guarantee” means any Indebtedness of the Company or any Restricted Subsidiary consisting of a guarantee in favor of any bank or other similar financial institutions in the ordinary course of business of secured loans of purchasers of individual units of properties from the Company or any Restricted Subsidiary; *provided* that, any such guarantee shall be released in full on or before the perfection of a security interest in such properties under applicable law in favor of the relevant lender.

“Preferred Stock” as applied to the Capital Stock of any Person means Capital Stock of any class or classes that by its term is preferred as to the payment of dividends, or as to the distribution of assets upon any voluntary or involuntary liquidation or dissolution of such Person, over shares of Capital Stock of any other class of such Person.

“PRC CJV” means any Subsidiary that is a Sino-foreign cooperative joint venture enterprise with limited liability, established in the PRC pursuant to the Law of the People’s Republic of China on Sino-foreign Cooperative Joint Ventures adopted on April 13, 1988 (as most recently amended on October 13, 2000) and the Detailed Rules for the Implementation of the Law of the People’s Republic of China on Sino-foreign Cooperative Joint Ventures promulgated on September 4, 1995, as such laws may be amended.

“PRC CJV Partner” means with respect to a PRC CJV, the other party to the joint venture agreement relating to such PRC CJV with the Company or any Restricted Subsidiary.

“PRC Restricted Subsidiary” means a Restricted Subsidiary organized under the laws of the PRC.

“Public Indebtedness” means any bonds, debentures, notes or similar debt securities issued in a public offering or a private placement (other than the Notes) to institutional investors.

“Qualified Exchange” means either (1) The New York Stock Exchange, the London Stock Exchange, The Stock Exchange of Hong Kong Limited, the Nasdaq Stock market or Singapore Exchange Securities

Trading Limited or (2) a national securities exchange (as such term is defined in Section 6 of the U.S. Exchange Act) or a designated offshore securities market (as such term is defined in Rule 902(b) under the U.S. Securities Act).

“Qualified IPO” means an initial public offering, and a listing, of ordinary shares of a company on a Qualified Exchange; *provided* that in the case that such listing is on a national securities exchange (as such term is defined in Section 6 of the U.S. Exchange Act) or a designated offshore securities market (as such term is defined in Rule 902(b) under the U.S. Securities Act), such listing shall result in a public float of no less than the percentage required by the applicable listing rules.

“Rate Calculation Business Day” means a day (other than a Saturday, Sunday or public holiday) on which commercial banks are open for general business (including dealings in foreign exchange) in Hong Kong or The City of New York.

“Rate Calculation Date” means the day which is two Rate Calculation Business Days before the due date of the relevant amount.

“Rating Agencies” means (1) S&P and (2) Moody’s and (3) if S&P or Moody’s or both shall not make a rating of the Notes publicly available, a nationally recognized securities rating agency or agencies, as the case may be, selected by the Company, which shall be substituted for S&P or Moody’s or both, as the case may be.

“Rating Category” means (1) with respect to S&P, any of the following categories: “BB,” “B,” “CCC,” “CC,” “C” and “D” (or equivalent successor categories); (2) with respect to Moody’s, any of the following categories: “Ba,” “B,” “Caa,” “Ca,” “C” and “D” (or equivalent successor categories); and (3) the equivalent of any such category of S&P or Moody’s used by another Rating Agency. In determining whether the rating of the Notes has decreased by one or more gradations, gradations within Rating Categories (“+” and “-” for S&P; “1,” “2” and “3” for Moody’s; or the equivalent gradations for another Rating Agency) shall be taken into account (e.g., with respect to S&P, a decline in a rating from “BB+” to “BB,” as well as from “B-” to “B+”, will constitute a decrease of one gradation).

“Rating Date” means (1) in connection with a Change of Control Triggering Event, that date which is 90 days prior to the earlier of (x) a Change of Control and (y) a public notice of the occurrence of a Change of Control or of the intention by the Company or any other Person or Persons to effect a Change of Control or (2) in connection with actions contemplated under the caption “— Consolidation, Merger and Sale of Assets”, that date which is 90 days prior to the earlier of (x) the occurrence of any such actions as set forth therein and (y) a public notice of the occurrence of any such actions.

“Rating Decline” means (1) in connection with a Change of Control Triggering Event, the occurrence on, or within six months after, the date, or public notice of the occurrence of, a Change of Control or the intention by the Company or any other Person or Persons to effect a Change of Control (which period shall be extended so long as the rating of the Notes is under publicly announced consideration for possible downgrade by any of the Rating Agencies) of any of the events listed below, or (2) in connection with actions contemplated under the caption “— Consolidation, Merger and Sale of Assets”, the notification by any of the Rating Agencies that such proposed actions will result in any of the events listed below:

- (a) in the event the Notes are rated by both Moody’s and S&P on the Rating Date as Investment Grade, the rating of the Notes by either Rating Agency shall be below Investment Grade;
- (b) in the event the Notes are rated by either, but not both, of the Rating Agencies on the Rating Date as Investment Grade, the rating of the Notes by such Rating Agency shall be below Investment Grade; or
- (c) in the event the Notes are rated below Investment Grade by both Rating Agencies on the Rating Date, the rating of the Notes by either Rating Agency shall be decreased by one or more gradations (including gradations within Rating Categories as well as between Rating Categories).

“Renminbi,” “RMB” or “CNY” means the lawful currency of the People’s Republic of China, excluding Hong Kong, Macau and Taiwan for the purposes of the Indenture.

“Replacement Assets” means, on any date, property or assets (other than current assets) of a nature or type or that are used in a Permitted Business.

“Restricted Subsidiary” means any Subsidiary of the Company other than an Unrestricted Subsidiary.

“S&P” means Standard & Poor’s Ratings Services and its affiliates.

“Sale and Leaseback Transaction” means any direct or indirect arrangement relating to property (whether real, personal or mixed), now owned or hereafter acquired whereby the Company or any Restricted Subsidiary transfers such property to another Person and the Company or any Restricted Subsidiary leases it from such Person. Notwithstanding the foregoing, “Sale and Leaseback Transaction” shall not include the sale or transfer of real property to another Person that is leased by the Company or any Restricted Subsidiary pursuant to an Ordinary Course Operating Lease.

“Secured Parties” means, collectively, (i) the trustee for the 2010 Notes (for itself and for the benefit of the holders of 2010 Notes); (ii) the trustee for the 2012 Notes (for itself and for the benefit of the holders of 2012 Notes); (iii) the trustee for the January 2013 Notes (for itself and for the benefit of the holders of January 2013 Notes); (iv) the Trustee (for itself and for the benefit of the holders of the Notes); and (v) (x) the holder of any other Permitted Pari Passu Secured Indebtedness (if there is only one creditor with respect to any series of Permitted Pari Passu Secured Indebtedness) or (y) the representative or agent of the holders of any Permitted Pari Passu Secured Indebtedness (if there is more than one such creditor), in each case that has become a party to the Intercreditor Agreement on behalf of itself, or as the case may be, holder(s) of Permitted Pari Passu Secured Indebtedness.

“Secured Parties Representatives” means, collectively, the Trustee, the trustee for the 2010 Notes, the trustee for the 2012 Notes, the trustee for the January 2013 Notes and the holders (or their representatives or agents) of any Permitted Pari Passu Secured Indebtedness, in each case that are parties to the Intercreditor Agreement or other similar agreements pursuant to the terms of the Indenture, if any.

“Security Documents” means, collectively, the pledge agreements and any other agreements or instruments that may evidence or create any security interest in favor of the Trustee and/or any Holders in any or all of the Collateral.

“Senior Indebtedness” of the Company or a Restricted Subsidiary, as the case may be, means all Indebtedness of the Company or the Restricted Subsidiary, as relevant, whether outstanding on the Original Issue Date or thereafter created, except for Indebtedness which, in the instrument creating or evidencing the same, is expressly stated to be subordinated in right of payment to (a) in respect of the Company, the Notes, (b) in respect of any Restricted Subsidiary that is a Subsidiary Guarantor, its Subsidiary Guarantee, or (c) in respect of any Restricted Subsidiary that is a JV Subsidiary Guarantor, its JV Subsidiary Guarantee; *provided* that Senior Indebtedness does not include (1) any obligation to the Company or any Restricted Subsidiary, (2) trade payables or (3) Indebtedness Incurred in violation of the Indenture.

“Spot Rate,” for a Rate Calculation Date, means the RMB/U.S. Dollar official fixing rate, expressed as the amount of RMB per one U.S. Dollar, for settlement in two Rate Calculation Business Days reported by the Treasury Markets Association which appears on Reuters page <CNHFIX> at approximately 11:15 a.m. (Hong Kong time). If such rate is not available, the Paying Agent will determine the Spot Rate at or around 11.00 a.m. (Hong Kong time) on the Rate Calculation Date as the most recently available RMB/U.S. dollar official fixing rate for settlement in two Rate Calculation Business Days reported by The State Administration of Foreign Exchange of the PRC, which is reported on the Reuters Screen Page CNY=SAEC. Reference to a page on the Reuters Screen means the display page so designated on the Reuter Monitor Money Rates Service (or any successor service) or such other page as may replace that page for the purpose of displaying a comparable currency exchange rate.

“Staged Acquisition Agreement” means an agreement between the Company or a Restricted Subsidiary and an Independent Third Party (x) pursuant to which the Company or such Restricted



Subsidiary agrees to acquire not less than a majority of the Capital Stock of a Person for consideration that is not more than the appraised value of such Capital Stock of such Person (determined by an independent appraisal firm, accountancy firm or investment bank of recognized international standing appointed by the Company) at the time the Company or such Restricted Subsidiary enters into such Agreement and (y) which provides that the payment of the purchase price for such Capital Stock is made in more than one installment over a period of time.

“Stated Maturity” means, (1) with respect to any Indebtedness, the date specified in such debt security as the fixed date on which the final installment of principal of such Indebtedness is due and payable as set forth in the documentation governing such Indebtedness and (2) with respect to any scheduled installment of principal of or interest on any Indebtedness, the date specified as the fixed date on which such installment is due and payable as set forth in the documentation governing such Indebtedness.

“Subordinated Indebtedness” means any Indebtedness of the Company, any Subsidiary Guarantor or any JV Subsidiary Guarantor which is contractually subordinated or junior in right of payment to the Notes, any Subsidiary Guarantee or any JV Subsidiary Guarantee, as applicable, pursuant to a written agreement to such effect.

“Subsidiary” means, with respect to any Person, any corporation, association or other business entity of which more than 50% of the voting power of the outstanding Voting Stock is owned, directly or indirectly, by such Person and one or more other Subsidiaries of such Person.

“Subsidiary Guarantee” means any Guarantee of the obligations of the Company under the Indenture and the Notes by any Subsidiary Guarantor.

“Subsidiary Guarantor” means any initial Subsidiary Guarantor named herein and any other Restricted Subsidiary which guarantees the payment of the Notes pursuant to the Indenture and the Notes; *provided* that Subsidiary Guarantor will not include (a) any Person whose Subsidiary Guarantee has been released in accordance with the Indenture and the Notes or (b) any JV Subsidiary Guarantor.

“Subsidiary Guarantor Pledgor” means any initial Subsidiary Guarantor Pledgor named herein and any other Subsidiary Guarantor which pledges Collateral to secure the obligations of the Company under the Notes and the Indenture and of such Subsidiary Guarantor under its Subsidiary Guarantee; *provided* that a Subsidiary Guarantor Pledgor will not include any person whose pledge under the Security Documents has been released in accordance with the Security Documents, the Indenture and the Notes.

“Temporary Cash Investment” means any of the following:

- (1) direct obligations of the United States of America, any state of the European Economic Area, the People’s Republic of China and Hong Kong or any agency of any of the foregoing or obligations fully and unconditionally Guaranteed by the United States of America, any state of the European Economic Area, the People’s Republic of China and Hong Kong or any agency of any of the foregoing, in each case maturing within one year, which in the case of obligations of, or obligations Guaranteed by, any state of the European Economic Area, shall be rated at least “A” by S&P or Moody’s;
- (2) time deposit accounts, certificates of deposit and money market deposits maturing within 180 days of the date of acquisition thereof issued by a bank or trust company which is organized under the laws of the United States of America, any state thereof, any state of the European Economic Area or Hong Kong, and which bank or trust company has capital, surplus and undivided profits aggregating in excess of US\$100 million (or the Dollar Equivalent thereof) and has outstanding debt which is rated “A” (or such similar equivalent rating) or higher by at least one nationally recognized statistical rating organization (as defined in Rule 436 under the U.S. Securities Act) or any money market fund sponsored by a registered broker dealer or mutual fund distributor;
- (3) repurchase obligations with a term of not more than 30 days for underlying securities of the types described in clause (1) above entered into with a bank or trust company meeting the qualifications described in clause (2) above;

- (4) commercial paper, maturing not more than 180 days after the date of acquisition thereof, issued by a corporation (other than an Affiliate of the Company) organized and in existence under the laws of the United States of America, any state thereof or any foreign country recognized by the United States of America with a rating at the time as of which any investment therein is made of “P-1” (or higher) according to Moody’s or “A-1” (or higher) according to S&P;
- (5) securities, maturing within one year of the date of acquisition thereof, issued or fully and unconditionally Guaranteed by any state, commonwealth or territory of the United States of America, or by any political subdivision or taxing authority thereof, and rated at least “A” by S&P or Moody’s;
- (6) any money market fund that has at least 95% of its assets continuously invested in investments of the types described in clauses (1) through (5) above; and
- (7) time deposit accounts, certificates of deposit, overnight or call deposits and money market deposits with Bank of China, Bank of Communications, China Agricultural Bank, China Everbright Bank, China Construction Bank, China Merchants Bank, Huaxia Bank, Shanghai Pudong Development Bank, Industrial Bank Co., Ltd., Nanyang Commercial Bank, Ltd., China Minsheng Banking Corp., Ltd., Shenzhen Ping An Bank, Hongkong and Shanghai Banking Corporation, Shenzhen Development Bank, Guangdong Development Bank, Bank of Chengdu, Hua Xia Bank Co., Ltd., Shanghai Pudong Development Bank Co., Ltd. and Industrial Bank Co., Ltd., (ii) any other bank, trust company or other financial institution organized under the laws of the PRC or Hong Kong whose long-term debt is rated as high or higher than any of those banks described in clause (i) of this paragraph or (iii) any other bank, trust company or other financial institution organized under the laws of the PRC or Hong Kong; *provided* that, in the case of clause (iii), such deposits do not exceed US\$10.0 million (or the Dollar Equivalent thereof) with any single bank or US\$30.0 million (or the Dollar Equivalent thereof) in the aggregate, at any date of determination thereafter.

“Total Assets” means, as of any date, the total consolidated assets of the Company and its Restricted Subsidiaries measured in accordance with GAAP as of the last day of the most recent semi-annual period for which consolidated financial statements of the Company (which the Company shall use its best efforts to compile on a timely manner) are available (which may be internal consolidated financial statements); *provided* that only with respect to clause (2)(h) of “— Certain Covenants — Limitation on Indebtedness and Preferred Stock” covenant and the definition of “Permitted Subsidiary Indebtedness,” Total Assets shall be calculated after giving pro forma effect to include the cumulative value of all of the real or personal property or equipment the acquisition, development, construction or improvement of which requires or required the Incurrence of Indebtedness and calculation of Total Assets thereunder, as measured by the purchase price or cost therefor or budgeted cost provided in good faith by the Company or any of its Restricted Subsidiaries to the bank or other similar financial institutional lender providing such Indebtedness, *provided further* that only with respect to the calculation of “Non-Guaranteed Portion,” in the case of a JV Subsidiary Guarantor executing a JV Subsidiary Guarantee and any other Restricted Subsidiary of the Company that became a JV Subsidiary Guarantor after the end of the most recently ended semi-annual or annual period, the amount of Total Assets shall be calculated after giving pro forma effect to the sale or issuance of Capital Stock to the relevant Independent Third Parties.

“Trade Payables” means, with respect to any Person, any accounts payable or any other indebtedness or monetary obligation to trade creditors created, assumed or Guaranteed by such Person or any of its Subsidiaries arising in the ordinary course of business in connection with the acquisition of goods or services.

“Transaction Date” means, with respect to the Incurrence of any Indebtedness, the date such Indebtedness is to be Incurred and, with respect to any Restricted Payment, the date such Restricted Payment is to be made.

“Unrestricted Subsidiary” means (1) any Subsidiary of the Company that at the time of determination shall be designated an Unrestricted Subsidiary by the Board of Directors in the manner provided in the Indenture; and (2) any Subsidiary of an Unrestricted Subsidiary. On the Original Issue Date, the Unrestricted Subsidiaries include Fantasia (Taiwan) Development Co., Ltd. (台灣花樣年開發股份有限公司), Fantasia Senior Housing Management Holdings Group Co., Limited, Fantasia Senior Housing Management Group Co., Limited, Fantasia Senior Housing Management Group (HK) Co., Limited, Fantasia Cultural Tourism Management Holdings Group Co., Limited, Fantasia Cultural Tourism Management Group Co., Limited, Fantasia Cultural Tourism Management Group (HK) Co., Limited, Fantasia Commercial Management Holdings Group Co., Limited, Fantasia Commercial Management Group Co., Limited, Fantasia Commercial Management Group (HK) Co., Limited, Fantasia Hotel Management Holdings Group Co., Limited, Fantasia Hotel Management Group Co., Limited (previously known as Precise Idea Limited), Fantasia Hotel Management Group (HK) Co., Limited (previously known as Fantasia Hotel Management (International) Company Limited), Colour Cloud Holdings Group Co., Limited, Colour Cloud Group Co., Limited, Colour Cloud Group (HK) Co., Limited, Colour Pay Treasure Holdings Group Co., Limited, Colour Pay Group Co., Limited, Colour Pay Group (HK) Co., Limited, Cai Hua Holdings Limited, Trade Dragon Holdings Limited, Tokyo Fantasia Investment Co., Ltd., Fantasia Investment (Singapore) Pte. Ltd., Tong Yuan Holdings Limited, Novel Era Holdings Limited, Treasure Isle Holdings Limited, Zhao Xing Holdings Limited, Colour Life Services Group Co., Limited, Ace Link Pacific Limited, Colour Life Services Group (HK) Co., Limited, Yahao Technology Development (Shenzhen) Company Limited, Shenzhen Colour Life Services Group Co., Limited, Fantasia Culture Tourism Management Group, Fantasia (Novena) Pte. Ltd., Nanjing Mingcheng Property Management Company Limited, Heyuan Huada Property Management Company Limited, Shenzhen Xingyanhang Property Company Limited, Tieling Zhengnan Property Management Company Limited, Shenzhen Colour Life Property Management Company Limited, Huizhou Youlin Property Management Company Limited, Shenyang Auspicious Baxter Property Services Company Limited, Tianjin Xintang Property Management Company Limited, Shenzhen Hui Gang Property Management Company Limited, Shenzhen Colour Life Network Services Company Limited, Shenzhen Kaiyuan Tongji Building Science & Technology Company Limited, Shenzhen Ancaihua Energy Investment Company Limited, Shenzhen Caiyue Hotel Management Company Limited, Shenzhen Caiyue Hotel Company Limited, Shenzhen Robert Housekeeper Property Management Company Limited, Shenzhen Colour Life Rainbow Clean Service Company Limited, Shanxi Liantang Property Services Company Limited, Qinhuangdao Hongtianyuan Property Company Limited, Shaanxi Colour Life Community Services Company Limited, Pingdingshan Longkang Property Services Company Limited, Nanjing Huitao Property Management Services Company Limited, Shenzhen Huawanli Commercial Management Limited, Shenzhen Fantasia Commercial Management Company Limited, Shenzhen Fantasia Culture and Tourism Management Company Limited, Chengdu Fantasia Wangcong Culture Development Company Limited, Shenzhen Fantasia Health Endowment Management Company Limited, Shenzhen Futainian Investment Management Company Limited, Shenzhen Huawanli Hotel Management Company Limited, Shenzhen Fantasia Hotel Management Company Limited, Chengdu Fantasia Quyuan Hotel Management Company Limited, Yixing Town on Water Hotel Management Company Limited, Pujiang Grande Valley Hotel Management Company Limited, Shenzhen Colour Life Community Technology Services Company Limited, Shenzhen Qianhai Colour Cloud Network Technology Company Limited, Colour Pay Treasure Holdings Group Co., Limited and Shenzhen Qianhai Colour Pay Network Technology Company Limited.

“Voting Stock” means, with respect to any Person, Capital Stock of any class or kind ordinarily having the power to vote for the election of directors, managers or other voting members of the governing body of such Person.

“Wholly Owned” means, with respect to any Subsidiary of any Person, the ownership of all of the outstanding Capital Stock of such Subsidiary (other than any director’s qualifying shares or Investments by foreign nationals mandated by applicable law) by such Person or one or more Wholly Owned Subsidiaries of such Person; *provided* that Subsidiaries that are PRC CJVs shall not be considered Wholly Owned Subsidiaries.

## TAXATION

The following summary of certain Cayman Islands, Hong Kong and PRC tax consequences of the purchase, ownership and disposition of Notes is based upon applicable laws, regulations, rulings and decisions in effect as of the date of this offering memorandum, all of which are subject to change (possibly with retroactive effect). This discussion does not purport to be a comprehensive description of all the tax considerations that may be relevant to a decision to purchase, own or dispose of the Notes and does not purport to deal with consequences applicable to all categories of investors, some of which may be subject to special rules. Persons considering the purchase of Notes should consult their own tax advisors concerning the tax consequences of the purchase, ownership and disposition of Notes, including such possible consequences under the laws of their country of citizenship, residence or domicile.

### *Cayman Islands*

The following is a discussion on certain Cayman Islands income tax consequences of an investment in the Notes. The discussion is a general summary of present law, which is subject to prospective and retroactive change. It is not intended as tax advice, does not consider any investor's particular circumstances, and does not consider tax consequences other than those arising under Cayman Islands law.

Under the laws of the Cayman Islands, payments of interest and principal on the Notes will not be subject to taxation and no withholding will be required on the payment of interest and principal or premium to any holder of the Notes, as the case may be, nor will gains derived from the disposal of the Notes be subject to Cayman Islands income or corporation tax. The Cayman Islands currently have no income, corporation or capital gains tax and no estate duty, inheritance tax or gift tax. The Cayman Islands are not party to any double taxation treaties.

No stamp duty is payable in respect of the issue of the Notes. An instrument of transfer in respect of a Note is stampable if executed in or brought into the Cayman Islands.

The Company has been incorporated under the laws of the Cayman Islands as an exempted company with limited liability and, as such, has obtained an undertaking from the Governor in Cabinet of the Cayman Islands as to tax concessions under the Tax Concessions Law (1999 Revision). In accordance with the provision of section 6 of The Tax Concessions Law (1999 Revision), the Governor in Cabinet undertakes with the Company:

- That no law which is hereafter enacted in the Cayman Islands imposing any tax to be levied on profits, income, gains or appreciations shall apply to the Company or its operations; and
- In addition, that no tax to be levied on profits, income, gains or appreciations or which is in the nature of estate duty or inheritance tax shall be payable, on or in respect of the shares, debentures or other obligations of the Company, or by way of the withholding, in whole or part, of any relevant payment as defined in Section 6(3) of the Tax Concessions Law (1999 Revision).
- These concessions shall be for a period of 20 years from October 30, 2007.

### *Hong Kong*

Withholding Tax. No withholding tax in Hong Kong is payable on payments of principal (including any premium payable on redemption of the Notes) or interest in respect of the Notes.

Profits Tax. Hong Kong profits tax is charged on every person carrying on a trade, profession or business in Hong Kong in respect of assessable profits arising in or derived from Hong Kong from such trade, profession or business. Under the Inland Revenue Ordinance (Chapter 112 of the Laws of Hong Kong) (the “Inland Revenue Ordinance”), as it is currently applied, Hong Kong profits tax may be charged on revenue profits arising on the sale, disposal or redemption of the Notes where such sale, disposal or redemption is or forms part of a trade, profession or business carried on in Hong Kong.

Interest on the Notes will be subject to Hong Kong profits tax where such interest has a Hong Kong source, and is received by or accrues to:

- a financial institution (as defined in the Inland Revenue Ordinance) and arises through or from the carrying on by the financial institution of its business in Hong Kong; or
- a corporation carrying on a trade, profession or business in Hong Kong; or
- a person, other than a corporation, carrying on a trade, profession or business in Hong Kong and such interest is in respect of the funds of the trade, profession or business.

Although no tax is imposed in Hong Kong in respect of capital gains, Hong Kong profits tax may be chargeable on trading gains arising on the sale or disposal of the Notes where such transactions are or form part of a trade, profession or business carried on in Hong Kong.

Stamp Duty. No Hong Kong stamp duty will be chargeable upon the issue or transfer (for so long as the register of holders of the Notes is maintained outside Hong Kong) of a Note.

### ***PRC Taxation***

The following summary of certain PRC tax consequences of the purchase, ownership and disposition of Notes is based upon applicable laws, rules and regulations in effect as of the date of this offering memorandum, all of which are subject to change (possibly with retroactive effect). This discussion does not purport to be a comprehensive description of all the tax considerations that may be relevant to a decision to purchase, own or dispose of the Notes and does not purport to deal with consequences applicable to all categories of investors, some of which may be subject to special rules. Persons considering the purchase of Notes should consult their own tax advisors concerning the tax consequences of the purchase, ownership and disposition of Notes, including such possible consequences under the laws of their country of citizenship, residence or domicile.

*Taxation on Interest and Capital Gains* Under the PRC EIT Law and implementation regulations issued by the State Council, PRC income tax at the rate of 10% (or lower treaty rate, if any) is withheld from interest payable to investors that are “non-resident enterprises” and that do not have an establishment or place of business in the PRC, or that have such establishment or place of business but the relevant interest income is not effectively connected with the establishment or place of business, to the extent such interest is derived from sources within the PRC. Any gain realized on the transfer of the Notes by such investors is subject to a 10% (or lower treaty rate, if any) PRC income tax if such gain is regarded as income of a “non-resident enterprise” derived from sources within the PRC. As advised by Commerce & Finance Law Offices, our PRC legal counsel, there is uncertainty as to whether we will be treated as a PRC “resident enterprise” for the purpose of the EIT Law. If we are treated as a PRC “resident enterprise,” the interest we pay in respect of the Notes, and the gain any investor may realize from the transfer of the Notes, may be treated as income derived from sources within the PRC and may be subject to PRC tax. See “Risk Factors — We may be deemed a PRC resident under the EIT Law and be subject to PRC taxation on our worldwide income” and “Interest payable by us to our foreign investors and gain on sale of our Notes may be subject to withholding taxes under PRC tax laws.”

*Stamp duty.* No PRC stamp tax will be chargeable upon the issue or transfer (for so long as the register of holders of the Notes is maintained outside the PRC) of a Note.

## PLAN OF DISTRIBUTION

Merrill Lynch International, Citigroup Global Markets Limited, The Hongkong and Shanghai Banking Corporation Limited and China Merchants Securities (HK) Co., Limited are acting as joint bookrunners and joint lead managers of the offering and as the Initial Purchasers named below. Subject to the terms and conditions stated in the purchase agreement dated the date of this offering memorandum, each Initial Purchaser named below has severally agreed to purchase, and we have agreed to sell to such Initial Purchaser, the principal amount of the Notes set forth opposite such Initial Purchaser's name.

<u>Initial Purchaser</u>	<u>Principal Amount of Notes</u>
Merrill Lynch International . . . . .	CNY300,000,000
Citigroup Global Markets Limited . . . . .	CNY300,000,000
The Hongkong and Shanghai Banking Corporation Limited . . . . .	CNY200,000,000
China Merchants Securities (HK) Co., Limited . . . . .	CNY200,000,000
Total . . . . .	<u>CNY1,000,000,000</u>

The purchase agreement provides that the obligations of the Initial Purchasers to purchase the Notes are subject to approval of legal matters by counsel and to other conditions. The purchase agreement may be terminated by the Initial Purchasers in certain circumstances prior to the delivery and payment of the Notes.

The Initial Purchaser propose to resell the Notes at the offering price set forth on the cover page of this offering memorandum only outside the United States in offshore transactions in reliance on Regulation S under the U.S. Securities Act. See "Transfer Restrictions." The price at which the Notes are offered may be changed at any time without notice. In addition, we have agreed with the Initial Purchasers that we will pay a commission to private banks in connection with the purchase of the Notes by their private bank clients.

We have agreed that, for a period of 30 days from the date of this offering memorandum, we will not, without the prior written consent of the Initial Purchasers, offer, sell, contract to sell, pledge, otherwise dispose of, or enter into any transaction which is designed to, or might reasonably be expected to, result in the disposition by us or any affiliate of us or any person in privity with us or any affiliate of us, directly or indirectly, or announce the offering of, any other debt securities issued or guaranteed by us. The Initial Purchasers in their sole discretion may release any of the securities subject to these lock-up agreements at any time without notice.

The Notes will constitute a new class of securities with no established trading market. Approval in-principle has been received for the listing and quotation of the Notes on the Official List of SGX-ST. However, we cannot assure you that the prices at which the Notes will sell in the market after this offering will not be lower than the initial offering price or that an active trading market for the Notes will develop and continue after this offering. The Initial Purchasers have advised us that they currently intend to make a market in the Notes. However, the Initial Purchasers are not obligated to do so and they may discontinue any market-making activities with respect to the Notes at any time without notice. Accordingly, we cannot assure you as to the liquidity of, or the trading market for, the Notes.

In connection with the offering, the Initial Purchasers may purchase and sell Notes in the open market. Purchases and sales in the open market may include short sales, purchases to cover short positions and stabilizing purchases.

- Short sales involve secondary market sales by the Initial Purchasers of a greater number of Notes than they are required to purchase in the offering.
- Covering transactions involve purchases of Notes in the open market after the distribution has been completed in order to cover short positions.

- Stabilizing transactions involve bids to purchase Notes so long as the stabilizing bids do not exceed a specified maximum.

Purchases to cover short positions and stabilizing purchases, as well as other purchases by the Initial Purchasers for their own accounts, may have the effect of preventing or retarding a decline in the market price of the Notes. They may also cause the price of the Notes to be higher than the price that would otherwise exist in the open market in the absence of these transactions. The Initial Purchasers may conduct these transactions in the over-the-counter market or otherwise. If the Initial Purchasers commence any of these transactions, they may discontinue them at any time.

We expect to deliver the Notes against payment for the Notes on or about the date specified in the last paragraph of the cover page of this offering memorandum, which will be the fifth business day following the date of the pricing of the Notes. As trades in certain secondary markets generally settle in three business days, purchasers who wish to trade Notes on the date of pricing or the next succeeding business day will be required, by virtue of the fact that the Notes initially will settle in T+5, to specify alternative settlement arrangements to prevent a failed settlement. Purchasers of the Notes who wishes to trade the Notes on the date of pricing or the next succeeding business day should consult their own advisor.

## **Selling Restrictions**

### ***General***

The Initial Purchasers or their respective affiliates have performed commercial banking, investment banking and advisory services for us from time to time for which they have received customary fees and reimbursement of expenses. The Initial Purchasers or their respective affiliates may, from time to time, engage in transactions with and perform services for us in the ordinary course of their businesses for which they may receive customary fees and reimbursement of expenses. We may enter into hedging or other derivative transactions as part of our risk management strategy with one or more of the Initial Purchasers, which may include transactions relating to our obligations under the Notes. Our obligations under these transactions may be secured by cash or other collateral.

The Initial Purchasers or their respective affiliates may purchase the Notes for its or their own account and enter into transactions, including credit derivatives, such as asset swaps, repackaging and credit default swaps relating to the Notes and/or other securities of ours or of our subsidiaries or affiliates at the same time as the offer and sale of the Notes or in secondary market transactions. Such transactions would be carried out as bilateral trades with selected counterparties and separately from any existing sale or resale of Notes to which this offering memorandum relates (notwithstanding that such selected counterparties may also be purchasers of Notes).

We and the Subsidiary Guarantors have agreed to indemnify the Initial Purchasers against certain liabilities, including liabilities under the U.S. Securities Act, or to contribute to payments that the initial purchasers may be required to make because of any of those liabilities.

No action has been taken or will be taken in any country or jurisdiction that would permit a public offering of the Notes, or the possession, circulation or distribution of this offering memorandum or any other material relating to the Notes, in any jurisdiction where action for any such purpose may be required. Accordingly, the Notes may not be offered or sold, directly or indirectly, and neither this offering memorandum nor such other material may be distributed or published, in or from any country or jurisdiction except in compliance with any applicable rules and regulations of such country or jurisdiction.

### ***United States***

The Notes, the Subsidiary Guarantees and the JV Subsidiary Guarantee (if any) have not been and will not be registered under the U.S. Securities Act or any state securities laws and may not be offered or sold within the United States and may only be offered or sold outside the United States in compliance with Regulation S under the U.S. Securities Act. See “Transfer Restrictions.”

In addition, until 40 days after the commencement of this offering, an offer or sale of Notes within the United States by a dealer (whether or not participating in this offering) may violate the registration requirements of the U.S. Securities Act.

### ***United Kingdom***

No invitation or inducement to engage in investment activity (within the meanings of section 21 of the Financial Services and Markets Act 2000 (the “FSMA”) received by the Initial Purchasers in connection with the issue or sale of the Notes may be communicated or caused to be communicated except in circumstances in which section 21(1) of the FSMA does not apply to the Company. All applicable provisions of the FSMA must be complied with respect to anything done or to be done by the Initial Purchasers in relation to any Notes in, from or otherwise involving the United Kingdom.

### ***Hong Kong***

The Notes will not be offered or sold in Hong Kong, by means of any document, other than (i) to “professional investors” as defined in the Securities and Futures Ordinance (Cap. 571 of the Laws of Hong Kong) (the “SFO”) and any rules made thereunder; or (ii) in other circumstances which do not result in any such document being a “prospectus” as defined in the Companies Ordinance (Cap. 32 of the Laws of Hong Kong) or which do not constitute an offer to the public within the meaning of that Ordinance. No advertisement, invitation or document relating to the Notes may be issued or may be in the possession of any person for the purpose of being issued, whether in Hong Kong or elsewhere, which is directed at, or the contents of which are likely to be accessed or read by, the public in Hong Kong (except if permitted to do so under the laws of Hong Kong) other than with respect to the Notes which are or are intended to be disposed of only to persons outside Hong Kong or only to “professional investors” as defined in the SFO and any rules made thereunder.

### ***Japan***

The Notes have not been and will not be registered under the Financial Instruments and Exchange Law of Japan (Law No. 25 of 1948) (as amended) (the “FIEL”), and disclosure under the FIEL has not been made with respect to the Notes. Accordingly, the Notes may not be offered or sold, directly or indirectly in Japan or to, or for the account of, any resident of Japan, or to others for reoffering or re-sale, directly or indirectly in Japan or to, or for the benefit of, any resident of Japan, except pursuant to any exemption from the registration requirements of the FIEL and otherwise in compliance with the FIEL and other applicable provisions of Japanese laws and regulations. As used in this paragraph, “resident of Japan” means any person residing in Japan, including any corporation or other entity organized under the laws of Japan.

### ***Singapore***

This offering memorandum has not been and will not be registered as a prospectus with the Monetary Authority of Singapore (the “MAS”). Accordingly, this offering memorandum and any other document or material in connection with the offer or sale, or invitation for subscription or purchase, of the Notes may not be circulated or distributed, nor may the Notes be offered or sold, or be made the subject of an invitation for subscription or purchase, whether directly or indirectly, to persons in Singapore other than (i) to an institutional investor under Section 274 of the Securities and Futures Act, Chapter 289 of Singapore (the “SFA”), (ii) to a relevant person pursuant to Section 275(1), or any person pursuant to Section 275(1A), and in accordance with the conditions specified in Section 275, of the SFA or (iii) otherwise pursuant to, and in accordance with the conditions of, any other applicable provision of the SFA.



Where the Notes are subscribed or purchased in reliance of an exemption under Sections 274 or 275 of the SFA, the Notes shall not be sold within the period of six months from the date of the initial acquisition of the Notes, except to any of the following persons:

- (a) an institutional investor (as defined in Section 4A of the SFA);
- (b) a relevant person (as defined in Section 275(2) of the SFA); or
- (c) any person pursuant to an offer referred to in Section 275(1A) of the SFA;

unless expressly specified otherwise in Section 276(7) of the SFA or Regulation 32 of the Securities and Futures (Offers of Investments) (Shares and Debentures) Regulations 2005 of Singapore (“SFR”).

Where the Notes are subscribed or purchased under Section 275 of the SFA by a relevant person which is:

- (a) a corporation (which is not an accredited investor (as defined in Section 4A of the SFA)) the sole business of which is to hold investments and the entire share capital of which is owned by one or more individuals, each of whom is an accredited investor; or
- (b) a trust (where the trustee is not an accredited investor) whose sole purpose is to hold investments and each beneficiary of the trust is an individual who is an accredited investor,

securities (as defined in Section 239(1) of the SFA) of that corporation or the beneficiaries’ rights and interest (howsoever described) in that trust shall not be transferred within six months after that corporation or that trust has acquired the Notes pursuant to an offer made under Section 275 of the SFA except:

- (1) to an institutional investor (as defined in Section 4A of the SFA), or to a relevant person (as defined in Section 275(2) of the SFA) and in accordance with the conditions specified in Section 275 of the SFA;
- (2) (in the case of such corporation) where the transfer arises from an offer referred to in Section 276(3)(i)(B) of the SFA or (in the case of such trust) where the transfer arises from an offer referred to in Section 276(4)(i)(B) of the SFA;
- (3) where no consideration is or will be given for the transfer;
- (4) where the transfer is by operation of law;
- (5) as specified in Section 276(7) of the SFA; or
- (6) as specified in Regulation 32 of the SFR.

### ***PRC***

This offering memorandum does not constitute a public offer of the Notes, whether by sale or by subscription, in the PRC. The Notes will not be offered or sold within the PRC by means of this offering memorandum or any other document.

### ***Cayman Islands***

No Notes will be offered or sold to the public in the Cayman Islands.

### ***British Virgin Islands***

No invitation will be made directly or indirectly to any person resident in the British Virgin Islands to subscribe for any of the Notes.

## TRANSFER RESTRICTIONS

*Because of the following restrictions, we encourage you to consult legal counsel prior to making any offer, resale, pledge or other transfer of the Notes.*

The Notes are subject to restrictions on transfer as summarized below. By purchasing the Notes, you will be deemed to have made the following acknowledgements, representations to, and agreements with, us and the Initial Purchasers:

1. You understand and acknowledge that:
  - the Notes have not been registered under the U.S. Securities Act or any other applicable securities laws;
  - the Notes are being offered for resale in transactions that do not require registration under the U.S. Securities Act or any other securities laws; and
  - the Notes are being offered and sold only outside the United States in offshore transactions in reliance on Regulation S under the U.S. Securities Act.
2. You represent that you are not an affiliate (as defined in Rule 144 under the U.S. Securities Act) of ours, and you are purchasing the Notes in an offshore transaction in accordance with Regulation S under the U.S. Securities Act.
3. You acknowledge that neither we nor the Initial Purchasers nor any person representing us or the Initial Purchasers have made any representation to you with respect to us or the offering of the Notes, other than the information contained in this offering memorandum. You represent that you are relying only on this offering memorandum in making your investment decision with respect to the Notes. You agree that you have had access to such financial and other information concerning us and the Notes as you have deemed necessary in connection with your decision to purchase the Notes including an opportunity to ask questions of and request information from us.
4. You represent that you are purchasing the Notes for your own account, or for one or more investor accounts for which you are acting as a fiduciary or agent, in each case not with a view to, or for offer or sale in connection with, any distribution of the Notes in violation of the U.S. Securities Act.
5. You acknowledge that we, the Initial Purchasers and others will rely upon the truth and accuracy of the above acknowledgments, representations and agreements. You agree that if any of the acknowledgments, representations or agreements you are deemed to have made by your purchase of the Notes is no longer accurate, you will promptly notify us and the Initial Purchasers. If you are purchasing any Notes as a fiduciary or agent for one or more investor accounts, you represent that you have sole investment discretion with respect to each of those accounts and that you have full power to make the above acknowledgments, representations and agreements on behalf of each account.

6. You also acknowledge that this offering memorandum has not been registered as a prospectus with the MAS. Accordingly, you have represented, warranted and agreed that you have not offered or sold any Notes or caused the Notes to be made the subject of an invitation for subscription or purchase and will not offer or sell any Notes or cause the Notes to be made the subject of an invitation for subscription or purchase, and have not circulated or distributed, nor will you circulate or distribute, this offering memorandum or any other document or material in connection with the offer or sale, or invitation for subscription or purchase, of the Notes, whether directly or indirectly, to persons in Singapore other than (i) to an institutional investor under Section 274 of the SFA, (ii) to a relevant person pursuant to Section 275(1), or any person pursuant to Section 275(1A), and in accordance with the conditions specified in Section 275, of the SFA or (iii) otherwise pursuant to, and in accordance with the conditions of, any other applicable provision of the SFA.

## **RATINGS**

The Notes have been rated B+ by Standard and Poor's Rating Services and B2 by Moody's Investors Service. The ratings reflect the rating agencies' assessment of the likelihood of timely payment of the principal of and interest on the Notes. The ratings do not constitute recommendations to purchase, hold or sell the Notes inasmuch as such ratings do not comment as to market price or suitability for a particular investor. Each such rating should be evaluated independently of any other rating on the Notes, on other securities of ours, or on us. Additionally, we have been assigned a long-term corporate credit rating of BB- with a stable outlook by Standard and Poor's Rating Services and a corporate family rating of B1 with a stable outlook by Moody's Investors Service. We cannot assure you that the ratings will remain in effect for any given period or that the ratings will not be revised by such rating agencies in the future if in their judgment circumstances so warrant.

## **LEGAL MATTERS**

Certain legal matters with respect to the Notes will be passed upon for us by Sidley Austin as to matters of United States federal and New York law and Hong Kong law, Commerce & Finance Law Offices as to matters of PRC law, Conyers Dill & Pearman (Cayman) Limited as to matters of Cayman Islands law and Conyers Dill & Pearman as to matters of British Virgin Islands law.

Certain legal matters will be passed upon for the Initial Purchasers by Davis Polk & Wardwell as to matters of United States federal and New York law and King & Wood Mallesons as to matters of PRC law.

## **INDEPENDENT ACCOUNTANTS**

The consolidated financial statements as of and for the three years ended December 31, 2010, 2011 and 2012 included in this offering memorandum have been audited by Deloitte Touche Tohmatsu, certified public accountants, as stated in their reports appearing herein.

## GENERAL INFORMATION

### Consents

We have obtained all necessary consents, approvals and authorizations in the Cayman Islands, the British Virgin Islands and Hong Kong in connection with the issue and performance of the Notes and the Subsidiary Guarantees. The entering into of the Indenture and the issue of the Notes have been authorized by a resolution of our board of directors dated May 16, 2013.

### Litigation

Except as disclosed in this offering memorandum, there are no legal or arbitration proceedings against or affecting us, any of our subsidiaries or any of our assets, nor are we aware of any pending or threatened proceedings, which are or might be material in the context of this issue of the Notes or the Subsidiary Guarantees.

### No Material Adverse Change

There has been no adverse change, or any development reasonably likely to involve an adverse change, in the condition (financial or otherwise) of our general affairs since December 31, 2012 that is material in the context of the issue of the Notes.

### Documents Available

For so long as any of the Notes is outstanding, copies of the Indenture may be inspected free of charge during normal business hours on any weekday (except public holidays) at the specified offices of the paying agents.

For so long as any of the Notes is outstanding, copies of the accountants' reports and/or our published financial statements, if any, including the accountants' report set out in the section entitled "Index to Consolidated Financial Statements" in this offering memorandum, may be obtained during normal business hours on any weekday (except public holidays) at the specified offices of the paying agents.

### Clearing Systems and Settlement

The Notes will be lodged and cleared through CMU. The CMU instrument number for the Notes is CILHFN13009. For persons seeking to hold a beneficial interest in the Notes through Euroclear or Clearstream, such persons will hold their interests through an account opened and held by Euroclear or Clearstream with the CMU operator. The Hong Kong ISIN and Common Code for the Notes is HK0000150760 and 093560574, respectively.

### Listing of the Notes

Approval in-principle has been received for the listing and quotation of the Notes on the Official List of the SGX-ST. The SGX-ST assumes no responsibility for the correctness of any of the statements made or opinions expressed or reports contained in this offering memorandum. Admission to the Official List of the SGX-ST and quotation of any Notes on the SGX-ST is not to be taken as an indication of the merits of the Company, the Subsidiary Guarantors, the JV Subsidiary Guarantors (if any) or any other subsidiary or associated company of the Company, the Notes, the Subsidiary Guarantees or the JV Subsidiary Guarantees. The Notes will be traded on the SGX-ST in a minimum board lot size of CNY200,000 with a minimum of six lots to be traded in a single transaction for as long as the Notes are listed on the SGX-ST.

For so long as the Notes are listed on the SGX-ST and the rules of the SGX-ST so require, we will appoint and maintain a paying agent in Singapore where the Notes may be presented or surrendered for payment or redemption in the event that a Global Note is exchanged for definitive Notes. In addition, in the event that a Global Note is exchanged for definitive Notes, an announcement of such exchange will be made by or on behalf of us through the SGX-ST and such announcement will include all material information with respect to the delivery of the definitive Notes, including details of the paying agent in Singapore, for so long as the Notes are listed on the SGX-ST and the rules of the SGX-ST so require.

## INDEX TO FINANCIAL STATEMENTS

<b>Audited Consolidated Financial Statements as of and for the Year Ended December 31, 2012</b>	<b>2012 Annual Report<sup>(1)</sup></b>
Independent Auditor’s Report . . . . .	F-2 60
Consolidated Statement of Comprehensive Income . . . . .	F-3 61
Consolidated Statement of Financial Position . . . . .	F-4 62
Consolidated Statement of Changes in Equity . . . . .	F-6 64
Consolidated Statement of Cash Flows . . . . .	F-7 65
Notes to the Consolidated Financial Statements . . . . .	F-9 67
<b>Audited Consolidated Financial Statements as of and for the Year Ended December 31, 2011</b>	
Independent Auditor’s Report . . . . .	F-80 58
Consolidated Statement of Comprehensive Income . . . . .	F-81 59
Consolidated Statement of Financial Position . . . . .	F-82 60
Consolidated Statement of Changes in Equity . . . . .	F-84 62
Consolidated Statement of Cash Flows . . . . .	F-85 63
Notes to the Consolidated Financial Statements . . . . .	F-87 65

*Notes:*

- (1) *The audited consolidated financial statements set out herein has been reproduced from the Company’s annual report for the year ended December 31, 2012 and page references are to pages set forth in such report.*
- (2) *The audited consolidated financial statements set out herein have been reproduced from the Company’s annual report for the year ended December 31, 2011 and page references are to pages set forth in such report.*

# INDEPENDENT AUDITOR'S REPORT

# Deloitte.

## 德勤

TO THE MEMBERS OF FANTASIA HOLDINGS GROUP CO., LIMITED

花樣年控股集團有限公司

*(Incorporated in the Cayman Islands with limited liability)*

We have audited the consolidated financial statements of Fantasia Holdings Group Co., Limited (the "Company") and its subsidiaries (collectively referred to as the "Group") set out on pages 61 to 137, which comprise the consolidated statement of financial position as at 31 December 2012, and the consolidated statement of comprehensive income, consolidated statement of changes in equity and consolidated statement of cash flows for the year then ended, and a summary of significant accounting policies and other explanatory information.

## Directors' Responsibility for the Consolidated Financial Statements

The directors of the Company are responsible for the preparation of the consolidated financial statements that give a true and fair view in accordance with Hong Kong Financial Reporting Standards issued by the Hong Kong Institute of Certified Public Accountants and the disclosure requirements of the Hong Kong Companies Ordinance, and for such internal control as the directors determine is necessary to enable the preparation of the consolidated financial statements that are free from material misstatement, whether due to fraud or error.

## Auditor's Responsibility

Our responsibility is to express an opinion on these consolidated financial statements based on our audit and to report our opinion solely to you, as a body, in accordance with our agreed terms of engagement, and for no other purpose. We do not assume responsibility towards or accept liability to any other person for the contents of this report. We conducted our audit in accordance with Hong Kong Standards on Auditing issued by the Hong Kong Institute of Certified Public Accountants. Those standards require that we comply with ethical requirements and plan and perform the audit to obtain reasonable assurance about whether the consolidated financial statements are free from material misstatement.

An audit involves performing procedures to obtain audit evidence about the amounts and disclosures in the consolidated financial statements. The procedures selected depend on the auditor's judgment, including the assessment of the risks of material misstatement of the consolidated financial statements, whether due to fraud or error. In making those risk assessments, the auditor considers internal control relevant to the entity's preparation of the consolidated financial statements that give a true and fair view in order to design audit procedures that are appropriate in the circumstances, but not for the purpose of expressing an opinion on the effectiveness of the entity's internal control. An audit also includes evaluating the appropriateness of accounting policies used and the reasonableness of accounting estimates made by the directors, as well as evaluating the overall presentation of the consolidated financial statements.

We believe that the audit evidence we have obtained is sufficient and appropriate to provide a basis for our audit opinion.

## Opinion

In our opinion, the consolidated financial statements give a true and fair view of the state of affairs of the Group as at 31 December 2012, and of the Group's profit and cash flows for the year then ended in accordance with Hong Kong Financial Reporting Standards and have been properly prepared in accordance with the disclosure requirements of the Hong Kong Companies Ordinance.

**Deloitte Touche Tohmatsu**

*Certified Public Accountants*

Hong Kong

18 March 2013



# CONSOLIDATED STATEMENT OF COMPREHENSIVE INCOME

For the year ended 31 December 2012

	Notes	2012 RMB'000	2011 RMB'000 (restated)
Revenue	7	6,230,050	5,592,350
Cost of sales and services		(3,709,778)	(3,200,650)
Gross profit		2,520,272	2,391,700
Other income, gains and losses	8	31,800	46,922
Change in fair value of investment properties	16	167,876	182,980
Recognition of change in fair value of completed properties for sale upon transfer to investment properties	29	330,257	191,142
Selling and distribution expenses		(314,100)	(262,433)
Administrative expenses		(291,966)	(309,972)
Finance costs	9	(57,698)	(108,471)
Impairment loss recognised in respect of goodwill	26	–	(1,321)
Share of results of associates		417	171
Gain on disposal of an associate		–	3,533
Gain on disposal of a subsidiary	41	–	17,589
Profit before taxation	10	2,386,858	2,151,840
Income tax expense	11	(1,261,209)	(1,038,344)
Profit for the year		1,125,649	1,113,496
<b>Other comprehensive income (expense)</b>			
Surplus on revaluation of properties		45,708	11,795
Deferred taxation liability arising from revaluation of properties		(14,633)	(4,851)
Other comprehensive income for the year (net of income tax)		31,075	6,944
Total comprehensive income for the year		1,156,724	1,120,440
Profit for the year attributable to:			
Owners of the Company		1,139,241	1,057,479
Non-controlling interests		(13,592)	56,017
		1,125,649	1,113,496
Total comprehensive income attributable to:			
Owners of the Company		1,163,210	1,064,423
Non-controlling interests		(6,486)	56,017
		1,156,724	1,120,440
Earnings per share – Basic (RMB)	14	0.22	0.21
Earnings per share – Diluted (RMB)	14	0.22	0.21

# CONSOLIDATED STATEMENT OF FINANCIAL POSITION

At 31 December 2012

	Notes	31 December 2012 RMB'000	31 December 2011 RMB'000 (restated)	1 January 2011 RMB'000 (restated)
<b>NON-CURRENT ASSETS</b>				
Property, plant and equipment	15	585,687	529,215	374,434
Investment properties	16	3,422,233	2,443,694	1,697,677
Interests in associates	17	1,171	1,077	17,795
Interest in a jointly controlled entity	18	19,720	–	–
Advance to an associate	19	–	–	72,041
Goodwill	26	16,488	–	–
Prepaid lease payments	20	822,252	163,307	346,045
Premium on prepaid lease payments	21	591,144	440,275	359,203
Prepayment		–	11,890	43,370
Land development expenditure	22	1,217,463	1,335,848	393,849
Deposits paid for acquisition of subsidiaries	23	6,890	8,084	–
Deposit paid for acquisition of a property project	24	126,004	104,900	37,000
Deposit paid for acquisition of land use rights	25	158,123	–	763,095
Deferred tax assets	28	329,372	220,826	157,504
		7,296,547	5,259,116	4,262,013
<b>CURRENT ASSETS</b>				
Properties for sale	29	11,372,628	10,222,320	7,644,582
Prepaid lease payments	20	28,121	6,413	6,881
Premium on prepaid lease payments	21	19,219	11,157	6,101
Trade and other receivables	30	2,142,501	1,216,377	977,179
Amounts due from related parties	31	–	3,262	7,500
Amounts due from customers for contract works	32	52,482	16,359	15,939
Tax recoverable		77,179	51,143	5,580
Financial assets at fair value through profit or loss	33	42,200	–	–
Restricted bank deposits	34	707,614	315,134	85,161
Bank balances and cash	34	2,788,106	1,021,355	2,371,452
		17,230,050	12,863,520	11,120,375
<b>CURRENT LIABILITIES</b>				
Trade and other payables	35	2,603,457	2,268,829	1,686,718
Deposits received for sale of properties		4,186,104	2,619,004	1,834,067
Amounts due to customers for contract works	32	2,291	–	–
Amounts due to related parties	36	1,573	2,547	100,549
Tax payable		2,238,038	1,527,259	1,104,147
Borrowings – due within one year	37	2,452,294	2,100,069	2,132,381
		11,483,757	8,517,708	6,857,862
<b>NET CURRENT ASSETS</b>		5,746,293	4,345,812	4,262,513
<b>TOTAL ASSETS LESS CURRENT LIABILITIES</b>		13,042,840	9,604,928	8,524,526

	Notes	31 December 2012 RMB'000	31 December 2011 RMB'000 (restated)	1 January 2011 RMB'000 (restated)
<b>NON-CURRENT LIABILITIES</b>				
Deferred tax liabilities	28	692,558	429,372	247,099
Borrowings – due after one year	37	3,100,113	2,640,933	2,642,605
Senior notes	38	2,329,003	752,367	787,330
		6,121,674	3,822,672	3,677,034
		6,921,166	5,782,256	4,847,492
<b>CAPITAL AND RESERVES</b>				
Share capital	39	457,093	457,093	429,389
Reserves		6,144,037	5,144,506	4,002,262
Equity attributable to owners of the Company		6,601,130	5,601,599	4,431,651
Non-controlling interests		320,036	180,657	415,841
		6,921,166	5,782,256	4,847,492

The consolidated financial statements on pages 61 to 137 were approved and authorised for issue by the Board of Directors on 18 March 2013 and are signed on its behalf by:

**Pan Jun**  
DIRECTOR

**Lam Kam Tong**  
DIRECTOR

# CONSOLIDATED STATEMENT OF CHANGES IN EQUITY

For the year ended 31 December 2012

	Attributable to owners of the Company											
	Share capital RMB'000	Share premium RMB'000 (Note i)	Special reserve RMB'000 (Note ii)	Share options reserve RMB'000 (Note iii)	Contribution reserve RMB'000	Statutory reserves RMB'000 (Note iv)	Discretionary reserves RMB'000 (Note iv)	Property revaluation reserve RMB'000 (Note v)	Accumulated profits RMB'000	Total RMB'000	Non-controlling interests RMB'000	Total RMB'000
At 1 January 2011 (audited) (originally stated)	429,389	2,481,236	(901)	-	40,600	34,105	1,477	-	1,516,228	4,502,134	464,336	4,966,470
Adjustments (note 2)	-	-	-	-	-	-	-	-	(70,483)	(70,483)	(48,495)	(118,978)
At 1 January 2011 (restated)	429,389	2,481,236	(901)	-	40,600	34,105	1,477	-	1,445,745	4,431,651	415,841	4,847,492
Profit for the year	-	-	-	-	-	-	-	-	1,057,479	1,057,479	56,017	1,113,496
Surplus on revaluation of properties	-	-	-	-	-	-	-	11,795	-	11,795	-	11,795
Deferred taxation liability arising from revaluation of properties	-	-	-	-	-	-	-	(4,851)	-	(4,851)	-	(4,851)
Other comprehensive income for the year	-	-	-	-	-	-	-	6,944	-	6,944	-	6,944
Profit and total comprehensive income for the year (restated)	-	-	-	-	-	-	-	6,944	1,057,479	1,064,423	56,017	1,120,440
Issue of shares	27,704	304,736	-	-	-	-	-	-	-	332,440	-	332,440
Acquisition of additional interest in subsidiaries	-	-	(58,577)	-	-	-	-	-	-	(58,577)	(286,263)	(344,840)
Acquisition of subsidiaries (note 40(b))	-	-	-	-	-	-	-	-	-	-	(260)	(260)
Disposal of partial interest without loss of control	-	-	(4,690)	-	-	-	-	-	-	(4,690)	4,690	-
Disposal of a subsidiary (note 41)	-	-	-	-	-	-	-	-	-	-	(646)	(646)
Dividend paid to non-controlling shareholders	-	-	-	-	-	-	-	-	-	-	(8,722)	(8,722)
Dividend paid to shareholders of the Company (note 13)	-	(165,888)	-	-	-	-	-	-	-	(165,888)	-	(165,888)
Recognition of equity-settled share-based payments (note 44)	-	-	-	2,240	-	-	-	-	-	2,240	-	2,240
Transfer	-	-	-	-	-	6,303	-	-	(6,303)	-	-	-
At 31 December 2011 (restated)	457,093	2,620,084	(64,168)	2,240	40,600	40,408	1,477	6,944	2,496,921	5,601,599	180,657	5,782,256
Profit for the year	-	-	-	-	-	-	-	-	1,139,241	1,139,241	(13,592)	1,125,649
Surplus on revaluation of properties	-	-	-	-	-	-	-	36,233	-	36,233	9,475	45,708
Deferred taxation liability arising from revaluation of properties	-	-	-	-	-	-	-	(12,264)	-	(12,264)	(2,369)	(14,633)
Other comprehensive income for the year	-	-	-	-	-	-	-	23,969	-	23,969	7,106	31,075
Profit and total comprehensive income (expense) for the year	-	-	-	-	-	-	-	23,969	1,139,241	1,163,210	(6,486)	1,156,724
Acquisition of subsidiaries (note 40)	-	-	-	-	-	-	-	-	-	-	141,215	141,215
Contribution from non-controlling shareholders	-	-	-	-	-	-	-	-	-	-	4,650	4,650
Dividend paid to shareholders of the Company (note 13)	-	(168,859)	-	-	-	-	-	-	-	(168,859)	-	(168,859)
Recognition of equity-settled share-based payments (note 44)	-	-	-	5,180	-	-	-	-	-	5,180	-	5,180
Transfer	-	-	-	-	-	131	-	-	(131)	-	-	-
At 31 December 2012	457,093	2,451,225	(64,168)	7,420	40,600	40,539	1,477	30,913	3,636,031	6,601,130	320,036	6,921,166

## Notes:

- (i) Pursuant to article 16 of the Company's Article of Association, the Company is permitted to pay out final dividend from share premium account.
- (ii) Special reserve arising from the acquisition or disposal of equity interests in subsidiaries without loss of control represents the difference between the consideration paid or received and the adjustment to the non-controlling interests.
- (iii) Share options reserve represents the share-based payment under the Company's share option scheme.
- (iv) The statutory reserves and discretionary reserves relate to subsidiaries in the People's Republic of China (the "PRC") and are non-distributable. Transfers to these reserves are determined by the board of directors or the shareholders' meeting of the PRC subsidiaries in accordance with the relevant laws and regulations of the PRC. These reserves can be used to offset accumulated losses, expand the scale of production and business and increase capital upon approval from the relevant authorities.
- (v) Property revaluation surplus arose from the transfer of owner-occupied property to investment properties at the date of change in use.

# CONSOLIDATED STATEMENT OF CASH FLOWS

For the year ended 31 December 2012

	2012 RMB'000	2011 RMB'000
<b>OPERATING ACTIVITIES</b>		
Profit before taxation	2,386,858	2,151,840
Adjustments for:		
Change in fair value of investment properties	(167,876)	(182,980)
Recognition of change in fair value of completed properties for sale upon transfer to investment properties	(330,257)	(191,142)
Release of prepaid lease payments	12,102	4,824
Release of premium on prepaid lease payments	11,133	6,864
Release of prepayments	20,960	14,533
Depreciation of property, plant and equipment	37,478	21,474
Loss (gain) on disposal of property, plant and equipment	31	(5)
Impairment loss recognised in respect of goodwill	–	1,321
Allowance (reversal) on bad and doubtful debts, net	10,547	(265)
Interest income	(10,424)	(8,941)
Imputed interest income on non-current interest-free advance to an associate	–	(537)
Finance costs	57,698	108,471
Net foreign exchange gain	(7,483)	(28,573)
Share of results of associates	(417)	(171)
Share-based payment expenses	5,180	2,240
Gain on disposal of a subsidiary	–	(17,589)
Gain on disposal of an associate	–	(3,533)
Operating cash flows before movements in working capital	2,025,530	1,877,831
Addition to prepaid lease payments	(506,918)	(148,412)
Decrease (increase) in land development expenditure	238,955	(909,960)
Increase in properties for sale	(576,574)	(1,229,587)
Increase in deposits paid for acquisition of land use rights	(158,123)	–
Increase in trade and other receivables	(962,992)	(141,850)
Decrease in prepayments	10,000	17,000
Increase in amounts due from customers for contract works	(36,123)	(420)
(Decrease) increase in amounts due to related parties	(1,397)	2,547
Increase in amounts due to customers for contract works	2,291	–
Increase in trade and other payables	191,038	519,205
Increase in deposits received for sale of properties	1,567,100	784,937
Decrease in amounts due from related parties	–	7,500
Cash generated from operations	1,792,787	778,791
Enterprise income tax (“EIT”) paid, net	(191,844)	(218,726)
Land appreciation tax (“LAT”) paid	(244,626)	(326,729)
Interest paid	(510,313)	(436,914)
<b>NET CASH FROM (USED IN) OPERATING ACTIVITIES</b>	<b>846,004</b>	<b>(203,578)</b>

# CONSOLIDATED STATEMENT OF CASH FLOWS

For the year ended 31 December 2012

	Notes	2012 RMB'000	2011 RMB'000
<b>INVESTING ACTIVITIES</b>			
Deposits paid for acquisition of a property project		(21,104)	(67,900)
Increase in restricted bank deposits		(392,480)	(229,973)
Purchase of structured deposits		(42,200)	–
Settlement of consideration payable		(87,114)	(63,900)
Purchases of property, plant and equipment		(134,819)	(155,933)
Additions to investment properties		(149,580)	(273,973)
Acquisitions of assets and liabilities through acquisitions of subsidiaries (net of cash and cash equivalents acquired)	40(a)	(458,074)	(180,223)
Acquisition of business (net of cash and cash equivalents acquired)	40(b)	(53)	822
Interest received		10,424	8,941
Dividend received from an associate		323	–
Proceeds from disposal of property, plant and equipment		6,109	8,114
Disposal of a subsidiary	41	6,375	11,691
Disposal of an associate		–	96,000
Deposits paid for acquisition of subsidiaries		(5,680)	(8,084)
Proceeds from disposal of investment properties		21,856	1,450
Repayment (advance) of amounts due from related parties		3,262	(3,262)
Capital injection to a jointly controlled entity		(19,720)	–
<b>NET CASH USED IN INVESTING ACTIVITIES</b>		<b>(1,262,475)</b>	<b>(856,230)</b>
<b>FINANCING ACTIVITIES</b>			
Net proceeds from the issuance of senior notes	38	1,530,324	–
Contribution from a non-controlling shareholders		4,650	–
New borrowings raised		3,356,804	2,755,861
Repayment of borrowings		(2,539,965)	(2,738,576)
Dividend paid to shareholders of the Company		(168,859)	(165,888)
Dividend paid to non-controlling shareholders		–	(8,722)
Advance from (repayment to) a related party		423	(100,549)
Acquisition of additional interest in subsidiaries		–	(344,840)
Proceeds from issue of shares		–	332,440
<b>NET CASH FROM (USED IN) FINANCING ACTIVITIES</b>		<b>2,183,377</b>	<b>(270,274)</b>
<b>NET INCREASE (DECREASE) IN CASH AND CASH EQUIVALENTS</b>		<b>1,767,906</b>	<b>(1,330,082)</b>
<b>CASH AND CASH EQUIVALENTS AT THE BEGINNING OF THE YEAR</b>		<b>1,021,355</b>	<b>2,371,452</b>
Effect of foreign exchange rate changes		(1,155)	(20,015)
<b>CASH AND CASH EQUIVALENTS AT THE END OF THE YEAR,</b> represented by bank balances and cash		<b>2,788,106</b>	<b>1,021,355</b>

# NOTES TO THE CONSOLIDATED FINANCIAL STATEMENTS

For the year ended 31 December 2012

## 1. General

The Company was incorporated in the Cayman Islands on 17 October 2007 as an exempted company with limited liability under the Companies Law of the Cayman Islands. The shares of the Company have been listed on the Main Board of The Stock Exchange of Hong Kong Limited (the "SEHK") with effect from 25 November 2009. Its parent is Fantasy Pearl International Limited, a limited liability company incorporated in the British Virgin Islands (the "BVI"). Its ultimate holding company is Ice Apex Limited, a limited liability company also incorporated in the BVI. Its ultimate controlling party is Ms. Zeng Jie, Baby, who is a director of the Company. The address of the registered office of the Company is Cricket Square, Hutchins Drive, PO Box 2681, Grand Cayman KY 1-1111, Cayman Islands and its principal place of business in Hong Kong is Room 1103, Top Glory Tower, 262 Gloucester Road, Causeway Bay, Hong Kong while its principal place of business in the People's Republic of China (the "PRC") is 27/F, Block A, Hailun Complex, No.6021 Shennan Boulevard, Shenzhen 518040, Guangdong Province, the PRC.

The Company acts as an investment holding company. Details of the principal activities of its subsidiaries are set out in note 48.

The consolidated financial statements are presented in Renminbi ("RMB"), which is the functional currency of the Company.

## 2. Application of New and Revised Hong Kong Financial Reporting Standards ("HKFRSs")

In the current year, the Group has applied the following new and revised HKFRSs issued by the Hong Kong Institute of Certified Public Accountants ("HKICPA").

Amendments to HKAS 12  
Amendments to HKFRS 7  
Amendments to HKAS 1

Deferred tax: Recovery of Underlying Assets  
Financial Instruments: Disclosures – Transfers of Financial Assets  
As part of the Annual Improvements to HKFRSs 2009-2011  
Cycle issued in 2012

Except as described below, the application of the new and revised HKFRSs in the current year has had no material impact on the Group's financial performance and positions for the current and prior years and/or on the disclosures set out in these consolidated financial statements.

### Amendments to HKAS 1 *Presentation of Financial Statements* (as part of the Annual Improvements to HKFRSs 2009–2011 Cycle issued in June 2012)

Various amendments to HKFRSs were issued in June 2012, the title of which is Annual Improvements to HKFRSs 2009–2011 Cycle. The effective date of these amendments is annual periods beginning on or after 1 January 2013. In the current year, the Group has applied for the first time the amendments to HKAS 1 in advance of the effective date (annual periods beginning on or after 1 January 2013).

HKAS 1 requires an entity that changes accounting policies retrospectively, or makes a retrospective restatement or reclassification to present a statement of financial position as at the beginning of the preceding period (third statement of financial position). The amendments to HKAS 1 clarify that an entity is required to present a third statement of financial position only when the retrospective application, restatement or reclassification has a material effect on the information in the third statement of financial position and that related notes are not required to accompany the third statement of financial position.

In the current year, the Group has applied the amendments to HKAS 12 *Deferred Tax: Recovery of Underlying Assets* for the first time, which has resulted in a material effect on the information in the consolidated statement of financial position as at 1 January 2011. In accordance with the amendments to HKAS 1, the Group has therefore presented a third statement of financial position as at 1 January 2011 without the related notes.

## NOTES TO THE CONSOLIDATED FINANCIAL STATEMENTS

For the year ended 31 December 2012

### 2. Application of New and Revised Hong Kong Financial Reporting Standards (“HKFRSs”) (continued) Amendments to HKAS 12 *Deferred Tax: Recovery of Underlying Assets*

The Group has applied for the first time the amendments to HKAS 12 *Deferred Tax: Recovery of Underlying Assets* in the current year. Under the amendments, investment properties that are measured using the fair value model in accordance with HKAS 40 *Investment Property* are presumed to be recovered entirely through sale for the purposes of measuring deferred taxes, unless the presumption is rebutted in certain circumstances.

The Group measures its investment properties using the fair value model. As a result of the application of the amendments to HKAS 12, the directors reviewed the Group’s investment property portfolios and concluded that none of the Group’s investment properties are held under a business model whose objective is to consume substantially all of the economic benefits embodied in the investment properties over time. Therefore, the directors have determined that the ‘sale’ presumption set out in the amendments to HKAS 12 is not rebutted.

As a result of the application of the amendments to HKAS 12, the Group recognised additional deferred taxes in respect of those investment properties situated in the PRC which are not held under a business model whose objective is to consume substantially all of the economic benefits embodied in the investment properties over time and are subject to land appreciation tax and enterprise income tax on disposal of these investment properties.

Accordingly, the Group recognises the deferred taxes on changes in fair value of the investment properties taking into account the land appreciation tax and PRC enterprise income tax payable on disposal of these investment properties. Previously, the Group recognised deferred taxes on changes in fair value of investment properties using PRC enterprise income tax rate on the basis that the entire carrying amounts of the properties were recovered through use.

The amendments to HKAS 12 have been applied retrospectively, resulting in the Group’s deferred tax liabilities being increased by approximately RMB118,978,000 as at 1 January 2011, with the corresponding debit being recognised in retained earnings and non-controlling interests. Similarly, the deferred tax liabilities have been increased by approximately RMB217,025,000 as at 31 December 2011.

In the current year, deferred taxes have been provided for changes in fair value of the Group’s investment properties. The change in accounting policy has resulted in the Group’s income tax expense for the years ended 31 December 2012 and 31 December 2011 being increased by approximately RMB131,709,000 and RMB96,145,000 respectively and hence resulted in profit for the years ended 31 December 2012 and 31 December 2011 being decreased by the same amounts.

#### Summary of the effect of the above change in accounting policy

The effect of the change in accounting policy described above on the results for the current and preceding year by line items presented in the consolidated statement of comprehensive income is as follows:

	2012 RMB'000	2011 RMB'000
Increase in income tax expense and decrease in profit for the year	131,709	96,145
Increase in deferred tax charge recognised in other comprehensive income in relation to change in fair value of owner-occupied properties to investment properties	3,205	1,902



2. Application of New and Revised Hong Kong Financial Reporting Standards (“HKFRSs”) (continued)  
Summary of the effect of the above change in accounting policy (continued)

The effect of the change in accounting policy described above on the financial positions of the Group as at the end of the immediately preceding financial year, i.e. 31 December 2011, is as follows:

	As at 31 December 2011 (originally stated) RMB'000	Adjustments RMB'000	As at 31 December 2011 (restated) RMB'000
Deferred tax liabilities and total effect of net assets	212,347	217,025	429,372
Accumulated profits	2,663,549	(166,628)	2,496,921
Special reserve (Note)	(15,673)	(48,495)	(64,168)
Property revaluation reserve	8,846	(1,902)	6,944
<b>Total effect on equity</b>	<b>2,656,722</b>	<b>(217,025)</b>	<b>2,439,697</b>

The effect of the change in accounting policy described above on the financial positions of the Group as at the beginning of the comparative period, i.e. 1 January 2011, is as follows:

	As at 1 January 2011 (originally stated) RMB'000	Adjustments RMB'000	As at 1 January 2011 (restated) RMB'000
Deferred tax liabilities and total effect on net assets	128,121	118,978	247,099
Accumulated profits	1,516,228	(70,483)	1,445,745
Non-controlling interests	464,336	(48,495)	415,841
<b>Total effect on equity</b>	<b>1,980,564</b>	<b>(118,978)</b>	<b>1,861,586</b>

Note: In 2011, the Group acquired the non-controlling interests in two subsidiaries with the excess of the consideration paid over the adjustment to the carrying amount of the non-controlling interests being debited to special reserve in that year. The application of the amendments to HKAS 12 retrospectively has resulted in an increase in deferred tax liabilities and hence a decrease in the non-controlling interests of RMB48,495,000 at 1 January 2011. The application of the amendments has also resulted in special reserve being further debited by the same amount as at 31 December 2011.

## NOTES TO THE CONSOLIDATED FINANCIAL STATEMENTS

For the year ended 31 December 2012

### 2. Application of New and Revised Hong Kong Financial Reporting Standards (“HKFRSs”) (continued) Summary of the effect of the above change in accounting policy (continued)

	2012 RMB	2011 RMB
<b>Impact on basic earnings per share</b>		
Basic earnings per share before adjustment	0.24	0.23
Adjustments arising from change in accounting policy in relation to application of amendments to HKAS 12 in respect of deferred taxes on investment properties	(0.02)	(0.02)
Reported basic earnings per share	0.22	0.21
<b>Impact on diluted earnings per share</b>		
Diluted earnings per share before adjustment	0.24	0.23
Adjustments arising from change in accounting policy in relation to application of amendments to HKAS 12 in respect of deferred taxes on investment properties	(0.02)	(0.02)
Reported diluted earnings per share	0.22	0.21

#### ***New and revised HKFRSs issued but not yet effective***

The Group has not early applied the following new and revised HKFRSs that have been issued but are not yet effective:

Amendments to HKFRSs	Annual Improvements to HKFRSs 2009-2011 Cycle, except for the amendments HKAS 1 <sup>1</sup>
Amendments to HKFRS 7	Disclosures – Offsetting Financial Assets and Financial Liabilities <sup>1</sup>
Amendments to HKFRS 9 and HKFRS 7	Mandatory Effective Date of HKFRS 9 and Transition Disclosures <sup>3</sup>
Amendments to HKFRS 10, HKFRS 11 and HKFRS 12	Consolidated Financial Statements, Joint Arrangements and Disclosure of Interests in Other Entities: Transition Guidance <sup>1</sup>
Amendments to HKFRS 10, HKFRS 12 and HKAS 27	Investment Entities <sup>2</sup>
HKFRS 9	Financial Instruments <sup>3</sup>
HKFRS 10	Consolidated Financial Statements <sup>1</sup>
HKFRS 11	Joint Arrangement <sup>1</sup>
HKFRS 12	Disclosure of Interests in Other Entities <sup>1</sup>
HKFRS 13	Fair Value Measurement <sup>1</sup>
HKAS 19 (as revised in 2011)	Employee Benefits <sup>1</sup>
HKAS 27 (as revised in 2011)	Separate Financial Statements <sup>1</sup>
HKAS 28 (as revised in 2011)	Investments in Associates and Joint Ventures <sup>1</sup>
Amendments to HKAS 1	Presentation of Item of Other Comprehensive Income <sup>4</sup>
Amendments to HKAS 32	Offsetting Financial Assets and Financial Liabilities <sup>2</sup>
HKFRIC 20	Stripping Costs in the Production Phase of a Surface Mine <sup>1</sup>

<sup>1</sup> Effective for annual periods beginning on or after 1 January 2013

<sup>2</sup> Effective for annual periods beginning on or after 1 January 2014

<sup>3</sup> Effective for annual periods beginning on or after 1 January 2015

<sup>4</sup> Effective for annual periods beginning on or after 1 July 2012

#### ***Annual Improvements to HKFRSs 2009–2011 Cycle issued in June 2012***

The *Annual Improvements to HKFRSs 2009–2011 Cycle* include a number of amendments to various HKFRSs. The amendments are effective for annual periods beginning on or after 1 January 2013. Amendments to HKFRSs include the amendments to HKAS 16 *Property, Plant and Equipment* and the amendments to HKAS 32 *Financial Instruments: Presentation*.

## 2. Application of New and Revised Hong Kong Financial Reporting Standards (“HKFRSs”) (continued) Summary of the effect of the above change in accounting policy (continued)

### **Annual Improvements to HKFRSs 2009–2011 Cycle issued in June 2012** (continued)

The amendments to HKAS 16 clarify that spare parts, stand-by equipment and servicing equipment should be classified as property, plant and equipment when they meet the definition of property, plant and equipment in HKAS 16 and as inventory otherwise. The directors do not anticipate that the application of the amendments will have a material effect on the Group’s consolidated financial statements.

The amendments to HKAS 32 clarify that income tax on distributions to holders of an equity instrument and transaction costs of an equity transaction should be accounted for in accordance with HKAS 12 *Income Taxes*. The directors do not anticipate that the application of the amendments to HKAS 32 will have a material effect on the Group’s consolidated financial statements.

### **HKFRS 9 *Financial Instruments***

HKFRS 9 issued in 2009 introduces new requirements for the classification and measurement of financial assets. HKFRS 9 amended in 2010 includes the requirements for the classification and measurement of financial liabilities and for derecognition.

Key requirements of HKFRS 9 are described as follows:

All recognised financial assets that are within the scope of HKAS 39 *Financial Instruments: Recognition and Measurement* are subsequently measured at amortised cost or fair value. Specifically, debt investments that are held within a business model whose objective is to collect the contractual cash flows, and that have contractual cash flows that are solely payments of principal and interest on the principal outstanding are generally measured at amortised cost at the end of subsequent accounting periods. All other debt investments and equity investments are measured at their fair values at the end of subsequent reporting periods. In addition, under HKFRS 9, entities may make an irrevocable election to present subsequent changes in the fair value of an equity investment (that is not held for trading) in other comprehensive income, with only dividend income generally recognised in profit or loss.

With regard to the measurement of financial liabilities designated as at fair value through profit or loss, HKFRS 9 requires that the amount of change in the fair value of the financial liability that is attributable to changes in the credit risk of that liability is presented in other comprehensive income, unless the recognition of the effects of changes in the liability’s credit risk in other comprehensive income would create or enlarge an accounting mismatch in profit or loss. Changes in fair value of financial liabilities attributable to changes in the financial liabilities’ credit risk are not subsequently reclassified to profit or loss. Under HKAS 39, the entire amount of the change in the fair value of the financial liability designated as fair value through profit or loss was presented in profit or loss. HKFRS 9 is effective for annual periods beginning on or after 1 January 2015, with earlier application permitted.

The directors do not anticipate that the application of the amendments to HKAS 9 will have a material effect on the Group’s consolidated financial statements.

### ***New and revised Standards on consolidation, joint arrangements, associates and disclosures***

In June 2011, a package of five standards on consolidation, joint arrangements, associates and disclosures was issued, including HKFRS 10, HKFRS 11, HKFRS 12, HKAS 27 (as revised in 2011) and HKAS 28 (as revised in 2011).

Key requirements of these five standards are described below.

HKFRS 10 replaces the parts of HKAS 27 Consolidated and Separate Financial Statements that deal with consolidated financial statements and SIC-Int 12 Consolidation – Special Purpose Entities. HKFRS 10 includes a new definition of control that contains three elements: (a) power over an investee, (b) exposure, or rights, to variable returns from its involvement with the investee, and (c) the ability to use its power over the investee to affect the amount of the investor’s returns. Extensive guidance has been added in HKFRS 10 to deal with complex scenarios.

HKFRS 11 replaces HKAS 31 *Interests in Joint Venture*. HKFRS 11 deals with how a joint arrangement of which two or more parties have joint control should be classified. SIC-Int 13 *Jointly Controlled Entities – Non-monetary Contributions by Venturers* will be withdrawn upon the effective date of HKFRS 11. Under HKFRS 11, joint arrangements are classified as joint operations or joint ventures, depending on the rights and obligations of the parties to the arrangements. In contrast, under HKAS 31, there are three types of joint arrangements: jointly controlled entities, jointly controlled assets and jointly controlled operations. In addition, joint ventures under HKFRS 11 are required to be accounted for using the equity method of accounting, whereas jointly controlled entities under HKAS 31 can be accounted for using the equity method of accounting or proportionate consolidation.

## NOTES TO THE CONSOLIDATED FINANCIAL STATEMENTS

For the year ended 31 December 2012

### 2. Application of New and Revised Hong Kong Financial Reporting Standards (“HKFRSs”) (continued)

#### HKFRS 9 *Financial Instruments* (continued)

##### ***New and revised Standards on consolidation, joint arrangements, associates and disclosures*** (continued)

HKFRS 12 is a disclosure standard and is applicable to entities that have interests in subsidiaries, joint arrangements, associates and/or unconsolidated structured entities. In general, the disclosure requirements in HKFRS 12 are more extensive than those in the current standards.

In July 2012, the amendments to HKFRS 10, HKFRS 11 and HKFRS 12 were issued to clarify certain transitional guidance on the application of these five HKFRSs for the first time.

These five standards, together with the amendments relating to the transitional guidance, are effective for annual periods beginning on or after 1 January 2013 with earlier application permitted provided that all of these standards are applied early at the same time.

The directors anticipate that the application of these five standards may not have significant impact on amounts reported in the consolidated financial statements when the new standards are applied in the future accounting periods.

#### HKFRS 13 *Fair Value Measurement*

HKFRS 13 establishes a single source of guidance for fair value measurements and disclosures about fair value measurements. The standard defines fair value, establishes a framework for measuring fair value, and requires disclosures about fair value measurements. The scope of HKFRS 13 is broad; it applies to both financial instrument items and non-financial instrument items for which other HKFRSs require or permit fair value measurements and disclosures about fair value measurements, except in specified circumstances. In general, the disclosure requirements in HKFRS 13 are more extensive than those in the current standards. For example, quantitative and qualitative disclosures based on the three-level fair value hierarchy currently required for financial instruments only under HKFRS 7 *Financial Instruments: Disclosures* will be extended by HKFRS 13 to cover all assets and liabilities within its scope.

HKFRS 13 is effective for annual periods beginning on or after 1 January 2013, with earlier application permitted. The directors anticipate that the application of the new standard may affect certain amounts reported in the consolidated financial statements and result in more extensive disclosures in the consolidated financial statements.

#### Amendments to HKAS 1 *Presentation of Items of Other Comprehensive Income*

The amendments to HKAS 1 *Presentation of Items of Other Comprehensive Income* introduce new terminology for the statement of comprehensive income and income statement. Under the amendments to HKAS 1, a ‘statement of comprehensive income’ is renamed as a ‘statement of profit or loss and other comprehensive income’ and an ‘income statement’ is renamed as a ‘statement of profit or loss’. The amendments to HKAS 1 retain the option to present profit or loss and other comprehensive income in either a single statement or in two separate but consecutive statements. However, the amendments to HKAS 1 require items of other comprehensive income to be grouped into two categories: (a) items that will not be reclassified subsequently to profit or loss; and (b) items that may be reclassified subsequently to profit or loss when specific conditions are met. Income tax on items of other comprehensive income is required to be allocated on the same basis – the amendments do not change the option to present items of other comprehensive income either before tax or net of tax.

The amendments to HKAS 1 are effective for annual periods beginning on or after 1 July 2012. The presentation of items of other comprehensive income will be modified accordingly when the amendments are applied in future accounting periods.

### 3. Significant Accounting Policies

The consolidated financial statements have been prepared in accordance with Hong Kong Financial Reporting Standards issued by the HKICPA. In addition, the consolidated financial statements include applicable disclosures required by the Rules Governing the Listing of Securities on The Stock Exchange of Hong Kong Limited and by the Hong Kong Companies Ordinance.

The consolidated financial statements have been prepared on the historical cost basis, except for certain properties and financial instruments that are measured at fair values, as explained in the accounting policies set out below. Historical cost is generally based on the fair value of the consideration given in exchange for goods.

The significant accounting policies are set out below.

#### Basis of consolidation

The consolidated financial statements incorporate the financial statements of the Company and entities controlled by the Company (its subsidiaries). Control is achieved where the Company has the power to govern the financial and operating policies of an entity so as to obtain benefits from its activities.

Income and expenses of subsidiaries acquired or disposed of during the year are included in the consolidated statement of comprehensive income from the effective date of acquisition and up to the effective date of disposal, as appropriate.

Where necessary, adjustments are made to the financial statements of subsidiaries to bring their accounting policies into line with those used by other members of the Group.

All intra-group transactions, balances, income and expenses are eliminated on consolidation.

Non-controlling interests in subsidiaries are presented separately from the Group's equity therein.

#### **Allocation of total comprehensive income to non-controlling interests**

Total comprehensive income and expense of a subsidiary is attributed to the owners of the Company and to the non-controlling interests even if this results in the non-controlling interests having a deficit balance (effective from 1 January 2010 onwards).

#### **Changes in the Group's ownership interests in existing subsidiaries**

Changes in the Group's ownership interests in existing subsidiaries that do not result in the Group losing control over the subsidiaries are accounted for as equity transactions. The carrying amounts of the Group's interests and the non-controlling interests are adjusted to reflect the changes in their relative interests in the subsidiaries. Any difference between the amount by which the non-controlling interests are adjusted and the fair value of the consideration paid or received is recognised directly in equity and attributed to owners of the Company.

When the Group loses control of a subsidiary, it (i) derecognises the assets (including any goodwill) and liabilities of the subsidiary at their carrying amounts at the date when control is lost, (ii) derecognises the carrying amount of any non-controlling interests in the former subsidiary at the date when control is lost (including any components of other comprehensive income attributable to them), and (iii) recognises the aggregate of the fair value of the consideration received and the fair value of any retained interest, with any resulting difference being recognised as a gain or loss in profit or loss attributable to the Group. When assets of the subsidiary are carried at revalued amounts or fair values and the related cumulative gain or loss has been recognised in other comprehensive income and accumulated in equity, the amounts previously recognised in other comprehensive income and accumulated in equity are accounted for as if the Group had directly disposed of the related assets (i.e. reclassified to profit or loss or transferred directly to retained earnings as specified by applicable HKFRSs). The fair value of any investment retained in the former subsidiary at the date when control is lost is regarded as the fair value on initial recognition for subsequent accounting under HKAS 39 *Financial Instruments: Recognition and Measurement* or, when applicable, the cost on initial recognition of an investment in an associate or a jointly controlled entity.

# NOTES TO THE CONSOLIDATED FINANCIAL STATEMENTS

For the year ended 31 December 2012

## 3. Significant Accounting Policies (Continued)

### Business combinations

Acquisitions of businesses are accounted for using the acquisition method. The consideration transferred in a business combination is measured at fair value, which is calculated as the sum of the acquisition-date fair values of the assets transferred by the Group, liabilities incurred by the Group to the former owners of the acquiree and the equity interests issued by the Group in exchange for control of the acquiree. Acquisition-related costs are generally recognised in profit or loss as incurred.

At the acquisition date, the identifiable assets acquired and the liabilities assumed are recognised at their fair value at the acquisition date, except that:

- deferred tax assets or liabilities and liabilities or assets related to employee benefit arrangements are recognised and measured in accordance with HKAS 12 *Income Taxes* and HKAS 19 *Employee Benefits* respectively;
- liabilities or equity instruments related to share-based payment transactions of the acquiree or the replacement of an acquiree's share-based payment transactions with share-based payment transactions of the Group are measured in accordance with HKFRS 2 *Share-based Payment* at the acquisition date (see the accounting policy below); and
- assets (or disposal groups) that are classified as held for sale in accordance with HKFRS 5 *Non-current Assets Held for Sale and Discontinued Operations* are measured in accordance with that Standard.

Goodwill is measured as the excess of the sum of the consideration transferred, the amount of any non-controlling interests in the acquiree, and the fair value of the acquirer's previously held equity interest in the acquiree (if any) over the net of the acquisition-date amounts of the identifiable assets acquired and the liabilities assumed. If, after re-assessment, the net of the acquisition-date amounts of the identifiable assets acquired and liabilities assumed exceeds the sum of the consideration transferred, the amount of any non-controlling interests in the acquiree and the fair value of the acquirer's previously held interest in the acquiree (if any), the excess is recognised immediately in profit or loss as a bargain purchase gain.

Non-controlling interests that are present ownership interests and entitle their holders to a proportionate share of the entity's net assets in the event of liquidation may be initially measured either at fair value or at the non-controlling interests' proportionate share of the recognised amounts of the acquiree's identifiable net assets. The choice of measurement basis is made on a transaction-by-transaction basis. Other types of non-controlling interests are measured at their fair value or, when applicable, on the basis specified in another Standard.

### Goodwill

Goodwill arising on an acquisition of a business is carried at cost less any accumulated impairment losses and is presented separately in the consolidated statement of financial position.

For the purposes of impairment testing, goodwill is allocated to each of the relevant cash-generating units (or groups of cash generating units) that is expected to benefit from the synergies of the combination.

A cash-generating unit to which goodwill has been allocated is tested for impairment annually, or more frequent whenever there is indication that the unit may be impaired. For goodwill arising on an acquisition in a reporting period, the cash-generating unit to which goodwill has been allocated is tested for impairment before the end of that reporting period. If the recoverable amount of the cash-generating unit is less than the carrying amount of the unit, the impairment loss is allocated first to reduce the carrying amount of any goodwill allocated to the unit and then to the other assets of the unit pro-rata on the basis of the carrying amount of each asset in the unit. Any impairment loss for goodwill is recognised directly in profit or loss in the consolidated statement of comprehensive income. An impairment loss recognised for goodwill is not reversed in a subsequent periods.

On subsequent disposal of the relevant cash-generating unit, the attributable amount of goodwill is included in the determination of the amount of profit or loss on disposal.

### Property, plant and equipment

Property, plant and equipment including buildings held for use in the production or supply of goods or services, or for administrative purposes (other than properties under construction as described below) are stated in the consolidated statement of financial position at cost less subsequent accumulated depreciation and accumulated impairment losses, if any.

### 3. Significant Accounting Policies (Continued)

#### Property, plant and equipment (continued)

Depreciation is recognised so as to write off the cost of items of property, plant and equipment other than construction in progress less their residual values over their estimated useful lives, using the straight-line method. The estimated useful lives, residual values and depreciation method are reviewed at the end of each reporting period, with the effect of any changes in estimate accounted for on a prospective basis.

Properties in the course of construction for production, supply or administrative purposes are carried at cost, less any recognised impairment loss. Costs include professional fees and, for qualifying assets, borrowing costs capitalised in accordance with the Group's accounting policy. Such properties are classified to the appropriate categories of property, plant and equipment when completed and ready for intended use. Depreciation of these assets, on the same basis as other property assets, commences when the assets are ready for their intended use.

If an item of property, plant and equipment becomes an investment property because its use has changed as evidenced by end of owner-occupation, any difference between the carrying amount and the fair value of that item at the date of transfer is recognised in other comprehensive income and accumulated in property revaluation reserve. On the subsequent sale or retirement of the asset, the relevant revaluation reserve will be transferred directly to retained profits.

An item of property, plant and equipment is derecognised upon disposal or when no future economic benefits are expected to arise from the continued use of the asset. Any gain or loss arising on the disposal or retirement of an item of property, plant and equipment is determined as the difference between the sales proceeds and the carrying amount of the asset and is recognised in profit or loss.

#### Buildings under development for future owner-occupied purpose

When buildings are in the course of development for production or for administrative purposes, the amortisation of prepaid lease payments provided during the construction period is included as part of costs of buildings under construction. Buildings under construction are carried at cost, less any identified impairment losses. Depreciation of buildings commences when they are available for use (i.e. when they are in the location and condition necessary for them to be capable of operating in the manner intended by management).

#### Investment properties

Investment properties are properties held to earn rentals and/or for capital appreciation including properties under construction for such purposes.

Investment properties are initially measured at cost, including any directly attributable expenditure. Subsequent to initial recognition, investment properties are measured at their fair values using the fair value model. Gains or losses arising from changes in the fair value of investment property are included in profit or loss for the period in which they arise.

Construction costs incurred for investment properties under construction are capitalised as part of the carrying amount of the investment properties under construction.

Property that is being constructed or developed for future use as investment property is classified as investment property. If the fair value cannot be reliably determined, the investment property under development will be measured at cost until such time as fair value can be determined or construction is completed.

An investment property is derecognised upon disposal or when the investment property is permanently withdrawn from use and no future economic benefits are expected from its disposals. Any gain or loss arising on derecognition of the asset (calculated as the difference between the net disposal proceeds and the carrying amount of the asset) is included in the profit or loss in the period in which the item is derecognised.

# NOTES TO THE CONSOLIDATED FINANCIAL STATEMENTS

For the year ended 31 December 2012

## 3. Significant Accounting Policies (Continued)

### Interests in associates

An associate is an entity over which the Group has significant influence and that is neither a subsidiary nor an interest in a joint venture. Significant influence is the power to participate in the financial and operating policy decisions of the investee but is not control or joint control over those policies.

The results and assets and liabilities of associates are incorporated in these consolidated financial statements using the equity method of accounting. The financial statements of associates used for equity accounting purposes are prepared using uniform accounting policies as those of the Group for like transactions and events in similar circumstances. The associate uses accounting policies that differ from those of the Group for like transactions and events in similar circumstances. Appropriate adjustments have been made to conform the associates' accounting policies to those of the Group. Under the equity method, investments in associates are initially recognised in the consolidated statement of financial position at cost and adjusted thereafter to recognise the Group's share of the profit or loss and other comprehensive income of the associates. When the Group's share of losses of an associate exceeds the Group's interest in that associate (which includes any long-term interests that, in substance, form part of the Group's net investment in the associate), the Group discontinues recognising its share of further losses. Additional losses are recognised only to the extent that the Group has incurred legal or constructive obligations or made payments on behalf of the associate.

Any excess of the cost of acquisition over the Group's share of the net fair value of the identifiable assets, liabilities and contingent liabilities of an associate recognised at the date of acquisition is recognised as goodwill, which is included within the carrying amount of the investment.

Any excess of the Group's share of the net fair value of the identifiable assets, liabilities and contingent liabilities over the cost of acquisition, after reassessment, is recognised immediately in profit or loss.

The requirements of HKAS 39 are applied to determine whether it is necessary to recognise any impairment loss with respect to the Group's investment in an associate. When necessary, the entire carrying amount of the investment (including goodwill) is tested for impairment in accordance with HKAS 36 *Impairment of Assets* as a single asset by comparing its recoverable amount (higher of value in use and fair value less costs to sell) with its carrying amount, any impairment loss recognised forms part of the carrying amount of the investment. Any reversal of that impairment loss is recognised in accordance with HKAS 36 to the extent that the recoverable amount of the investment subsequently increases.

When a group entity transacts with its associate, profits and losses resulting from the transactions with the associate are recognised in the Group's consolidated financial statements only to the extent of interests in the associate that are not related to the Group.

### Jointly controlled entities

Joint venture arrangements that involve the establishment of a separate entity in which venturers have joint control over the economic activity are referred to as jointly controlled entities.

The results and assets and liabilities of jointly controlled entities are incorporated in the consolidated financial statements using the equity method of accounting. Under the equity method, investments in jointly controlled entities are initially recognised in the consolidated statement of financial position at cost and adjusted thereafter to recognise the Group's share of the profit or loss and other comprehensive income of the jointly controlled entities. When the Group's share of losses of a jointly controlled entity equals or exceeds its interest in that jointly controlled entity (which includes any long-term interests that, in substance, form part of the Group's net investment in the jointly controlled entity), the Group discontinues recognising its share of further losses. Additional losses are recognised only to the extent that the Group has incurred legal or constructive obligations or made payments on behalf of that jointly controlled entity.

The requirements of HKAS 39 are applied to determine whether it is necessary to recognise any impairment loss with respect to the Group's investment in a jointly controlled entity. When necessary, the entire carrying amount of the investment (including goodwill) is tested for impairment in accordance with HKAS 36 *Impairment of Assets* as a single asset by comparing its recoverable amount (higher of value in use and fair value less costs to sell) with its carrying amount. Any impairment loss recognised forms part of the carrying amount of the investment. Any reversal of that impairment loss is recognised in accordance with HKAS 36 to the extent that the recoverable amount of the investment subsequently increases.



### 3. Significant Accounting Policies (Continued)

#### Land development expenditure

Land development expenditure is stated at the lower of cost and net realisable value. The cost includes expenditure directly attributable to the development of relevant projects such as road construction, demolition, resettlement work and borrowing cost.

#### Properties for sale

Completed properties and properties under development for sale in the ordinary course of business are included in current assets and stated at the lower of cost and net realisable value. Cost includes the cost of land, development expenditure, borrowing costs capitalised in accordance with the Group's accounting policy, and other attributable expenses.

Net realisable value represents the estimated selling price for properties for sale less all estimated costs of completion and costs necessary to make the sale.

The Group transfers a property from inventories to investment property when there is a change of intention to hold the property to earn rentals or/and for capital appreciation rather than for sale in the ordinary course of business, which is evidenced by the commencement of an operating lease to another party. Any difference between the fair value of the property at the date of transfer and its previous carrying amount is recognised in profit or loss.

#### Installation contracts

Where the outcome of the installation contract can be estimated reliably, revenue and costs are recognised by reference to the stage of completion of the contract activity at the end of the reporting period, as measured by reference to the proportion that value of works performed to date, which is reflected by the billings agreed with the customer to date, relative to the estimated total revenue for each contract. Variations in contract work, claims and incentive payments are included to the extent that the amount can be measured reliably and its receipt is considered probable.

Where the outcome of a contract cannot be estimated reliably, contract revenue is recognised to the extent of contract costs incurred that it is probable will be recoverable. Contract costs are recognised as expenses in the period in which they are incurred.

When it is probable that total contract costs will exceed total contract revenue, the expected loss is recognised as an expense immediately.

Where contract costs incurred to date plus recognised profits less recognised losses exceed progress billings, the surplus is shown as amounts due from customers for contract works. For contracts where progress billings exceed contract costs incurred to date plus recognised profits less recognised losses, the surplus is shown as amounts due to customers for contract works. Amounts received before the related work is performed are included in the consolidated statement of financial position, as a liability, as advance received included in other payables. Amounts billed for work performed but not yet paid by the customer are included in the consolidated statement of financial position under trade and other receivables.

#### Financial instruments

Financial assets and financial liabilities are recognised in the consolidated statement of financial position when a group entity becomes a party to the contractual provisions of the instrument.

Financial assets and financial liabilities are initially measured at fair value. Transaction costs that are directly attributable to the acquisition or issue of financial assets and financial liabilities (other than financial assets and financial liabilities at fair value through profit or loss) are added to or deducted from the fair values of the financial assets or financial liabilities, as appropriate, on initial recognition. Transaction costs directly attributable to the acquisition of financial assets or financial liabilities at fair value through profit or loss are recognised immediately in profit or loss.

# NOTES TO THE CONSOLIDATED FINANCIAL STATEMENTS

For the year ended 31 December 2012

## 3. Significant Accounting Policies (Continued)

### Financial instruments (continued)

#### **Financial assets**

The Group's financial assets are generally classified as, loans and receivables and financial assets at fair value through profit or loss ("FVTPL"). The classification depends on the nature and purpose of the financial assets and is determined at the time of initial recognition.

#### *Loans and receivables*

Loans and receivables are non-derivative financial assets with fixed or determinable payments that are not quoted in an active market. Subsequent to initial recognition, loans and receivables (including advance to an associate, deposits paid for acquisition of land use rights, subsidiaries and a property project, trade and other receivables, amounts due from related parties, restricted bank deposits and bank balances and cash) are carried at amortised cost using the effective interest method, less any identified impairment losses (see accounting policy on impairment of financial assets below).

#### Effective interest method

The effective interest method is a method of calculating the amortised cost of a financial asset and of allocating interest income over the relevant period. The effective interest rate is the rate that exactly discounts estimated future cash receipts (including all fees paid or received that form an integral part of the effective interest rate, transaction costs and other premiums or discounts) through the expected life of the financial asset, or, where appropriate, a shorter period to the net carrying amount on initial recognition.

Interest income is recognised on an effective interest basis for debt instruments.

#### *Financial assets at fair value through profit or loss*

Financial assets at FVTPL represent those designated as at FVTPL on initial recognition.

A financial asset may be designated as at FVTPL upon initial recognition if:

- such designation eliminates or significantly reduces a measurement or recognition inconsistency that would otherwise arise; or
- the financial asset forms part of a group of financial assets or financial liabilities or both, which is managed and its performance is evaluated on a fair value basis, in accordance with the Group's documented risk management or investment strategy, and information about the grouping is provided internally on that basis; or
- it forms part of a contract containing one or more embedded derivatives, and HKAS 39 permits the entire combined contract (asset or liability) to be designated as at FVTPL.

Financial assets at FVTPL are measured at fair value, with changes in fair value arising from remeasurement recognised directly in profit or loss in the period in which they arise. The net gain or loss recognised in profit or loss includes any dividend or interest earned on the financial assets. Fair value is determined in the manner described in note 33.

#### **Impairment of financial assets**

Financial assets other than those at FVTPL are assessed for indicators of impairment at the end of the reporting period. Financial assets are considered to be impaired where there is objective evidence that, as a result of one or more events that occurred after the initial recognition of the financial asset, the estimated future cash flows of the financial assets have been affected.

Objective evidence of impairment could include:

- significant financial difficulty of the issuer or counterparty; or
- breach of contract, such as default or delinquency in interest and principal payments; or
- it becoming probable that the borrower will enter bankruptcy or financial re-organisation; or
- disappearance of an active market for that financial asset because of financial difficulties.

### 3. Significant Accounting Policies (Continued)

#### Financial instruments (continued)

##### **Impairment of financial assets** (continued)

For certain categories of financial asset, such as trade receivables, assets that are assessed not to be impaired individually are subsequently assessed for impairment on a collective basis. Objective evidence of impairment for a portfolio of receivables could include the Group's past experience of collecting payments, an increase in the number of delayed payments in the portfolio past the average credit period, observable changes in national or local economic conditions that correlate with default on receivables.

For financial assets carried at amortised cost, the amount of the impairment loss recognised is the difference between the asset's carrying amount and the present value of the estimated future cash flows discounted at the financial asset's original effective interest rate.

The amount of the impairment loss recognised is the difference between the asset's carrying amount and the present value of the estimated future cash flows discounted at the financial asset's original effective interest rate.

The carrying amount of the financial asset is reduced by the impairment loss directly with the exception of trade receivables, where the carrying amount is reduced through the use of an allowance account. Changes in the carrying amount of the allowance account are recognised in profit or loss. When trade receivables are considered uncollectible, it is written off against the allowance account. Subsequent recoveries of amounts previously written off are credited to profit or loss.

For financial assets measured at amortised cost, if, in a subsequent period, the amount of the impairment loss decreases and the decrease can be related objectively to an event occurring after the impairment loss was recognised, the previously recognised impairment loss is reversed through profit or loss to the extent that the carrying amount of the asset at the date the impairment is reversed does not exceed what the amortised cost would have been had the impairment not been recognised.

##### **Financial liabilities and equity instruments**

Debt and equity instruments issued by a group entity are classified as either financial liabilities or as equity in accordance with the substance of the contractual arrangements entered into and the definitions of a financial liability and an equity instrument.

##### *Other financial liabilities*

Other financial liabilities (including trade and other payables, amounts due to related parties, borrowings and senior notes) are subsequently measured at amortised cost, using the effective interest method.

##### *Effective interest method*

The effective interest method is a method of calculating the amortised cost of a financial liability and of allocating interest expense over the relevant period. The effective interest rate is the rate that exactly discounts estimated future cash payments (including all fees paid or received that form an integral part of the effective interest rate, transaction costs and other premiums or discounts) through the expected life of the financial liability, or, where appropriate, a shorter period, to the net carrying amount on initial recognition.

Interest expense is recognised on an effective interest basis.

##### *Senior notes*

Senior notes issued by the Group that contain both liability and early redemption option (which is not closely related to the host contract) are classified separately into respective items on initial recognition. At the date of issue, both the liability and early redemption option components are recognised at fair value.

In subsequent periods, the liability component of the senior notes is carried at amortised cost using the effective interest method. The early redemption option is measured at fair value with changes in fair value recognised in profit or loss.

Transaction costs that relate to the issue of the senior notes are allocated to the liability and early redemption option components in proportion to their relative fair values. Transaction costs relating to the early redemption option are charged to profit or loss immediately. Transaction costs relating to the liability component are included in the carrying amount of the liability portion and amortised over the period of the senior notes using the effective interest method.

# NOTES TO THE CONSOLIDATED FINANCIAL STATEMENTS

For the year ended 31 December 2012

## 3. Significant Accounting Policies (Continued)

### Financial instruments (continued)

#### *Equity instruments*

An equity instrument is any contract that evidences a residual interest in the assets of the Group after deducting all of its liabilities. Equity instruments issued by the Group are recognised at the proceeds received, net of direct issue costs.

#### *Embedded derivatives*

Derivatives embedded in non-derivative host contracts are treated as separate derivatives when their risks and characteristics are not closely related to those of the host contracts and the host contracts are not measured at fair value with changes in fair value recognised in profit or loss.

#### *Financial guarantee contracts*

A financial guarantee contract is a contract that requires the issuer to make specified payments to reimburse the holder for a loss it incurs because a specified debtor fails to make payment when due in accordance with the original or modified terms of a debt instrument.

A financial guarantee contract issued by the Group and not designated at fair value through profit or loss is recognised initially at its fair value less transaction costs that are directly attributable to the issue of the financial guarantee contract. Subsequent to initial recognition, the Group measures the financial guarantee contract at the higher of: (i) the amount of obligation under the contract, as determined in accordance with HKAS 37 *Provisions, Contingent Liabilities and Contingent Assets*, and (ii) the amount initially recognised less, when appropriate, cumulative amortisation recognised in accordance with the revenue recognition policy.

#### *Derecognition*

The Group derecognises a financial asset only when the contractual rights to the cash flows from the asset expire, or when it transfers the financial asset and substantially all the risks and rewards of ownership of the asset to another entity. If the Group neither transfers nor retains substantially all the risks and rewards of ownership and continues to control the transferred asset, the Group continues to recognise the asset to the extent of its continuing involvement and recognises an associated liability. If the Group retains substantially all the risks and rewards of ownership of a transferred financial asset, the Group continues to recognise the financial asset and also recognises a collateralised borrowing for the proceeds received.

On derecognition of a financial asset in its entirety, the difference between the asset's carrying amount and the sum of the consideration received and receivable and the cumulative gain or loss that had been recognised in other comprehensive income and accumulated in equity is recognised in profit or loss.

The Group derecognises financial liabilities when, and only when, the Group's obligations are discharged, cancelled or expire. The difference between the carrying amount of the financial liability derecognised and the consideration paid and payable is recognised in profit or loss.

#### *Impairment losses on tangible assets other than goodwill (see accounting policy in respect of goodwill above)*

At the end of the reporting period, the Group reviews the carrying amounts of its tangible assets to determine whether there is any indication that those assets have suffered an impairment loss. If any such indication exists, the recoverable amount of the asset is estimated in order to determine the extent of the impairment loss, if any. When it is not possible to estimate the recoverable amount of an individual asset, the Group estimates the recoverable amount of the cash-generating unit to which the asset belongs. Where a reasonable and consistent basis of allocation can be identified, corporate assets are also allocated to individual cash-generating units, or otherwise they are allocated to the smallest group of cash-generating units for which a reasonable and consistent allocation basis can be identified.

Recoverable amount is the higher of fair value less costs to sell and value in use. In assessing value in use, the estimated future cash flows are discounted to their present value using a pre-tax discount rate that reflects current market assessments of the time value of money and the risks specific to the asset for which the estimates of future cash flows have not been adjusted.

If the recoverable amount of an asset (or a cash-generating unit) is estimated to be less than its carrying amount, the carrying amount of the asset (or a cash-generating unit) is reduced to its recoverable amount. An impairment loss is recognised immediately in profit or loss, unless the relevant asset is carried at a revalued amount under another standard, in which case the impairment loss is treated as a revaluation decrease under that standard.

Where an impairment loss subsequently reverses, the carrying amount of the asset is increased to the revised estimate of its recoverable amount, but so that the increased carrying amount does not exceed the carrying amount that would have been determined had no impairment loss been recognised for the asset (or a cash-generating unit) in prior years. A reversal of an impairment loss is recognised as income immediately, unless the relevant asset is carried at a revalued amount under another standard, in which case the reversal of the impairment loss is treated as a revaluation increase under that standard.

### 3. Significant Accounting Policies (Continued)

#### Financial instruments (continued)

##### Revenue recognition

Revenue is measured at the fair value of the consideration received or receivable and represents amounts receivable for properties sold and services provided in the normal course of business, net of discounts and sales related taxes.

##### **Sales of properties**

Revenue from sales of properties in the ordinary course of business is recognised when the respective properties have been completed and delivered to the buyers. Deposits and instalments received from purchasers prior to meeting the above criteria for revenue recognition are included in the consolidated statement of financial position under current liabilities.

When the completed properties are sold in exchange for dissimilar goods or services, the exchange is regarded as a transaction which generates revenue. The revenue is measured at the fair value of the goods or services received, adjusted by the amount of any cash or cash equivalents transferred.

##### **Agency fee, service income, management fee, parking fee and consultation fee**

Agency fee, service income, management fee, parking fee and consultation fee are recognised when services are provided.

##### **Contract revenue**

Contract revenue from installation contract is recognised when the outcome of the contract can be estimated reliably and the stage of completion at the end of reporting period can be measured reliably. Revenue from construction contracts is recognised on the percentage of completion method, measured by reference to the proportion that value of works performed to date relative to the estimated total revenue for each contract. When the outcome of a construction contract cannot be estimated reliably, revenue is recognised only to the extent of contract cost incurred that it is probable to be recoverable.

##### **Hotel operation**

Revenue from hotel accommodation, hotel management and related services, food and beverage sales and other ancillary services is recognised when the services are rendered.

##### **Interest income**

Interest income from a financial asset is recognised when it is probable that the economic benefits will flow to the Group and the amount of income can be measured reliably. Interest income is accrued on a time basis, by reference to the principal outstanding and at the effective interest rate applicable, which is the rate that exactly discounts estimated future cash receipts through the expected life of the financial asset to that asset's net carrying amount on initial recognition.

##### Government grants

Government grants are not recognised until there is reasonable assurance that the Group will comply with the conditions attaching to them and that the grants will be received.

Government grants are recognised in profit or loss on a systematic basis over the periods in which the Group recognises as expenses the related costs for which the grants are intended to compensate.

Government grants that are receivable as compensation for expenses or losses already incurred or for the purpose of giving immediate financial support to the Group with no future related costs are recognised in profit or loss in the period in which they become receivable.

##### Borrowing costs

Borrowing costs directly attributable to the acquisition, construction or production of qualifying assets, which are assets that necessarily take a substantial period of time to get ready for their intended use or sale, are added to the cost of those assets until such time as the assets are substantially ready for their intended use or sale.

All other borrowing costs are recognised in profit or loss in the period in which they are incurred.

##### Leasing

Leases are classified as finance leases whenever the terms of the lease transfer substantially all the risks and rewards of ownership to the lessee. All other leases are classified as operating leases.

# NOTES TO THE CONSOLIDATED FINANCIAL STATEMENTS

For the year ended 31 December 2012

## 3. Significant Accounting Policies (Continued)

Leasing (continued)

### **The Group as lessor**

Rental income from operating leases is recognised in profit or loss on a straight-line basis over the term of the relevant lease.

### **The Group as lessee**

Operating lease payments are recognised as an expense on a straight-line basis over the lease term, except where another systematic basis is more representative of the time pattern in which economic benefits from the leased asset are consumed.

In the event that lease incentives are received to enter into operating leases, such incentives are recognised as a liability. The aggregate benefit of incentives is recognised as a reduction of rental expense on a straight-line basis, except where another systematic basis is more representative of the time pattern in which economic benefits from the leased asset are consumed.

### **Leasehold land and building**

When a lease includes both land and building elements, the Group assesses the classification of each element as a finance or an operating lease separately based on the assessment as to whether substantially all the risks and rewards incidental to ownership of each element have been transferred to the Group, unless it is clear that both elements are operating leases in which case the entire lease is classified as an operating lease. Specifically, the minimum lease payments (including any lump-sum upfront payments) are allocated between the land and the building elements in proportion to the relative fair values of the leasehold interests in the land element and building element of the lease at the inception of the lease.

To the extent the allocation of the lease payments can be made reliably, interest in leasehold land that is accounted for as an operating lease is presented as "prepaid lease payments" in the consolidated statement of financial position and is amortised over the lease term on a straight-line basis except for those that are classified and accounted for as investment properties under the fair value model. When the lease payments cannot be allocated reliably between the land and building elements, the entire lease is generally classified as a finance lease and accounted for as property, plant and equipment.

### **Prepaid lease payments**

The prepaid lease payments represent upfront payments for land use rights for the purpose of development of properties for sale or for use in the production or supply of goods or services, and are initially recognised at cost and released to profit or loss over the remaining lease term on a straight-line basis. The prepaid lease payments in respect of development of projects for sale whereby the construction work is expected to complete beyond normal operating cycle are classified under non-current assets.

### **Premium on prepaid lease payments**

The premium on prepaid lease payments represent the excess of the consideration paid over the carrying amount of the prepaid lease payments in respect of leasehold lands in the PRC acquired through acquisition of subsidiaries and released to profit or loss over the remaining lease term on a straight-line basis. The premium on prepaid lease payments in respect of projects whereby the construction work is expected to complete beyond normal operating cycle are classified under non-current assets.

## Taxation

Income tax expense represents the sum of the tax currently payable and deferred tax.

The tax currently payable is based on taxable profit for the year. Taxable profit differs from the "profit before taxation" as reported in the consolidated statement of comprehensive income because it excludes items of income or expense that are taxable or deductible in other years and it further excludes items that are never taxable or deductible. The Group's liability for current tax is calculated using tax rates that have been enacted or substantively enacted by the end of the reporting period.

Deferred tax is recognised on differences between the carrying amounts of assets and liabilities in the consolidated financial statements and the corresponding tax base used in the computation of taxable profit. Deferred tax liabilities are generally recognised for all taxable temporary differences. Deferred tax assets are generally recognised to the extent that it is probable that taxable profits will be available against which those deductible temporary differences can be utilised. Such assets and liabilities are not recognised if the temporary difference arises from goodwill or from the initial recognition (other than in a business combination) of other assets and liabilities in a transaction that affects neither the taxable profit nor the accounting profit.

### 3. Significant Accounting Policies (Continued)

#### Taxation (continued)

Deferred tax liabilities are recognised for taxable temporary differences associated with investments in subsidiaries and associates, except where the Group is able to control the reversal of the temporary difference and it is probable that the temporary difference will not reverse in the foreseeable future. Deferred tax assets arising from deductible temporary differences associated with such investments are only recognised to the extent that it is probable that there will be sufficient taxable profits against which to utilise the benefits of the temporary differences and they are expected to reverse in the foreseeable future.

The carrying amount of deferred tax assets is reviewed at the end of the reporting period and reduced to the extent that it is no longer probable that sufficient taxable profits will be available to allow all or part of the asset to be recovered.

Deferred tax assets and liabilities are measured at the tax rates that are expected to apply in the period in which the liability is settled or the asset is realised, based on tax rate (and tax laws) that have been enacted or substantively enacted by the end of the reporting period.

The measurement of deferred tax liabilities and assets reflects the tax consequences that would follow from the manner in which the Group expects, at the end of the reporting period, to recover or settle the carrying amount of its assets and liabilities.

For the purposes of measuring deferred tax liabilities or deferred tax assets for investment properties that are measured using the fair value model, the carrying amounts of such properties are presumed to be recovered entirely through sale, unless the presumption is rebutted. The presumption is rebutted when the investment property is depreciable and is held within a business model whose objective is to consume substantially all of the economic benefits embodied in the investment property over time, rather than through sale. If the presumption is rebutted, deferred tax liabilities and deferred tax assets for such investment properties are measured in accordance with the above general principles set out in HKAS 12.

Current and deferred tax are recognised in profit or loss, except when it relates to items that are recognised in other comprehensive income or directly in equity, in which case, the current and deferred tax are also recognised in other comprehensive income or directly in equity respectively.

#### Retirement benefit costs

Payments to state-managed retirement benefit scheme and the Mandatory Provident Fund Scheme are recognised as an expense when employees have rendered service entitling them to the contributions.

#### Foreign currencies

In preparing the financial statements of each individual group entity, transactions in currencies other than the functional currency of the entity (foreign currencies) are recorded in the respective functional currency (i.e. the currency of the primary economic environment in which the entity operates) at the rates of exchange prevailing on the dates of transactions. At the end of the reporting period, monetary items denominated in foreign currencies are retranslated at the rates prevailing at that date. Non-monetary items that are measured in terms of historical cost in a foreign currency are not retranslated.

Exchange differences arising on the settlement of monetary items, and on the retranslation of monetary items, are included in profit or loss in the period in which they arise.

#### Share-based payment transactions

##### ***Equity-settled share-based payment transactions***

The fair value of services received determined by reference to the fair value of share options granted at the grant date is expensed on a straight-line basis over the vesting period, with a corresponding increase in equity (share options reserve).

At the end of the reporting period, the Group revises its estimates of the number of options that are expected to ultimately vest. The impact of the revision of the original estimates during the vesting period, if any, is recognised in profit or loss such that the cumulative expense reflects the revised estimate, with a corresponding adjustment to share options reserve.

When share options are exercised, the amount previously recognised in share options reserve will be transferred to share premium. When the share options are forfeited after the vesting date or are still not exercised at the expiry date, the amount previously recognised in share options reserve will continue to be held in share options reserve.

# NOTES TO THE CONSOLIDATED FINANCIAL STATEMENTS

For the year ended 31 December 2012

## 4. Critical Accounting Judgments and Key Sources of Estimation Uncertainty

In the application of the Group's accounting policies, which are described in note 3, the directors of the Company are required to make judgments, estimates and assumptions about the carrying amounts of assets and liabilities that are not readily apparent from other sources. The estimates and associated assumptions are based on historical experience and other factors that are considered to be relevant. Actual results may differ from these estimates.

The estimates and underlying assumptions are reviewed on an on-going basis. Revisions to accounting estimates are recognised in the period in which the estimate is revised if the revision affects only that period, or in the period of the revision and future periods if the revision affects both current and future periods.

### Critical judgments in applying accounting policies

The following is the critical judgments, apart from those involving estimations (see below), that the directors have made in the process of applying the Group's accounting policies and that have the most significant effect on the amounts recognised in the consolidated financial statements.

### Deferred taxation on investment properties

For the purposes of measuring deferred taxes arising from investment properties that are measured using the fair value model, the directors have reviewed the Group's investment property portfolios and concluded that the Group's investment properties are not held under a business model whose objective is to consume substantially all of the economic benefits embodied in the investment properties over time. Therefore, in measuring the Group's deferred taxation on investment properties, the directors have determined that the presumption that the carrying amounts of investment properties measured using the fair value model are recovered entirely through sale is not rebutted.

As a result, the Group has recognised the related deferred taxes on changes in fair value of investment properties taking into account the land appreciation tax and PRC enterprise income tax payable on disposal of its investment properties.

The following are the key assumptions concerning the future, and other key sources of estimation uncertainty at the end of reporting period, that have a significant risk of causing a material adjustment to the carrying amounts of assets and liabilities within the next financial year.

### Determination of net realisable value of properties under development for sale and completed properties for sale

Properties under development for sale and completed properties for sale are stated at the lower of cost and net realisable value with aggregate carrying amount of approximately RMB11,372,628,000 (2011: RMB10,222,320,000). Cost of each unit in each phase of development is determined using the weighted average method. The net realisable value is the estimated selling price less estimated selling expenses and estimated cost of completion (if any), which are determined based on best available information. Where there is any decrease in the estimated selling price arising from any changes to the property market conditions in the PRC, there may be write-down on the properties under development for sale and completed properties for sale.

### LAT

The Group is subject to land appreciation tax in the PRC. However, the implementation and settlement of the tax varies amongst different tax jurisdictions in various cities of the PRC and certain projects of the Group have not finalised their land appreciation tax calculations and payments with any local tax authorities in the PRC. Accordingly, significant estimate is required in determining the amount of land appreciation and its related income tax provisions. The Group recognised the land appreciation tax based on management's best estimates. The final tax outcome could be different from the amounts that were initially recorded, and these differences will impact the income tax expense and the related income tax provisions in the periods in which such tax is finalised with local tax authorities.

### Deferred tax assets

Deferred tax assets are recognised for all unused tax losses to the extent that it is probable that taxable profit or taxable temporary difference will be available against which the losses can be utilised. Significant management estimation is required to determine the amount of deferred tax assets that can be recognised, based upon the likely timing and level of future taxable profits or taxable temporary difference together with future tax planning strategies.

### Recognition and allocation of construction costs on properties under development

Development costs of properties are recorded as properties under development during the construction stage and will be transferred to completed properties for sale and charged to the consolidated statement of comprehensive income upon the recognition of the sales of the properties. Before the final settlement of the development costs and other costs relating to the sale of the properties, these costs are accrued by the Group based on management's best estimate. During the development stage, the Group typically divides the development projects into phases. Costs that are common to different phases are allocated to individual phases based on saleable area. Where the final settlement of costs and the related cost allocation is different from the initial estimates, any increase or decrease in the development costs and other costs would affect the profit or loss in future years.



#### 4. Critical Accounting Judgments and Key Sources of Estimation Uncertainty (continued)

##### Estimated impairment of trade receivables

When there is objective evidence of impairment loss, the Group takes into consideration the estimation of future cash flows. The amount of the impairment loss is measured as the difference between the asset's carrying amount and the present value of estimated future cash flows (excluding future credit losses that have not been incurred) discounted at the financial asset's original effective interest rate (i.e. the effective interest rate computed at initial recognition). Where the actual future cash flows are less than expected, a material impairment loss may arise. As at 31 December 2012, the carrying amount of trade receivable is RMB964,674,000 (2011: carrying amount of RMB410,171,000).

##### Estimated impairment of goodwill

Determining whether goodwill is impaired requires an estimation of the value in use of the cash-generating units to which goodwill has been allocated. The value in use calculation requires the Group to estimate the future cash flows expected to arise from the cash-generating unit and a suitable discount rate in order to calculate the present value. Where the actual future cash flows are less than expected, a material impairment loss may arise. As at 31 December 2012, the carrying amount of goodwill net of accumulated impairment loss was approximately RMB16,488,000.

#### 5. Capital Risk Management

The Group manages its capital to ensure that entities in the Group will be able to continue as a going concern while maximising the return to shareholders through the optimisation of the debt and equity balance. The Group's overall strategy remains unchanged from prior year. The capital structure of the Group consists of net debt, which includes amounts due to related parties as disclosed in note 36, borrowings as disclosed in note 37, senior notes as disclosed in note 38, cash and cash equivalents as disclosed in note 34 and equity attributable to owners of the Company, comprising share capital and reserves.

The directors of the Company review the capital structure periodically. As a part of this review, the corporate finance department reviews the planned construction projects proposed by engineering department and prepares the annual budget taking into account of the provision of funding.

The directors of the Company then assess the annual budget and consider the cost of capital and the risks associated with each class of capital. The directors of the Company also balance its overall capital structure through the payment of dividends, new share issues as well as the issue of new debt or the redemption of existing debt.

#### 6. Financial Instruments

##### (a) Categories of financial instruments

	31 December 2012 RMB'000	31 December 2011 RMB'000
<b>Financial assets</b>		
Loans and receivables (including cash and cash equivalents)	4,702,811	2,530,510
Financial assets at FVTPL	42,200	–
<b>Financial liabilities</b>		
Amortised cost	10,309,378	7,655,232

##### (b) Financial risk management objectives and policies

The Group's major financial instruments include financial assets at fair value through profit or loss, advance to an associate, deposits paid for acquisition of land use rights, subsidiaries and a property project, trade and other receivables, amounts due from related parties, restricted bank deposits, bank balances and cash, trade and other payables, amounts due to related parties, borrowings and senior notes. Details of these financial instruments are disclosed in respective notes.

The management monitors and manages the financial risks relating to the operations of the Group through internal risk assessment which analyses exposures by degree and magnitude of risks. The risks included market risk (including currency risk and interest rate risk), credit risk and liquidity risk. The policies on how to mitigate these risks are set out below. The management manages and monitors these exposures to ensure appropriate measures are implemented on a timely and effective manner.

## NOTES TO THE CONSOLIDATED FINANCIAL STATEMENTS

For the year ended 31 December 2012

### 6. Financial Instruments (continued)

#### (c) Foreign currency risk management

The Group has bank balances, borrowings and senior notes which are denominated in foreign currencies of the relevant group entities, hence is exposed to exchange rate fluctuations.

The carrying amount of the Group's foreign currency denominated monetary assets and monetary liabilities at the respective reporting periods are as follow:

	31 December 2012 RMB'000	31 December 2011 RMB'000
<b>Assets</b>		
United States Dollars ("USD")	1,030,061	5,195
Hong Kong Dollars ("HKD")	60,681	288,798
Taiwan Dollars ("TWD")	1,693	3,496
Japanese Yen ("JPY")	8	–
<b>Liabilities</b>		
USD	3,245,589	1,596,688
HKD	137,841	163,761

The Group currently does not enter into any derivative contracts to minimise the currency risk exposure. However, the management will consider hedging significant currency risk should the need arise.

The Group mainly exposes to the effects of fluctuation in USD and HKD against RMB.

The following table details the Group's sensitivity to a 5% (2011: 5%) increase and decrease in the RMB against the relevant foreign currencies. 5% (2011: 5%) is the sensitivity rate used in management's assessment of the reasonably possible change in foreign exchange rates. The sensitivity analysis includes only outstanding foreign currency denominated monetary items and adjusts their translation at the year end for a 5% (2011: 5%) change in foreign currency rates. The sensitivity analysis includes bank balances, borrowings and senior notes. A positive number indicates an increase in profit for the year where the RMB strengthens against the relevant currencies. For a 5% (2011: 5%) weakening of the RMB against the relevant currencies, there would be an equal and opposite impact on the profit for the year.

	2012 RMB'000	2011 RMB'000
<b>USD</b>		
Increase in profit for the year	110,776	79,575
<b>HKD</b>		
Increase (decrease) in profit for the year	3,858	(6,252)
<b>TWD</b>		
Decrease in profit for the year	(85)	(175)

During the year ended 31 December 2012, in management's opinion, the sensitivity analysis is unrepresentative of the foreign exchange risk as the year end exposure does not reflect the exposure during the year. USD denominated borrowings and HKD denominated bank balances were incurred in the last quarter of the 2011 and 2012 financial year, which results in an increment in the respective balances at year end.

## 6. Financial Instruments (continued)

### (d) Interest rate risk management

The Group is exposed to cash flow interest rate risk due to the fluctuation of the prevailing market interest rate on bank balances and variable-rate borrowings.

The Group is also exposed to fair value interest rate risk which relates primarily to its fixed-rate borrowings and senior notes (see notes 37 and 38). The Group currently does not use any derivative contracts to hedge its loans to interest rate risk. However, the management will consider hedging significant interest rate exposure should the need arise.

The Group's exposures to interest rates on financial liabilities are detailed in the liquidity risk management section of this note. The Group's cash flow interest rate risk is mainly concentrated on the fluctuation of the London Interbank Offered Rate ("LIBOR") arising from the Group's USD borrowings, the Hong Kong Interbank Offer Rate ("HIBOR") arising from the Group's HKD borrowings and Benchmark Borrowing Rate of The People's Bank of China ("Benchmark Rate") from the Group's RMB borrowings.

#### **Sensitivity analysis**

##### *Bank balances and restricted bank deposits*

The sensitivity analysis below has been determined based on the exposure to interest rates for the bank balances and restricted bank deposits at the end of the reporting period. A 25 basis points (2011: 25 basis points) increase or decrease is used and represents management's assessment of the reasonably possible change in interest rates.

If interest rates had been higher/lower by 25 basis points (2011: 25 basis points) and all other variables were held constant, the Group's profit for the year ended 31 December 2012 would increase/decrease by approximately RMB6,554,000 (2011: increase/decrease of approximately RMB2,506,000).

##### *Variable-rate borrowings*

The sensitivity analysis below has been determined based on the exposure to interest rates for the variable-rate borrowings at the end of the reporting period. A 50 basis points (2011: 50 basis points) increase or decrease is used and represents management's assessment of the reasonably possible change in interest rates.

If interest rates had been higher/lower by 50 basis points (2011: 50 basis points) and all other variables were held constant, the Group's profit for the year ended 31 December 2012 would decrease/increase by approximately RMB3,811,000 (2011: decrease/increase of approximately RMB5,036,000), net of interest that would be capitalised or not capitalised in accordance with the Group's accounting policy.

### (e) Credit risk management

As at 31 December 2012, the Group's maximum exposure to credit risk which will cause a financial loss to the Group due to failure to discharge an obligation by the counterparties and financial guarantees provided by the Group is arising from:

- the carrying amount of the respective recognised financial assets as stated in the consolidated statement of financial position; and
- the amount of contingent liabilities in relation to financial guarantee issued by the Group as disclosed in note 46.

In order to minimise the credit risk, the Group has policies in place for determination of credit limits, credit approvals and other monitoring procedures to ensure that follow-up action is taken to recover overdue debts. In addition, the Group reviews the recoverable amount of each individual trade debt at the end of the reporting period to ensure that adequate impairment losses are made for irrecoverable amounts. In this regard, the directors of the Company consider that the Group's credit risk is significantly reduced.

The Group has no significant concentration of credit risk on trade receivables, with exposure spread over a number of counterparties and customers.

## NOTES TO THE CONSOLIDATED FINANCIAL STATEMENTS

For the year ended 31 December 2012

### 6. Financial Instruments (continued)

#### (e) Credit risk management (continued)

At 31 December 2012, the Group has concentration of credit risk on the deposits for acquisition of a property project, land use rights and subsidiaries paid to counterparties which are all engaged in PRC property development business and property operation service.

The Group's credit risk on liquid funds is limited because the counterparties are banks with high credit ratings and good reputation established in the PRC and Hong Kong. The Group's credit risk on deposits paid on acquisition of a property project, land use rights and subsidiaries are not significant as the counterparties are enterprises with good reputation established in PRC.

For properties under development which are subject to pre-sales agreements, the Group typically provides guarantees to banks in connection with the customers' borrowing of mortgage loans to finance their purchase of the properties for an amount up to 70% of the total purchase price of the property. If a purchaser defaults on the payment of its mortgage during the term of guarantee, the bank holding the mortgage may demand the Group to repay the outstanding amount of the loan and any accrued interest thereon. Under such circumstances, the Group is able to retain the customer's purchase deposit and sell the property to recover any amounts paid by the Group to the bank. In this regard, the directors of the Company consider that the Group's credit risk is significantly reduced.

#### (f) Liquidity risk management

In the management of the liquidity risk, the Group monitors and maintains a level of cash and cash equivalents deemed adequate by the management to finance the Group's operations and mitigate the effects of fluctuations in cash flows. The management monitors the utilisation of borrowings and ensures compliance with loan covenants.

The Group relies on borrowings, amounts due to related parties and senior notes as a significant source of liquidity. As at 31 December 2012, the Group has total available unutilised overdraft and bank loan facilities of approximately RMB408,154,000 (2011: RMB478,000,000).

The following table details the Group's remaining contractual maturity for its non-derivative financial liabilities. The table has been drawn up based on the undiscounted cash flows of financial liabilities based on the earliest date on which the Group can be required to pay. Specifically, bank loans with a repayment on demand clause are included in the earliest time band regardless of the probability of the banks choosing to exercise their rights. The maturity dates for other non-derivative financial liabilities are based on the agreed repayment dates.

## 6. Financial Instruments (continued)

### (f) Liquidity risk management (continued)

The table includes both interest and principal cash flows. To the extent that interest flows are floating rate, the undiscounted amount is derived from interest rate at the end of the reporting period.

#### Liquidity table

	Weighted average effective interest rate %	On demand or less than 1 month RMB'000	1-3 months RMB'000	3 months to 1 year RMB'000	1-5 years RMB'000	Over 5 years RMB'000	Total undiscounted cash flows RMB'000	Carrying amount RMB'000
<b>As at 31 December 2012</b>								
<b>Non-derivative financial liabilities</b>								
Trade and other payables	–	713,833	385,021	1,275,584	51,957	–	2,426,395	2,426,395
Amounts due to related parties	–	1,573	–	–	–	–	1,573	1,573
Borrowings								
– fixed rate	13.6	6,695	13,390	439,808	200,361	–	660,254	592,000
– variable rate	7.0	434,449	200,743	1,411,460	3,369,179	153,386	5,569,217	4,960,407
Financial guarantee contracts	–	2,750,751	–	–	–	–	2,750,751	–
Senior notes	14.9	–	108,032	213,628	3,348,286	–	3,669,946	2,329,003
		3,907,301	707,186	3,340,480	6,969,783	153,386	15,078,136	10,309,378
<b>As at 31 December 2011</b>								
<b>Non-derivative financial liabilities</b>								
Trade and other payables	–	786,674	389,199	949,438	34,005	–	2,159,316	2,159,316
Amounts due to related parties	–	2,547	–	–	–	–	2,547	2,547
Borrowings								
– fixed rate	–	–	–	–	–	–	–	–
– variable rate	6.7	238,280	46,333	1,862,997	2,544,013	799,036	5,490,659	4,741,002
Financial guarantee contracts	–	2,478,814	–	–	–	–	2,478,814	–
Senior notes	14.9	–	–	105,855	1,020,746	–	1,126,601	752,367
		3,506,315	435,532	2,918,290	3,598,764	799,036	11,257,937	7,655,232

Bank loans with a repayment on demand clause are included in the “on demand or less than 1 month” time band in the above maturity analysis. As at 31 December 2012, the aggregate undiscounted principal amounts of these bank loans amounted to approximately RMB591,641,000 (2011: RMB203,761,000). Taking into account the Group’s financial position, the directors do not believe that it is probable that the banks will exercise their discretionary rights to demand immediate repayment. The directors believe that such bank loans will be repaid ranging from 1 year to 3 years after the reporting date in accordance with the scheduled repayment dates set out in the loan agreements. At that time, the aggregate principal and interest cash outflows will amount to RMB665,539,000 (2011: RMB221,662,000).

The amounts included above for financial guarantee contracts are the maximum amounts the Group could be required to settle under the arrangement for the full guaranteed amount if that amount is claimed by the counterparty to the guarantee. Based on expectations at the end of the reporting period, the Group considers that it is more likely than not that no amount will be payable under the arrangement. However, this estimate is subject to change depending on the probability of the counterparty claiming under the guarantee which is a function of the likelihood that the financial receivables held by the counterparty which are guaranteed suffer credit losses.

The amounts included above for variable interest rate instruments for non-derivative financial liabilities is subject to change if changes in variable interest rates differ to those estimates of interest rates determined at the end of the reporting period.

# NOTES TO THE CONSOLIDATED FINANCIAL STATEMENTS

For the year ended 31 December 2012

## 6. Financial Instruments (continued)

### (g) Fair value

The fair values of financial assets and financial liabilities are determined in accordance with generally accepted pricing models based on discounted cash flow analysis.

Except for the senior notes set out in note 38, the directors consider that the carrying amounts of financial assets and financial liabilities recorded at amortised costs in the consolidated financial statements approximate their fair values.

#### ***Fair value measurements recognised in the consolidated statement of financial position***

The following table provides an analysis of financial instruments that are measured subsequent to initial recognition at fair value, grouped into Levels 1 to 3 based on the degree to which the fair value is observable.

- Level 1 fair value measurements are those derived from quoted prices (unadjusted) in active market for identical assets or liabilities.
- Level 2 fair value measurements are those derived from inputs other than quoted prices included within Level 1 that are observable for the asset or liability, either directly (i.e. as prices) or indirectly (i.e. derived from prices).
- Level 3 fair value measurements are those derived from valuation techniques that include inputs for the asset or liability that are not based on observable market data (unobservable inputs).

#### ***Financial assets at FVTPL***

	Level 2	
	2012	2011
	RMB'000	RMB'000
Structured deposits	42,200	–

## 7. Revenue and Segment Information

	2012 RMB'000	2011 RMB'000
Sales of properties (Note)	5,885,314	5,396,289
Rental income from investment properties	90,266	37,887
Agency fee from provision of property agency services	14,470	10,571
Management fee and installation services fee from provision of property operation services	184,683	124,895
Hotel operations	55,317	22,708
	6,230,050	5,592,350

Note: The properties sold by the Group are mainly represented by residential and commercial properties.

The segment information reported externally was analysed on the basis of the different products and services supplied by the Group's operating divisions which is consistent with the internal information that are regularly reviewed by the directors of the Company, the chief operating decision maker, for the purposes of resource allocation and assessment of performance. This is also the basis of organisation in the Group, whereby the management has chosen to organise the Group around differences in products and services. No operating segments identified by the chief operating decision maker have been aggregated in arriving at the reportable segments of the Group.

Inter-segment revenue are eliminated on consolidation.

The Group has five reportable and operating segments as follows:

Property development	–	developing and selling of properties in the PRC
Property investment	–	leasing of investment properties
Property agency services	–	provision of property agency and other related services
Property operation services	–	provision of property management, installation of security systems and other related services
Hotel operations	–	provision of hotel accommodation, hotel management and related services, food and beverage sales and other ancillary services

The accounting policies of the operating segments are the same as the Group's accounting policies described in note 3. Segment profit represents the profit earned by each segment without allocation of central administration costs and directors' salaries, interest income, imputed interest income on non-current interest-free advance to an associate, exchange gain, share of results of associates, gain on disposal of an associate, finance costs and income tax expense. This is the measure reported to the chief operating decision maker for the purposes of resources allocation and assessment of segment performance.

For the purposes of monitoring segment performance and allocating resources between segments, the chief operating decision maker also reviews the segment assets attributable to each operating segment, which comprises assets other than interests in associates and jointly controlled entity, financial assets at fair value through profit or loss, advance to an associate, restricted bank deposits, bank balances and cash and other corporate assets.

## NOTES TO THE CONSOLIDATED FINANCIAL STATEMENTS

For the year ended 31 December 2012

### 7. Revenue and Segment Information (continued)

The following is an analysis of the Group's revenue, results and other material items by reportable and operating segment under review:

Segment revenues, results, assets and other material items for 31 December 2012:

	Property development RMB'000	Property investment RMB'000	Property agency services RMB'000	Property operation services RMB'000	Hotel operations RMB'000	Total RMB'000
External revenues	5,885,314	90,266	14,470	184,683	55,317	6,230,050
Inter-segment revenues	52,388	1,643	1,157	286,021	–	341,209
Segment result	2,205,017	294,225	8,109	108,853	(53,756)	2,562,448
Segment assets	16,279,343	3,422,232	8,359	415,056	432,359	20,557,349
Amounts included in the measure of segment profit or loss or segment assets:						
Additions to non-current assets (note)	34,723	154,868	–	25,714	98,368	313,673
Change in fair value of investment properties	–	167,876	–	–	–	167,876
Recognition of change in fair value of completed properties for sale upon transfer to investment properties	330,257	–	–	–	–	330,257
Release of prepaid lease payments	7,454	–	–	–	4,648	12,102
Release of premium on prepaid lease payments	11,133	–	–	–	–	11,133
Depreciation of property, plant and equipment	18,421	–	1	2,862	16,077	37,361
Loss on disposal of property, plant and equipment	31	–	–	–	–	31
Allowance (reversal) on bad and doubtful debts, net	11,012	–	–	(465)	–	10,547

Inter-segment revenues are charged at prevailing market rate.



## 7. Revenue and Segment Information (continued)

Segment revenues, results, assets and other material items for 31 December 2011:

	Property development RMB'000	Property investment RMB'000	Property agency services RMB'000	Property operation services RMB'000	Hotel operations RMB'000	Total RMB'000
External revenues	5,396,289	37,887	10,571	124,895	22,708	5,592,350
Inter-segment revenues	3,617	1,835	7,430	158,781	–	171,663
Segment result	2,008,475	231,581	42,396	68,366	(39,869)	2,310,949
Segment assets	13,319,848	2,445,142	2,011	302,290	422,111	16,491,402
Amounts included in the measure of segment profit or loss or segment assets:						
Additions to non-current assets (note)	51,822	278,636	144	8,185	153,284	492,071
Change in fair value of investment properties	–	182,980	–	–	–	182,980
Recognition of change in fair value of completed properties for sale upon transfer to investment properties	191,142	–	–	–	–	191,142
Release of prepaid lease payments	4,736	–	–	–	88	4,824
Release of premium on prepaid lease payments	6,864	–	–	–	–	6,864
Depreciation of property, plant and equipment	7,771	–	338	2,450	10,687	21,246
Loss (gain) on disposal of property, plant and equipment	33	–	–	(25)	(13)	(5)
(Reversal) allowance on bad and doubtful debts, net	(2,334)	–	–	2,069	–	(265)

Inter-segment revenues are charged at prevailing market rate.

Note: Additions to non-current assets comprise mainly additions to goodwill, property, plant and equipment and investment properties and exclude interests in associates, prepayments, deposits paid for acquisition of subsidiaries and a property project and deferred tax assets.

## NOTES TO THE CONSOLIDATED FINANCIAL STATEMENTS

For the year ended 31 December 2012

### 7. Revenue and Segment Information (continued)

Reconciliation:

	2012 RMB'000	2011 RMB'000
<b>Revenue:</b>		
Total revenue for reportable segments	6,571,259	5,764,013
Elimination of inter-segment revenues	(341,209)	(171,663)
<b>Group's total revenues</b>	<b>6,230,050</b>	<b>5,592,350</b>
<b>Profit or loss:</b>		
Total segment results	2,562,448	2,310,949
Elimination of inter-segment result	(67,278)	(50,728)
Unallocated amounts:		
Unallocated income	17,945	38,053
Unallocated corporate expenses	(68,976)	(40,346)
Finance costs	(57,698)	(108,471)
Impairment loss recognised in respect of goodwill	–	(1,321)
Share of results of associates	417	171
Gain on disposal of an associate	–	3,533
<b>Profit before taxation</b>	<b>2,386,858</b>	<b>2,151,840</b>

Reconciliation:

	2012 RMB'000	2011 RMB'000
<b>Assets:</b>		
Total assets for reportable segments	20,557,349	16,491,402
Unallocated assets:		
Interests in associates	1,171	1,077
Interest in a jointly controlled entity	19,720	–
Financial assets at fair value through profit or loss	42,200	–
Restricted bank deposits	707,614	315,134
Bank balances and cash	2,788,106	1,021,355
Corporate assets	410,437	293,668
<b>Group's total assets</b>	<b>24,526,597</b>	<b>18,122,636</b>

## 7. Revenue and Segment Information (continued)

	2012 RMB'000	2011 RMB'000
<b>Other material items:</b>		
<i>Release of prepaid lease payments</i>		
Reportable segment and Group's totals	12,102	4,824
<i>Release of premium on prepaid lease payments</i>		
Reportable segment and Group's totals	11,133	6,864
<i>Depreciation of property, plant and equipment</i>		
Reportable segment totals	37,361	21,246
Unallocated amount	117	228
Group's total	37,478	21,474
<i>Additions to non-current assets</i>		
Reportable segment totals	313,673	492,071
Unallocated amount	–	568
Group's total	313,673	492,639
<i>Loss (gain) on disposal of property, plant and equipment</i>		
Reportable segment and Group's totals	31	(5)
<i>Allowance (reversal) on bad and doubtful debt, net</i>		
Reportable segment and Group's totals	10,547	(265)
<i>Impairment loss recognised in respect of goodwill</i>		
Reportable segment and Group's totals	–	1,321

The Group's revenue from external customers is derived solely from its operations in the PRC, and non-current assets of the Group are mainly located in the PRC.

During the years ended 31 December 2012 and 2011, there was no revenue from transactions with a single external customer amounted to 10% or more of the Group's total revenue.

## 8. Other Income, Gains and Losses

	2012 RMB'000	2011 RMB'000
Interest income	10,424	8,941
Imputed interest income on non-current interest-free advance to an associate	–	537
Forfeiture income on deposits received	853	1,148
Government grant (note)	8,505	5,797
Net exchange gain	7,483	28,573
Others	4,535	1,926
	31,800	46,922

Note: The amount represents the grants received from the relevant PRC government to encourage the development of real estate industry. The subsidies are unconditional and granted on a discretionary basis to the Group during the year.

## NOTES TO THE CONSOLIDATED FINANCIAL STATEMENTS

For the year ended 31 December 2012

### 9. Finance Costs

	2012 RMB'000	2011 RMB'000
Interest on:		
– borrowings wholly repayable within five years	393,156	294,931
– borrowings not wholly repayable within five years	10,715	30,247
– senior notes (note 38)	169,161	75,029
– amounts due to related parties	–	1,744
Less: Amount capitalised in properties under development for sale	(381,978)	(256,522)
Amount capitalised in land development expenditure	(120,570)	(32,039)
Amount capitalised in investment properties under development	(4,951)	(4,663)
Amount capitalised in construction in progress	(7,835)	(256)
	57,698	108,471

In 2012, certain amount of borrowing costs capitalised arose on the general borrowing pool and were calculated by applying the capitalisation rate of 9.6% per annum to expenditure on qualifying assets.

### 10. Profit before Taxation

	2012 RMB'000	2011 RMB'000
Profit before taxation has been arrived at after charging (crediting):		
Directors' emoluments (note 12)	9,800	8,617
Other staff's salaries and allowances	208,861	218,619
Retirement benefit scheme contributions	19,930	22,052
Share-based payments	3,378	1,578
Total staff costs	241,969	250,866
Less: Amount capitalised in properties under development for sale	(85,566)	(67,475)
Amount capitalised in land development expenditure	(4,021)	–
Amount capitalised in investment properties under development	(1,152)	–
	151,230	183,391
Auditor's remuneration	4,165	4,069
Release of prepaid lease payments	12,102	4,824
Release of premium on prepaid lease payments	11,133	6,864
Depreciation of property, plant and equipment	37,478	21,474
Loss (gain) on disposal of property, plant and equipment	31	(5)
Allowance (reversal) on bad and doubtful debts, net	10,547	(265)
Cost of properties sold recognised as an expense	3,420,029	2,771,307
Contract cost recognised as an expense	29,695	39,318
Rental expenses in respect of rented premises under operating leases	6,994	7,688
Gross rental income from investment properties	(90,266)	(37,887)
Less: direct operating expenses from investment properties that generated rental income	7,139	3,658
	(83,127)	(34,229)

## 11. Income Tax Expense

	2012 RMB'000	2011 RMB'000 (restated)
Current tax:		
PRC taxes		
EIT	541,120	520,569
LAT	580,082	403,675
	1,121,202	924,244
Deferred tax (note 28)		
Current year	140,007	114,913
Underprovision of deferred tax assets	–	(813)
	140,007	114,100
	1,261,209	1,038,344

No provision for Hong Kong Profits Tax has been made in the consolidated financial statements as the income of the Group neither arises in nor is derived from Hong Kong.

The Group's PRC enterprise income tax is calculated based on the applicable tax rate on assessable profits, if applicable.

PRC land appreciation tax is levied at progressive rates ranging from 30% to 60% on the appreciation of land value, being the proceeds of sales of properties less deductible expenditures including cost of land use rights and all property development expenditures.

The income tax expense for the year can be reconciled to the profit before taxation per the consolidated statement of comprehensive income as follows:

	2012 RMB'000	2011 RMB'000 (restated)
Profit before taxation	2,386,858	2,151,840
Tax at PRC enterprise income tax rate of 25% (2011: 25%) (note i)	596,715	537,960
Tax effect of share of results of associates	(104)	(43)
Tax effect of income not taxable for tax purposes	(2,539)	(1,131)
Tax effect of expenses not deductible for tax purposes (note ii)	57,122	58,271
Tax effect of tax losses not recognised	53,572	60,575
Utilisation of tax losses previously not recognised	(2,116)	(5,858)
Tax effect of different tax rates of subsidiaries	(8,211)	(9,518)
LAT	580,082	403,675
Tax effect of LAT	(145,021)	(100,919)
Underprovision of deferred tax assets	–	(813)
Others (note iii)	131,709	96,145
Income tax expense for the year	1,261,209	1,038,344

Notes:

- (i) Majority of the assessable profits of the Group were derived from subsidiaries situated in Shenzhen and Chengdu of the PRC and the applicable enterprise income tax rate of those subsidiaries is 25%.
- (ii) The amounts for the years ended 31 December 2012 and 2011 mainly relate to the tax effect of expenses incurred by offshore companies, including the interest on senior notes and professional fees.
- (iii) The amounts for the years ended 31 December 2012 and 2011 represent the deferred taxes of LAT payable on changes in fair value of the Group's investment properties in the PRC upon sales of those investment properties.

# NOTES TO THE CONSOLIDATED FINANCIAL STATEMENTS

For the year ended 31 December 2012

## 12. Directors', Chief Executive's and Employees' Remuneration

The emoluments of the directors and the chief executive on a named basis are as follows:

	Fees RMB'000	Salaries and other benefits RMB'000	Discretionary bonus RMB'000 (note v)	Retirement benefit scheme contributions RMB'000	Share-based payments RMB'000	Total RMB'000
<b>For the year ended 31 December 2012</b>						
<i>Executive directors:</i>						
Pan Jun (潘軍) (note i)	–	1,984	–	43	448	2,475
Zeng Jie (曾寶寶)	–	1,984	–	43	448	2,475
Feng Huiming (馮輝明) (note ii)	–	772	–	43	270	1,085
Lam Kam Tong (林錦堂) (note iii)	–	702	514	6	51	1,273
Chan Sze Hon (陳思翰) (note iv)	–	938	–	9	297	1,244
<i>Independent non-executive directors:</i>						
He Min (何敏)	240	–	–	–	72	312
Huang Ming (黃明)	240	–	–	–	72	312
Liao Changjiang (廖長江)	240	–	–	–	72	312
Xu Quan (許權)	240	–	–	–	72	312
	960	6,380	514	144	1,802	9,800
<b>For the year ended 31 December 2011</b>						
<i>Executive directors:</i>						
Pan Jun (潘軍)	–	1,802	–	37	150	1,989
Zeng Jie (曾寶寶)	–	1,802	–	37	150	1,989
Feng Huiming (馮輝明)	–	1,003	656	37	151	1,847
Chan Sze Hon (陳思翰)	–	1,010	602	9	115	1,736
<i>Independent non-executive directors:</i>						
He Min (何敏)	240	–	–	–	24	264
Huang Ming (黃明)	240	–	–	–	24	264
Liao Changjiang (廖長江)	240	–	–	–	24	264
Xu Quan (許權)	240	–	–	–	24	264
	960	5,617	1,258	120	662	8,617

Notes:

- (i) Mr Pan Jun is also the Chief Executive of the Company and his emoluments disclosed above include those for services rendered by him as the Chief Executive.
- (ii) Resigned on 3 September 2012
- (iii) Appointed on 28 May 2012
- (iv) Resigned on 30 November 2012
- (v) The discretionary bonus is determined by the board of directors based on the Group's performance for each financial year.

## 12. Directors' Chief Executive's and Employees' Remuneration (continued)

### Employees' emoluments

The five individuals with the highest emoluments in the Group included 2 (2011: 2) directors for both years. Details of their emoluments are set out above. The emoluments of the remaining 3 (2011: 3) of the five highest paid individuals are as follows:

	2012 RMB'000	2011 RMB'000
Salaries and allowances	3,265	2,198
Discretionary bonus	1,133	4,003
Retirement benefit scheme contributions	128	109
Share-based payments	734	185
	5,260	6,495

Their emoluments were within the following band:

	2012 No. of employees	2011 No. of employees
HK\$1,500,001 to HK\$2,000,000	1	–
HK\$2,000,001 to HK\$3,000,000	2	2
HK\$3,000,001 to HK\$3,500,000	–	1

During the years ended 31 December 2012 and 2011, no remuneration was paid by the Group to any of the directors and Chief Executive or the five highest paid individuals as an inducement to join or upon joining the Group or as compensation for loss of office. None of the directors and Chief Executive waived any remuneration for the years ended 31 December 2012 and 2011.

## 13. Dividends

	2012 RMB'000	2011 RMB'000
Final dividend for the financial year ended 31 December 2011 of HK4.00 cents per share (2011: final dividends for the financial year ended 31 December 2010 of HK4.00 cents) (Note i)	168,859	165,888
Dividends paid to non-controlling shareholders (Note ii)	–	8,722

Notes:

- (i) Subsequent to the end of the reporting period, a final dividend for the financial year ended 31 December 2012 of HK5.50 cents, equivalent to RMB4.46) (2011: final dividend for the financial year ended 31 December 2011 of HK4.00 cents, equivalent to RMB3.24 cents) per share amounting to HK286,397,196, equivalent to RMB231,981,721, in aggregate has been proposed by the directors for approval by the shareholders in the annual general meeting. The final dividends proposed after the end of the reporting period has not been recognised as a liability at the end of the reporting period.
- (ii) The amount represents dividends paid by the PRC subsidiaries to their non-controlling shareholders.

## NOTES TO THE CONSOLIDATED FINANCIAL STATEMENTS

For the year ended 31 December 2012

### 14. Earnings Per Share

The calculation of the basic and diluted earnings per share attributable to the owners of the Company is based on the following data:

	2012 RMB'000	2011 RMB'000 (restated)
<b>Earnings</b>		
Earnings for the purpose of basic and diluted earnings per share (Profit for the year attributable to owners of the Company)	1,139,241	1,057,479
	2012	2011
<b>Number of shares</b>		
Weighted average number of ordinary shares for the purpose of basic earnings per share	5,207,221,750	5,041,481,175
Effect of dilutive potential ordinary shares Share options	2,790,310	–
Weighted average number of ordinary shares for the purpose of diluted earnings per share	5,210,012,060	5,041,481,175

The weighted average number of ordinary shares during the year ended 31 December 2011 has been adjusted for the effect of the subscription shares as set out in note 39.

No adjustment for diluted earnings per share is presented as share option granted by the Company as the exercise prices are higher than the average market price of the Company's shares during the year ended 31 December 2011.

### 15. Property, Plant And Equipment

	Hotel buildings RMB'000	Buildings RMB'000	Renovations and leasehold improvements RMB'000	Furniture, fixtures and equipment RMB'000	Motor vehicles RMB'000	Construction in progress RMB'000	Total RMB'000
<b>COST</b>							
At 1 January 2011	54,489	39,775	25,562	38,124	19,066	243,252	420,268
Transfer from completed properties for sale (Note i)	44,906	–	–	–	–	–	44,906
Transfer from properties under development for sale (Note ii)	–	–	–	–	–	11,270	11,270
Acquisition of business (note 40(b))	–	–	–	18	–	–	18
Additions	–	4,312	657	23,474	4,561	124,805	157,809
Transfer	–	40,933	–	93	–	(41,026)	–
Transfer to investment properties (Note iii)	–	(27,939)	–	–	–	–	(27,939)
Disposals	–	(8,387)	(761)	(1,456)	(882)	–	(11,486)
Disposal of a subsidiary (note 41)	–	–	(5,115)	(3,480)	(802)	–	(9,397)
At 31 December 2011	99,395	48,694	20,343	56,773	21,943	338,301	585,449
Additions	–	1,438	6,940	25,499	2,878	105,899	142,654
Acquisition of subsidiaries	–	–	–	1,444	–	–	1,444
Transfer	316,620	43,080	–	–	–	(359,700)	–
Transfer to investment properties (Note iii)	–	(44,008)	–	–	–	–	(44,008)
Disposals	–	(4,300)	–	(2,335)	(217)	–	(6,852)



## 15. Property, Plant And Equipment (continued)

	Hotel buildings RMB'000	Buildings RMB'000	Renovations and leasehold improvements RMB'000	Furniture, fixtures and equipment RMB'000	Motor vehicles RMB'000	Construction in progress RMB'000	Total RMB'000
At 31 December 2012	416,015	44,904	27,283	81,381	24,604	84,500	678,687
DEPRECIATION							
At 1 January 2011	895	6,169	14,048	16,123	8,599	–	45,834
Provided for the year	4,779	1,879	2,219	9,708	2,889	–	21,474
Eliminated on disposals	–	(859)	(760)	(911)	(847)	–	(3,377)
Eliminated on disposal of a subsidiary (note 41)	–	–	(4,907)	(2,472)	(318)	–	(7,697)
At 31 December 2011	5,674	7,189	10,600	22,448	10,323	–	56,234
Provided for the year	14,501	2,206	6,736	10,857	3,178	–	37,478
Eliminated on disposals	–	(425)	–	(248)	(39)	–	(712)
At 31 December 2012	20,175	8,970	17,336	33,057	13,462	–	93,000
CARRYING AMOUNTS							
At 31 December 2012	395,840	35,934	9,947	48,324	11,142	84,500	585,687
At 31 December 2011	93,721	41,505	9,743	34,325	11,620	338,301	529,215

### Notes:

- (i) During the year ended 31 December 2011, buildings of RMB44,906,000 were transferred from completed properties for sale as a result of the change in use of property as approved by the management of the Group.
- (ii) During the year ended 31 December 2011, RMB11,270,000 was transferred from properties under development for sale as a result of change in intended use to self-use properties as approved by the management of the Group.
- (iii) During the year ended 31 December 2012, RMB44,008,000 (2011: RMB27,939,000) was transferred from buildings to investment properties upon change in use as evidenced by signing of relevant tenancy agreements. The excess of the fair value of these properties at the date of change in use over the carrying amounts, amounting to approximately RMB45,708,000 (2011: RMB11,795,000) were recognised in other comprehensive income and accumulated in the property revaluation reserve in equity and non-controlling interests.

The following useful lives are used in the calculation of depreciation:

Hotel buildings	Over the shorter of the term of lease range from 37 years to 47 years or 20 years
Buildings	Over the shorter of the term of lease range from 11 years to 37 years or 50 years
Renovations and leasehold improvements	5–10 years
Furniture, fixtures and equipment	5 years
Motor vehicles	5 to 10 years

At 31 December 2012, certain of the Group's buildings and hotel buildings with carrying amounts of RMB60,561,000 (2011: RMB1,121,000) were pledged to banks to secure certain banking facilities granted to the Group.

The hotel buildings amounting to approximately RMB351,302,000 (2011: RMB47,830,000) and RMB44,538,000 (2011: RMB45,891,000) are held under medium-term and long-term leases in the PRC, respectively. All the buildings are held under medium-term lease in the PRC at the end of both reporting periods.

## NOTES TO THE CONSOLIDATED FINANCIAL STATEMENTS

For the year ended 31 December 2012

### 16. Investment Properties

	Completed Investment properties (at fair value) RMB'000	Investment properties under construction (at fair value) RMB'000	investment properties under construction (at cost) RMB'000	Total RMB'000
<b>FAIR VALUE OR COST</b>				
At 1 January 2011	844,530	–	853,147	1,697,677
Transfer from property, plant and equipment (note 15)	39,734	–	–	39,734
Additions	–	–	278,636	278,636
Transfer from completed properties for sale (note 29)	246,117	–	–	246,117
Transfers upon completion of construction work	993,338	(993,338)	–	–
Transfers to fair value model	–	881,960	(881,960)	–
Disposal	(1,450)	–	–	(1,450)
Net change in fair value recognised in profit or loss	71,602	111,378	–	182,980
At 31 December 2011	2,193,871	–	249,823	2,443,694
Transfer from property, plant and equipment (note 15)	89,716	–	–	89,716
Additions	–	–	154,531	154,531
Transfer from completed properties for sale (note 29)	588,272	–	–	588,272
Transfers upon completion of construction work	269,042	(269,042)	–	–
Transfers to fair value model	–	404,354	(404,354)	–
Disposal	(21,856)	–	–	(21,856)
Net change in fair value recognised in profit or loss	51,188	116,688	–	167,876
At 31 December 2012	3,170,233	252,000	–	3,422,233

At 31 December 2012, the fair values of the Group's completed investment properties of approximately RMB3,170,233,000 (2011: RMB2,193,871,000) and investment properties under development of approximately RMB252,000,000 (2011: nil) at the end of the reporting period were arrived at on the basis of a valuation carried out by Jones Lang LaSalle Sallmanns Limited. Jones Lang LaSalle Sallmanns Limited is a firm of independent qualified professional valuers not connected with the Group, and has appropriate qualifications and recent experiences in the valuation of similar properties in the relevant locations. The valuations of completed investment properties were arrived at by reference to net rental income allowing for reversionary income potential and market evidence of transaction prices for similar properties in the same locations and conditions, where appropriate.

At 31 December 2011, the fair value of investment properties under construction with carrying amounts of approximately RMB249,823,000 were not reliably determinable, therefore, these investment properties under development were measured at cost until either its fair value becomes reliably determinable or construction is completed. During the year ended 31 December 2012, the investment properties under development were substantially completed and therefore fair value can be reliably determined, which has been arrived at using the capitalisation of net income derived from the properties located nearby, taking into account the construction costs that would be expended to complete the development, the developer's profit and percentage of completion of the properties.

At 31 December 2012, investment properties with fair value of RMB633,145,000 (2011: RMB484,365,000) represents completed car parks which can be legally transferred, leased and mortgaged but the title certificates cannot be currently applied as there was no special provisions to obtain any title certificates, according to the relevant laws and regulations in Shenzhen, Suzhou and Tianjin areas.

At 31 December 2012, certain of the Group's investment properties with an aggregate fair value of approximately RMB1,636,564,000 (2011: RMB1,015,147,000) were pledged to banks to secure the banking facilities granted to the Group.

The investment properties amounting to approximately RMB1,185,782,000 (2011: RMB920,737,000) and RMB2,236,451,000 (2011: RMB1,522,957,000) are held under medium-term and long-term leases in the PRC, respectively.

All of the Group's property interests held under operating leases to earn rentals are measured using the fair value model and are classified and accounted for as investment properties.

## 17. Interests in Associates

	31 December 2012 RMB'000	31 December 2011 RMB'000
Cost of investment, unlisted	500	500
Share of post-acquisition results and other comprehensive income, net of dividends received	671	577
	1,171	1,077

As at 31 December 2012 and 2011, the Group had interests in the following associates:

Name of associate	Registered capital	Equity interest attributable to the Group as at 31 December		Principal activities
		2012	2011	
Yuezhong Property Management Company Limited 越眾物業管理有限公司	RMB1,000,000	50%	50%	Property management
Fantasia Investment (Singapore) PTE. LTD 新加坡置富投資有限公司	SGD100	29%	–	Inactive

The summarised financial information in respect of the Group's associates is set out below:

	31 December 2012 RMB'000	31 December 2011 RMB'000
Total assets	6,359	5,796
Total liabilities	(4,017)	(3,641)
Net assets	2,342	2,155
Group's share of net assets of associates	1,171	1,077
	2012 RMB'000	2011 RMB'000
Revenue	9,304	9,622
Total comprehensive income for the year	835	347
Group's share of results of associates	417	171

## NOTES TO THE CONSOLIDATED FINANCIAL STATEMENTS

For the year ended 31 December 2012

### 18. Interest in a Jointly Controlled Entity

	31 December 2012 RMB'000	31 December 2011 RMB'000
Cost of investment, unlisted	19,720	–

As at 31 December 2012, the Group had interest in the following jointly controlled entity:

Name of investee	Total capital amount injected by investors	Group's capital contribution over total capital injected by investors as at 31 December 2012	Principal activity
新疆同之年股權投資合夥企業 (有限合夥) Xinjiang Tongzhinian Equity Investment Partnership (Limited Liability Partnership) ("Xinjiang Tongzhinian")	RMB210,000,000	9.4%	Inactive

Xinjiang Tongzhinian was formed during the year ended 31 December 2012 whereby its principal activity is to carry out investment in property projects. Xinjiang Tongzhinian has not yet commenced its operation up to 31 December 2012. Pursuant to the terms of the joint venture agreement signed on 3 August 2012 between an indirect wholly owned subsidiary of the Company and the other joint venture partner of Xinjiang Tongzhinian, an investment committee was set up by Xinjiang Tongzhinian which has the power to govern the significant investment, operating and financial policies and decisions of Xinjiang Tongzhinian. The Group has the right to appoint three members out of five to the investment committee. Nevertheless, pursuant to the joint venture agreement, all resolutions by the investment committee require two-third of the committee members' approval. As such, the significant investment, financial and operating policies and decision of Xinjiang Tongzhinian require unanimous consent from both the Group and the other joint venture partner. Xinjiang Tongzhinian is regarded as a jointly controlled entity of the Company.

The summarised financial information in respect of the Group's interest in this jointly controlled entity which is accounted for using equity method is set out below:

	31 December 2012 RMB'000
Current assets	19,720

### 19. Advance to an Associate

At 1 January 2011, the amount represented the advance to an associate, Dongguan Zuoting Youyuan, which was non-trade nature and would not be recoverable within one year from the end of the reporting period and therefore considered as a non-current asset. The amount was unsecured, interest-free and measured at amortised cost using the effective interest method at the borrowing rate of 5.48% per annum.

The balance was disposed together with the equity interests held by Group at a cash consideration of RMB96,000,000 during the year ended 31 December 2011.

## 20. Prepaid Lease Payments

The Group's prepaid lease payments comprise:

	31 December 2012 RMB'000	31 December 2011 RMB'000
Leasehold land in the PRC		
Medium-term lease	267,687	68,312
Long-term lease	582,686	101,408
	850,373	169,720

Analysed for reporting purposes as:

	31 December 2012 RMB'000	31 December 2011 RMB'000
Current asset	28,121	6,413
Non-current asset	822,252	163,307
	850,373	169,720

During the year ended 31 December 2012, the Group acquired prepaid lease payments of approximately RMB635,608,000 (2011: RMB19,547,000) through the acquisition of subsidiaries as disclosed in note 40(a).

During the year ended 31 December 2012, the Group acquired prepaid lease payments of approximately RMB461,070,000 (2011: RMB911,507,000) through public auction.

During the year ended 31 December 2012, prepaid lease payments of approximately RMB11,299,000 (2011: RMB7,110,000) were transferred from properties under development for sale as a result of change in intended use of the land to self-use properties.

During the year ended 31 December 2012, prepaid lease payments of RMB461,070,000 (2011: RMB1,114,926,000) was transferred to properties under development for sale upon commencement of the related construction work in certain property development projects.

At 31 December 2012, certain of the Group's prepaid lease payments with a carrying amount of approximately RMB235,757,000 (2011: RMB62,310,000) were pledged to banks to secure the banking facilities granted to the Group.

## NOTES TO THE CONSOLIDATED FINANCIAL STATEMENTS

For the year ended 31 December 2012

### 21. Premium on Prepaid Lease Payments

Premium on prepaid lease payments of the Group represent the excess of the fair value over the carrying amount of the prepaid lease payments and amounting to approximately RMB349,388,000 (2011: RMB185,792,000) and RMB260,975,000 (2011: RMB265,640,000) in respect of leasehold lands in the PRC under medium-term and long-term lease acquired through purchase of subsidiaries during the years and are amortised over the period of the remaining lease term on a straight-line basis.

	RMB'000	
<b>COST</b>		
At 1 January 2011		367,518
Acquisition of assets and liabilities through acquisition of subsidiaries (note 40(a))		187,956
Transfer to properties under development for sale (Note)		(95,000)
At 31 December 2011		460,474
Acquisition of assets and liabilities through acquisition of subsidiaries (note 40(a))		170,064
At 31 December 2012		630,538
<b>AMORTISATION</b>		
At 1 January 2011		2,214
Amortised for the year		6,864
Eliminated on transfer to properties under development for sale (Note)		(36)
At 31 December 2011		9,042
Amortised for the year		11,133
At 31 December 2012		20,175
<b>CARRYING AMOUNTS</b>		
At 31 December 2012		610,363
At 31 December 2011		451,432
	31 December 2012	31 December 2011
	RMB'000	RMB'000
<b>Analysed for reporting purposes as:</b>		
Current asset	19,219	11,157
Non-current asset	591,144	440,275
	610,363	451,432

Note: During the year ended 31 December 2011, premium on prepaid lease payments with carrying amount of approximately RMB94,964,000 was transferred to properties under development for sales upon commencement of the related construction work in certain property development projects.

### 22. Land Development Expenditure

	31 December 2012	31 December 2011
	RMB'000	RMB'000
Cost incurred	1,217,463	1,335,848

## 22. Land Development Expenditure (continued)

- (i) In September 2009, the Group entered into an agreement (“Agreement 1”) with the People’s Government of Pixian County (“Pixian Government”) relating to the joint development of the Wangcong Ancient Sichuan Culture Park located in Pixian County, Chengdu, Sichuan Province (“Land Development Project 1”). Under the Agreement 1, the Group is responsible for preparing overall plans and detailed designs of the culture park including the improvement for parcels of land and its ancillary facilities pursuant to the guidelines set by the Pixian Government as well as the construction of road nearby while the Pixian Government is required to complete the demolition and resettlement work on these parcels of land. The land development expenditure represents the cost incurred in respect of the road construction, demolition and resettlement work. During the year ended 31 December 2012, the addition costs incurred by the Group amounted to approximately RMB202,468,000 (2011: RMB411,999,000), a refund by the Pixian Government based on the cost incurred for certain parcels of the Land Development Project 1 which have been auctioned amounted to approximately RMB345,398,000 (2011: nil), and the balance at 31 December 2012 is RMB662,918,000 (2011: RMB805,848,000).

Pixian Government is required to arrange public auction for these parcels of land after 30 days that the Group completed the related road construction, demolition and resettlement work and the Pixian Government is required to pay certain percentage of sale proceeds received in public auction to the Group by reference to the formula set out in the Agreement 1.

During the year ended 31 December 2012, Pixian Government sold certain parcels of land upon completion of the road construction, demolition and resettlement work, and paid to the Group amounting to approximately RMB345,398,000 upon completion of public auction. These parcels of land were successfully acquired by the Group through public auction. The difference between the refund by the Pixian Government and the cost previously incurred by the Group on developing these parcels of land has been deducted from properties under development for sale as adjustment of land cost upon the purchase of these parcels of land.

The Land Development Project 1 is not expected to be completed within the normal operating cycle of the Group and accordingly is classified as non-current assets.

- (ii) In March 2011, the Group entered into agreement (“Agreement 2”) with the People’s Government of Chengdu (“Chengdu Government”) relating to the development of the Wu Gui Qiao Town located in Jinjiang area, Chengdu, Sichuan Province (“Land Development Project 2”). Under the Agreement 2, the Group is required to jointly construct the ancillary facilities on these parcels of land pursuant to the guidelines set by the Chengdu Government while the Chengdu Government is required to complete the demolition and resettlement work on these parcels of land. The land development expenditure represents the cost incurred for constructing the ancillary facilities. The additions during the year ended 31 December 2012 amounted to approximately RMB24,545,000 (2011: RMB530,000,000) and balance at 31 December 2012 amounted to approximately RMB554,545,000 (2011: RMB530,000,000).

Chengdu Government is required to arrange public auction for these parcels of land on or before 30 June 2013 after the Group has completed the construction of ancillary facilities and the Chengdu Government is required to pay certain percentage of sale proceeds received in public auction to the Group by reference to the formula set out in the Agreement 2.

The Land Development Project 2 is not expected to be completed within the normal operating cycle of the Group and accordingly is classified as non-current assets.

## 23. Deposits Paid for Acquisition of Subsidiaries

As at 31 December 2012, the Group has made deposits of approximately RMB6,890,000 in relation to the acquisition of Nanjing Mingcheng Property Management Company Limited (南京名城物業管理有限公司) (“Nanjing Mingcheng”), Shanghai Tongyi Property Management Company Limited (上海通翼物業有限公司) (“Shanghai Tongyi”) and Liaoning Jixiang Baite Company Limited (遼寧吉祥百特有限公司) (“Liaoning Jixiang”) from third parties. The aforesaid companies are principally engaged in the property management in the PRC. At the date these consolidated financial statements were authorised for issue, the acquisition of Nanjing Mingcheng has been completed, and the acquisition of Shanghai Tongyi and Liaoning Jixiang have not been completed.

As at 31 December 2011, the Group had made deposits of approximately RMB8,084,000 in relation to the acquisition of Nanjing Fantasia Property Management Company Limited (南京花樣年物業管理有限公司) (“Nanjing Fantasia”), Tieling Zhengnan Property Management Company Limited (鐵嶺正南物業管理有限公司) (“Tieling Zhengnan”), Qinhuangdao Hongtianyuan Property Company Limited (秦皇島市宏添源物業公司) (“Qinhuangdao Hongtianyuan”), Shanghai Tongyi and Liaoning Jixiang from third parties. During the year ended 31 December 2012, the acquisition of Nanjing Fantasia, Tieling Zhengnan and Qinhuangdao Hongtianyuan have been completed. Details of the acquisition are set out in note 40(b).

## NOTES TO THE CONSOLIDATED FINANCIAL STATEMENTS

For the year ended 31 December 2012

### 24. Deposit Paid for Acquisition of a Property Project

During the year ended 31 December 2011, the Group had made deposit of approximately RMB104,900,000 in relation to the acquisition of a property project from an independent property developer. During the year ended 31 December 2012, the Group has made additional deposit of approximately RMB21,104,000 for acquiring the aforesaid property project.

The aforesaid deposit relates to acquisition of a building for hotel operations and is therefore classified as non-current assets.

At the date these consolidated financial statements were authorised for issue, the acquisition of the property project has not been completed.

### 25. Deposit Paid for Acquisition of Land Use Rights

As at 31 December 2012, the Group had made deposit of approximately RMB158,123,000 in relation to acquisition of land use rights from the third parties (2011: nil). In the opinion of the directors, the aforesaid transaction is expected to be completed within twelve months from the end of the reporting period.

### 26. Goodwill

	RMB'000
<b>COST</b>	
At 1 January 2011	30,195
Arising on acquisition of business (note 40(b))	1,321
At 31 December 2011	31,516
Arising on acquisition of business (note 40(b))	16,488
At 31 December 2012	48,004
<b>IMPAIRMENT</b>	
At 1 January 2011	30,195
Impairment loss recognised for the year	1,321
At 31 December 2011 and 31 December 2012	31,516
<b>CARRYING AMOUNTS</b>	
At 31 December 2012	16,488
At 31 December 2011	–

During the year ended 31 December 2012, the Group acquired 51% equity interests in Tieling Zhengnan, entire equity interests in Nanjing Fantasia, entire equity interests in Shaanxi Zhongqiang Property Management Company Limited (陝西中強物業管理有限公司) ("Shaanxi Zhongqiang"), entire equity interests in Heyuan Huada Property Management Company Limited (河源華達物業管理有限公司) ("Heyuan Huada") and 51% equity interests in Qinhuangdao Hongtianyuan from independent third parties at total consideration of approximately RMB15,440,000 (note 40(b)). The principal activities of the acquirees are mainly provision of property operation services.

During the year ended 31 December 2011, the Group acquired entire equity interests in Tianjin Xintang Property Management Company Limited (天津新塘物業管理有限公司) ("Tianjin Xintang"), 51% equity interests in Shenzhen Robert Housekeeper Property Management Company Limited (深圳市羅伯特管家物業管理有限公司) and entire equity interests in Huizhou Youling Property Management Company Limited (惠州友鄰物業管理有限公司) from independent third parties at total cash consideration of approximately RMB1,178,000 (note 40(b)). The principal activities of the acquirees are mainly provision of property operation services.

Goodwill acquired in business combination is allocated, at acquisition, to the cash generating units ("CGUs") that are expected to benefit from those business combinations.



## 27. Impairment Testing on Goodwill

During the year ended 31 December 2012, management of the Group determined that there is no impairment of its CGU containing goodwill for the acquisition of businesses.

During the year ended 31 December 2011, in the opinion of the directors, the performance of the businesses during the year was not as good as expected at the time of the acquisition due to the vigorous competition among other competitors and therefore impairment loss of RMB1,321,000 is recognised during the year.

## 28. Deferred Taxation

The following are the major deferred tax liabilities (assets) recognised and movements during the current and prior years are as follow:

	Fair value adjustment of investment properties RMB'000	Revaluation of properties of properties RMB'000	Temporary difference on accruals RMB'000	Tax losses RMB'000	Others (note) RMB'000	Total RMB'000
At 1 January 2011 (restated)	293,834	–	(2,251)	(26,503)	(175,485)	89,595
Charge (credit) to profit or loss (restated)	189,370	–	(8,519)	(40,191)	(25,747)	114,913
Charge to other comprehensive income (restated)	–	4,851	–	–	–	4,851
Underprovision of deferred tax tax assets	–	–	–	–	(813)	(813)
At 31 December 2011 and 1 January 2012 (restated)	483,204	4,851	(10,770)	(66,694)	(202,045)	208,546
Charge to other comprehensive income	–	14,633	–	–	–	14,633
Charge (credit) to profit or loss	264,430	–	844	(43,309)	(81,958)	140,007
At 31 December 2012	747,634	19,484	(9,926)	(110,003)	(284,003)	363,186

Note: Others mainly represents the deductible temporary difference arising from LAT provision.

For the purpose of presentation in the consolidated statement of financial position, certain deferred tax assets and liabilities have been offset. The following is the analysis of the deferred tax balances for financial reporting purposes:

	31 December 2012 RMB'000	31 December 2011 RMB'000 (restated)
Deferred tax assets	(329,372)	(220,826)
Deferred tax liabilities	692,558	429,372
	363,186	208,546

## NOTES TO THE CONSOLIDATED FINANCIAL STATEMENTS

For the year ended 31 December 2012

### 28. Deferred Taxation (continued)

At 31 December 2012, the Group had unutilised tax losses of approximately RMB1,108,746,000 (2011: RMB729,686,000). A deferred tax asset has been recognised in respect of approximately RMB440,012,000 (2011: RMB266,776,000) of such tax losses. No deferred tax asset has been recognised in respect of the remaining tax losses of RMB668,734,000 (2011: RMB462,910,000) due to the unpredictability of future profits streams. Pursuant to the relevant laws and regulations in the PRC, the unrecognised tax losses at the end of the reporting period will expire in the following years:

	2012 RMB'000	2011 RMB'000
2012	–	31,839
2013	17,314	18,102
2014	14,061	15,384
2015	116,575	116,575
2016	237,025	237,025
2017	183,087	–
No expiry	100,672	43,985
	668,734	462,910

At 31 December 2012, the aggregate amount of temporary differences associated with undistributed earnings of subsidiaries, for which deferred tax liabilities have not been recognised, was approximately RMB4,622,423,000 (2011: RMB3,266,386,000). No liability has been recognised in respect of these temporary differences because the Group is in a position to control the timing of the reversal of the temporary difference and it is probable that such differences will not reverse in the foreseeable future.

### 29. Properties for Sale

	31 December 2012 RMB'000	31 December 2011 RMB'000
Completed properties for sale	2,345,047	1,732,813
Properties under development for sale	9,027,581	8,489,507
	11,372,628	10,222,320

At 31 December 2012, certain of the Group's properties for sale with a carrying amount of RMB3,060,355,000 (2011: RMB1,434,836,000) were pledged to secure certain banking facilities granted to the Group.

During the year ended 31 December 2011, RMB44,906,000 and RMB11,270,000 were transferred to property, plant and equipment and construction in progress under property, plant and equipment respectively, as a result of change in intended use to operate hotel business and for self used buildings as approved by the management of the Group.

During the year ended 31 December 2012, RMB11,299,000 (2011: RMB7,110,000) was transferred to prepaid lease payments, as a result of change in intended use to operate hotel business and for self used buildings as approved by the management of the Group.

During the year ended 31 December 2012, completed properties for sale with an aggregate amount of approximately RMB258,015,000 (2011: RMB54,975,000) were transferred to investment properties upon change in use as evidenced by signing of relevant tenancy agreements. The excess of the fair value of these properties at the date of transfer over their carrying amounts, amounting to approximately RMB330,257,000 (2011: RMB191,142,000) were recognised in the consolidated statement of comprehensive income.

Included in the amount are properties under development for sale of approximately RMB4,239,726,000 (2011: RMB2,451,117,000) in relation to property development projects that are expected to complete after one year from the end of the reporting periods.

### 30. Trade and Other Receivables

Trade receivables are mainly arisen from sales of properties, rental income derived from investment properties, agency fee income in respect of property rentals, service and management income in respect of property management.

Considerations in respect of properties sold are received in accordance with the terms of the related sales and purchase agreements, certain portion are received on or before the date of delivery of the properties to customers which is recorded as deposits received for sale of properties. The remaining balances (net of deposit received in advance) are settled upon the release of funds from banks under mortgage facilities.

Rental income from investment properties is received in accordance with the terms of the relevant lease agreements, normally within 30 days from the issuance of invoices.

Management and service fee income is received in accordance with the terms of the relevant property service agreements, normally within 30–90 days from the issuance of invoices.

Hotel operation income is in the form of cash sales.

	2012 RMB'000	2011 RMB'000
Trade receivables	964,674	410,171
Other receivables	109,523	93,568
Prepayments and other deposits	62,424	57,032
Prepayments for suppliers	217,188	280,925
Prepayments for construction work	643,326	293,111
Other tax prepayment (Note)	145,366	81,570
	2,142,501	1,216,377

Note: During the year ended 31 December 2012, the Group is required to prepay business tax amounting to approximately RMB187,493,000 (2011: RMB142,902,000) in accordance with the relevant PRC tax rules in respect of its pre-sale of property development projects. As at 31 December 2012, amount of approximately RMB132,308,000 (2011: RMB81,029,000) has been prepaid and included in other tax prepayment.

The following is an aged analysis of trade receivables of the Group net of allowance for doubtful debts presented based on the invoice date at the end of the reporting period:

	31 December 2012 RMB'000	31 December 2011 RMB'000
0 to 30 days	487,829	214,728
31 to 90 days	256,995	150,069
91 to 180 days	30,727	25,401
181 to 365 days	113,747	16,072
Over 1 year	75,376	3,901
	964,674	410,171

The trade receivables as at 31 December 2012 included the receivables from the property sales of approximately RMB870,465,000 whereby the banks have agreed to provide mortgage facilities to the properties purchasers and the banks are in process of releasing the funds to the Group.

For property investment and property operating services, before accepting any new customer, the Group would assess the potential customer's credit quality and defined credit rating limits of each customers. Limits attributed to customers are reviewed once a year.

In determining the recoverability of a trade receivable, the Group considers any change in the credit quality of the trade receivable from the date credit was initially granted up to the reporting date and no impairment is necessary for those balances which are not past due.

## NOTES TO THE CONSOLIDATED FINANCIAL STATEMENTS

For the year ended 31 December 2012

### 30. Trade and Other Receivables (continued)

At 31 December 2012, included in the Group's trade receivable balance (excluding debtors which pending from banks to release fund) with aggregate carrying amount of approximately RMB26,709,000 (2011: RMB17,593,000) and are past due for which the Group has not provided for impairment loss as there has not been a significant change in credit quality and amounts are still considered recoverable based on historical experience. The Group does not hold any collateral over these balances.

#### Ageing of trade receivables which are past due but not impaired

	31 December 2012 RMB'000	31 December 2011 RMB'000
91 to 180 days	3,620	8,782
181 to 365 days	15,427	4,910
Over 1 year	7,662	3,901
	26,709	17,593

#### Movement in the allowance for doubtful debts in respect of trade and other receivables

	2012 RMB'000	2011 RMB'000
Balance at the beginning of the year	2,672	2,937
Impairment losses reversed	(1,558)	(2,812)
Impairment losses recognised	12,105	2,547
Balance at the end of the year	13,219	2,672

As at 31 December 2012, included in the allowance for doubtful debts are individually impaired trade and other receivables with an aggregate balance of RMB13,219,000 (2011: RMB2,672,000) of which the debtors have been in dispute with the Group.

### 31. Amounts Due from Related Parties

	31 December 2012 RMB'000	31 December 2011 RMB'000
深圳市天闊投資發展有限公司 Shenzhen Tiankuo Investment Development Company Limited ("Shenzhen Tiankuo") (note)	–	3,262

Note: The balance represents the advance to Shenzhen Tiankuo, a related company controlled by Ms. Zeng Jie, Baby, the controlling shareholder and director of the Company. The amount was unsecured, non-interest bearing and was non-trade nature. The amount was settled during the year ended 31 December 2012.

## 32. Amounts Due from Customers for Contract Works

	31 December 2012 RMB'000	31 December 2011 RMB'000
Contract costs incurred plus recognised profits less recognised losses	403,327	112,415
Less: Progress billings	(353,136)	(96,056)
	50,191	16,359
Analysed for reporting purposes as:		
Amounts due from customers for contract works	52,482	16,359
Amounts due to customers for contract works	(2,291)	–
	50,191	16,359

## 33. Financial Assets at Fair Value Through Profit or Loss

During the year ended 31 December 2012, the Group entered into several contracts of structured deposits with banks. The return and principal were not guaranteed by the relevant banks and the return was determined by reference to the performance of certain PRC government debt instruments and treasury notes. The entire combined contracts have been designated as at financial assets at FVTPL on initial recognition. The expected return rate stated in the contracts ranges from 2.3% to 4.4% per annum.

In the opinion of the directors, the fair value of the structured deposits at 31 December 2012 approximated their principal amounts. At the date the consolidated financial statements are authorised for issue, structured deposits amounting to approximately RMB31,200,000 have been settled after 31 December 2012 at their principal amounts together with returns which approximated the expected return. The remaining principal amounts together with the expected returns will be received by the Group when the structured deposits mature during the year ending 31 December 2013.

## 34. Restricted Bank Deposits/Bank Balances and Cash

### Restricted bank deposits

The deposits carry interest rates ranging from 0.4% to 0.5% (2011: 0.4% to 0.5%) per annum. The restricted bank deposits amounting to approximately RMB61,343,000 (2011: RMB62,198,000) will be released upon the buyers obtaining the individual property ownership certificate, while a total amount RMB466,133,000 (2011: RMB252,936,000) are proceeds from presale of properties with the restriction of use for settlement of construction costs for relevant property projects, and term deposits amounting to approximately RMB180,138,000 (2011: nil) were pledged to banks to secure the short term banking facilities granted to the Group.

### Bank balances and cash

The bank balances carry variable interest rates ranging from 0.4% to 2.9% (2011: 0.4% to 3.1%) per annum.

At 31 December 2012, bank balances of the Group denominated in USD, HKD, TWD and JPY foreign currencies of the relevant group entities, are approximately RMB1,030,061,000 (2011: RMB5,195,000), RMB60,681,000 (2011: RMB288,798,000) and RMB1,693,000 (2011: RMB3,496,000), RMB8,000 (2011:nil), respectively.

## NOTES TO THE CONSOLIDATED FINANCIAL STATEMENTS

For the year ended 31 December 2012

### 35. Trade and Other Payables

	31 December 2012 RMB'000	31 December 2011 RMB'000
Trade payables	1,730,059	1,696,289
Other payables*	332,415	254,332
Other tax payables	161,339	104,674
Payroll payable	48,181	50,403
Welfare payable	3,315	695
Retention payable	54,796	29,330
Consideration payable (note 40)	257,630	128,267
Accruals	15,722	4,839
	2,603,457	2,268,829

\* Included in other payables is an amount of approximately RMB57,023,000 (2011: RMB45,644,000) which relates to the earnest money received from potential property buyers.

Trade payables principally comprise amounts outstanding for purchase of materials for the construction of properties for sale and ongoing expenditures. The average credit period for purchase of construction materials ranged from six months to one year.

The following is an aged analysis of the Group's trade payables and retention payable presented based on the invoice date at the end of the reporting period:

	31 December 2012 RMB'000	31 December 2011 RMB'000
0 to 60 days	1,269,307	1,325,615
61 to 180 days	296,571	261,680
181 to 365 days	103,925	23,344
1-2 years	77,074	94,931
2-3 years	21,054	16,238
Over 3 years	16,924	3,811
	1,784,855	1,725,619

At 31 December 2012, the balances of approximately RMB54,796,000 (2011: RMB29,330,000) with age over one year represent the retention money of approximately 5% to 10% of the construction contract price.

## 36. Amounts Due to Related Parties

	31 December 2012 RMB'000	31 December 2011 RMB'000
深圳立方建築設計顧問有限公司 Shenzhen Cube Architecture Designing Consultants Company Limited ("Cube Architecture") (Note i)	1,150	2,547
深圳市安美華照明有限公司 Shenzhen City Anmeihua Lighting Company Limited ("Anmeihua Lighting ") (Note ii)	423	–
	1,573	2,547

### Notes:

- (i) Cube Architecture is an associate of Shenzhen Tiankuo (defined in note 31), a related company controlled by Ms. Zeng Jie, Baby, the controlling shareholder and director of the Company. The amount is unsecured, non-interest bearing and represents the payables to Cube Architecture for the design fee of several property projects of the Group, and accordingly classified as trade nature. The aging of the balance is within 90 days.
- (ii) Anmeihua Lighting is a non-controlling shareholder which held 49% equity interests in a subsidiary of the Company. The amount is unsecured, non-interest bearing and is non-trade nature.

## 37. Borrowings

	31 December 2012 RMB'000	31 December 2011 RMB'000
Bank loans	5,002,407	4,273,002
Other loans (Note i)	550,000	468,000
	5,552,407	4,741,002
Secured	3,951,677	4,711,002
Unsecured	1,600,730	30,000
	5,552,407	4,741,002
<i>Carrying amount repayable (Note ii):</i>		
Within one year	1,860,653	1,896,308
More than one year, but not exceeding two years	1,910,568	1,216,000
More than two years, but not exceeding five years	1,427,002	936,824
More than five years	354,184	691,870
	5,552,407	4,741,002
Less: Carrying amount of bank loans that are not repayable within one year from the end of the reporting period but contain a repayment on demand clause (shown under current liabilities)	(591,641)	(203,761)
Less: Amounts due within one year shown under current liabilities	(1,860,653)	(1,896,308)
	3,100,113	2,640,933

### Notes:

- (i) Other loans amounting to RMB550,000,000 (2011: RMB468,000,000) represent loans provided by certain trust companies, which are secured, carry interest of 13.5% to 17.0% (2011: 15.39%) per annum and repayable on 20 June 2013 to 5 January 2014 (2011: 30 April 2012). Included in these other loans are loans amounting to RMB420,000,000 (2011: nil) which are secured by certain directors (note 47).
- (ii) The amounts due are based on scheduled repayment dates set out in the loan agreements.

## NOTES TO THE CONSOLIDATED FINANCIAL STATEMENTS

For the year ended 31 December 2012

### 37. Borrowings (continued)

At 31 December 2012, all borrowings are denominated in RMB except that secured borrowings amounting to approximately RMB916,586,000 (2011: RMB844,321,000) and RMB137,841,000 (2011: RMB163,762,000) are denominated in USD and HKD respectively, foreign currency of relevant group entities.

The analysis of the Group's fixed-rate borrowings based on their contractual maturity dates (or reset dates) are as follows:

	31 December 2012 RMB'000	31 December 2011 RMB'000
Fixed-rate borrowings:		
Within one year	392,000	–
More than one year, but not exceeding two years	200,000	–
	592,000	–

In addition, the Group has variable-rate borrowings which carry interest linked to LIBOR, HIBOR and Benchmark Rate. Interest is reset every six months. The analysis of the Group's variable-rate borrowings based on their contractual maturity dates are as follows:

	31 December 2012 RMB'000	31 December 2011 RMB'000
Variable-rate borrowings:		
Within one year	1,468,653	1,896,308
More than one year, but not exceeding two years	1,710,568	1,216,000
More than two years, but not exceeding five years	1,427,002	936,824
More than five years	354,184	691,870
	4,960,407	4,741,002

The ranges of effective interest rates (which are the contracted interest rates) on the Group's borrowings are as follows:

	2012	2011
Effective interest rate:		
Fixed-rate borrowings	12.6% to 18.0% per annum	N/A
Variable-rate borrowings		
LIBOR	+2.0% per annum	+2.0% per annum
HIBOR	+2.0% per annum	+2.0% per annum
Benchmark Rate	-0.4% to +2.6% per annum	-1.5% to +5.9% per annum



## 38. Senior Notes

### (a) Senior note due 2015

On 12 May 2010, the Company issued senior notes in an aggregate principal amount of US\$120,000,000 (the "Notes 1"). The issue price is 98.3% of the principal amount of the Notes 1. The Notes 1 are listed on the Singapore Exchange Securities Trading Limited. The Notes 1 carry interest of 14.0% per annum and interest is payable semi-annually on 12 May and 12 November in arrears. The Notes 1 will mature on 12 May 2015, unless redeemed earlier.

At any time, the Company may at its option redeem the Notes 1, in whole but not in part, at a redemption price equal to 100% of the principal amount of the Notes 1 plus applicable premium as defined in the offering memorandum of the Company dated 5 May 2010 ("Applicable Premium 1") as of, and accrued and unpaid interest, if any to (but not including) the redemption date.

Applicable Premium 1 is the greater of (1) 1% of the principal amount of such Notes 1 and (2) the excess of the amount equivalent to the principal amount and related interest up to 12 May 2015 discounted at a rate equal to comparable treasury price in United States plus 100 basis points over the principal amount.

At any time and from time to time prior to 12 May 2013, the Company may redeem up to 35% of the aggregate principal amount of the Notes 1 with the net cash proceeds of one or more sales of ordinary shares of the Company in an equity offering at a redemption price of 114% of the principal amount of the Notes 1, plus accrued and unpaid interest, if any, to (but not including) the redemption date.

The Notes 1 contain a liability component and the above early redemption options:

- (i) Liability component represents the present value of the contractually determined stream of future cash flows discounted at the prevailing market interest rate at that time applicable to instruments of comparable credit status and providing substantially the same cash flows, on the same terms, but without the embedded derivatives.

The interest charged for the year is calculated by applying an effective interest rate of approximately 14.9% per annum to the liability component since the Notes 1 were issued.

- (ii) Early redemption options are regarded as embedded derivatives not closely related to the host contract. The directors consider that the fair value of the above early redemption options is insignificant on initial recognition, at 31 December 2011 and at 31 December 2012.

### (b) Senior note due 2017

On 27 September 2012, the Company issued senior notes in an aggregate principal amount of US\$250,000,000 (the "Notes 2"). The issue price is 99.5% of the principal amount of the Notes 2. The Notes 2 are listed on the Singapore Exchange Securities Trading Limited. The Notes 2 carry interest of 13.8% per annum and interest is payable semi-annually on 27 March and 27 September in arrears. The Notes will mature on 27 September 2017, unless redeemed earlier.

The Notes 2 may be redeemed in the following circumstances:

At any time, the Company may at its option redeem the Notes 2, in whole but not in part, at a redemption price equal to 100% of the principal amount of the Notes plus applicable premium as defined in the offering memorandum of the Company dated 20 September 2012 ("Applicable Premium 2") as of, and accrued and unpaid interest, if any to (but not including) the redemption date.

Applicable Premium 2 is the greater of (1) 1% of the principal amount of such Notes 2 and (2) the excess of the amount equivalent to the principal amount and related interest up to 27 September 2017 discounted at a rate equal to comparable treasury price in United States plus 100 basis points over the principal amount.

At any time and from time to time prior to 27 September 2015, the Company may redeem up to 35% of the aggregate principal amount of the Notes 2 with the net cash proceeds of one or more sales of ordinary shares of the Company in an equity offering at a redemption price of 113.8% of the principal amount of the Notes 2, plus accrued and unpaid interest, if any, to (but not including) the redemption date.

## NOTES TO THE CONSOLIDATED FINANCIAL STATEMENTS

For the year ended 31 December 2012

### 38. Senior Notes (continued)

#### (b) Senior note due 2017 (continued)

The Notes 2 contain a liability component and the above early redemption options:

- (i) Liability component represents the present value of the contractually determined stream of future cash flows discounted at the prevailing market interest rate at that time applicable to instruments of comparable credit status and providing substantially the same cash flows, on the same terms, but without the embedded derivatives.

The interest charged for the year is calculated by applying an effective interest rate of approximately 14.8% per annum to the liability component since the Notes 2 were issued.

- (ii) Early redemption options are regarded as embedded derivatives not closely related to the host contract. The directors consider that the fair value of the above early redemption options is insignificant on initial recognition and at 31 December 2012.

	2012 RMB'000	2011 RMB'000
Carrying amount as at 1 January	752,367	787,330
Net proceeds on the date of issuance	1,530,324	–
Exchange gain	(16,408)	(38,384)
Interest expenses	169,161	113,413
Less: interest paid to note holders	(106,441)	(109,992)
Carrying amount as at 31 December	2,329,003	752,367

The fair value of the senior notes at 31 December 2012 amounted to approximately RMB2,662,171,000 (2011: RMB593,482,000). The fair value is calculated using the market price of the senior notes at the end of reporting period (or the nearest day of trading).

### 39. Share Capital

	Number of shares	Amount HK\$	Equivalent to RMB'000
Ordinary shares of HK\$0.1 each			
Authorised:			
At 1 January 2011, 31 December 2011, and 31 December 2012	8,000,000,000	800,000,000	704,008
Issued and fully paid:			
At 1 January 2011	4,873,888,750	487,388,875	429,389
Subscription of new shares (Note)	333,333,000	33,333,300	27,704
At 31 December 2011 and 31 December 2012	5,207,221,750	520,722,175	457,093

Note: On 24 June 2011, the Company and the former non-controlling shareholder of a subsidiary ("Subscriber") entered into a subscription agreement, which the Subscriber has agreed to subscribe for the subscription shares ("Subscription Shares") at a total subscription amount of RMB332,440,000. The issue price of the Subscription Shares is HK\$1.2 per share which is determined with reference to the share price quoted on The Stock Exchange of Hong Kong Limited on 24 June 2011.

The Subscription Shares represent approximately 6.8% of the then existing issued share capital of the Company as at 24 June 2011 and approximately 6.4% of the enlarged issued share capital of the Company immediately after issue of the Subscription Shares. The Company intends to use the proceeds to finance continuing capital expenditure requirements and as general working capital for the Group's operating activities.

On 30 June 2011, total 333,333,000 Subscription Shares have been allotted and issued by the Company. These new issued shares rank pari passu with existing shares.

## 40. Acquisitions of Subsidiaries

### (a) Acquisitions of assets and liabilities through acquisitions of subsidiaries

#### *For the year ended 31 December 2012*

On 31 December 2012, the Group acquired a parcel of land through the acquisition of 61% equity interests in Topsearch Printed Circuits (Shenzhen) Ltd. (至卓飛高線路板(深圳)有限公司) from an independent third party at a cash consideration of approximately RMB213,421,000.

On 20 November 2012, the Group acquired another parcel of land through the acquisition of 100% equity interests in Huawanli Investment (Beijing) Company Limited (花萬里投資(北京)有限公司) from another independent third party at a cash consideration of approximately RMB458,850,000, after deducting an amount of RMB320,300,000 relating to the amount owed by the purchaser to Huawanli Investment (Beijing) Company Limited (花萬里投資(北京)有限公司) at the date of acquisition.

The above transactions were accounted for as purchase of assets and liabilities. Details of the net assets acquired in respect of the above transactions is summarised below:

	RMB'000
Net assets acquired	
Prepaid lease payments	635,608
Premium on prepaid lease payments	170,064
Property, plant and equipment	1,154
Other receivables	1,246
Bank balances and cash	776
Other payables	(127)
	808,721
Identifiable net assets shared by non-controlling interests	(136,450)
	672,271
Total consideration satisfied by:	
Cash	458,850
Consideration payable (note)	213,421
	672,271
Net cash (outflow) inflow arising on acquisitions	
Cash consideration paid during the year	(458,850)
Bank balances and cash acquired	776
	(458,074)

Note: In 2013, the consideration payable has been settled.

## NOTES TO THE CONSOLIDATED FINANCIAL STATEMENTS

For the year ended 31 December 2012

### 40. Acquisitions of Subsidiaries (continued)

#### (a) Acquisitions of assets and liabilities through acquisitions of subsidiaries (continued)

##### *For the year ended 31 December 2011*

On 19 August 2011, the Group acquired a parcel of land through the acquisition of 100% equity interests in TCL King Electronics (Shenzhen) Company Limited (TCL王牌電子(深圳)有限公司) from third parties at a cash consideration of approximately RMB309,345,000.

The above transaction was accounted for as purchase of assets and liabilities. Details of the net assets acquired in respect of the above transactions is summarised below:

	RMB'000
Net assets acquired	
Prepaid lease payments	19,547
Premium on prepaid lease payments	187,956
Amount due from the Group	70,000
Other receivables	30,231
Bank balances and cash	1,777
Other payables	(166)
	309,345
Total consideration satisfied by:	
Cash	182,000
Consideration payables (note)	127,345
	309,345
Net cash (outflow) inflow arising on acquisition	
Cash consideration paid during the year	(182,000)
Bank balances and cash acquired	1,777
	(180,223)

Note: During the year ended 31 December 2012, the Group had settled RMB87,114,000 for the consideration payable due as at 31 December 2011.

#### (b) Acquisition of business

##### *For the year ended 31 December 2012*

During the year ended 31 December 2012, the Group acquired five subsidiaries from various independent third parties which the acquirees are principally engaged in provision of property operation services and were acquired with the objective of expansion of property operation services.

On 3 January 2012, the Group acquired 51% equity interests in Tieling Zhengnan at a consideration of approximately RMB1,980,000.

On 1 March 2012, the Group acquired entire equity interests in Nanjing Fantasia at a consideration of approximately RMB4,000,000.

On 1 July 2012, the Group acquired entire equity interests in Shaanxi Zhongqiang at a consideration of approximately RMB800,000.

On 8 August 2012, the Group acquired entire equity interests in Heyuan Huada at a consideration of approximately RMB5,680,000.

On 20 September 2012, the Group acquired 51% equity interests in Qinhuangdao Hongtianyuan at a consideration of approximately RMB2,980,000.

#### 40. Acquisitions of Subsidiaries (continued)

##### (b) Acquisition of business (continued)

*For the year ended 31 December 2012 (continued)*

*Consideration transferred*

	RMB'000
Cash	12,384
Consideration payables	3,056
<b>Total</b>	<b>15,440</b>

Acquisition-related costs were insignificant and have been excluded from the cost of acquisition and have been recognised as an expense in the period within the "administrative expenses" line item in the consolidated statement of comprehensive income.

Assets acquired and liabilities recognised at the date of acquisition are as follows:

	RMB'000
Property, plant and equipment	290
Trade and other receivables	13,675
Bank balances and cash	5,457
Trade and other payables	(15,695)
Tax payable	(10)
	<b>3,717</b>

The trade and other receivables acquired with a fair value of approximately RMB13,675,000 had gross contractual amounts of approximately RMB13,675,000.

*Goodwill arising on acquisition*

	RMB'000
Consideration transferred	15,440
Non-controlling interests	4,765
Less: fair value of net assets acquired	(3,717)
<b>Goodwill arising on acquisition</b>	<b>16,488</b>

The non-controlling interests amounting to approximately RMB4,765,000, was measured by reference to the proportionate share of the 49% of Tieling Zhengnan and 49% of Qinhuangdao Hongtianyuan's net identifiable assets at the acquisition date.

Goodwill arose on the acquisitions of Tieling Zhengnan, Nanjing Fantasia, Shaanxi Zhongqiang, Heyuan Huada and Qinhuangdao Hongtianyuan is because the acquisitions included the benefit of expected synergies and the future profitability as at acquisition date. These benefits could not be separately recognised from goodwill because they do not meet the recognition criteria for identifiable intangible assets.

None of the goodwill arising on this acquisition is expected to be deductible for tax purposes.

## NOTES TO THE CONSOLIDATED FINANCIAL STATEMENTS

For the year ended 31 December 2012

### 40. Acquisition of Subsidiaries (continued)

#### (b) Acquisition of business (continued)

**For the year ended 31 December 2012** (continued)

*Net cash outflow arising on acquisition*

	RMB'000
Cash consideration paid	12,384
Less: deposits paid in 2011	(6,874)
Less: bank balances and cash acquired	(5,457)
	53

Included in the profit for the year ended 31 December 2012 is approximately RMB1,887,000 attributable to the additional businesses generated by Tieling Zhengnan, Nanjing Fantasia, Shaanxi Zhongqiang, Heyuan Huada and Qinhuangdao Hongtianyuan in total. Revenue for the year includes approximately RMB23,855,000 generated from Tieling Zhengnan, Nanjing Fantasia, Shaanxi Zhongqiang, Heyuan Huada and Qinhuangdao Hongtianyuan in total.

Had the above acquisitions been completed on 1 January 2012, the revenue of the Group for the year ended 31 December 2012 would have been approximately RMB6,283,792,000, and the profit for the year would have been approximately RMB1,127,267,000.

The proforma information is for illustrative purposes only and is not necessarily an indication of revenue and results of operations of the Group that actually would have been achieved had the acquisition been completed at 1 January 2012, nor is intended to be a projection of future results.

#### **For the year ended 31 December 2011**

On 19 April 2011, the Group acquired 100% equity interests in Tianjin Xintang from an independent third party at a consideration of approximately RMB78,000.

On 1 July 2011, the Group acquired 100% equity interests in Huizhou Youling from an independent third party at a consideration of approximately RMB500,000.

On 12 July 2011, the Group acquired 51% equity interests in Shenzhen Robert from an independent third party at a consideration of approximately RMB600,000.

The acquirees are principally engaged in provision of property operation services and were acquired with the objective of expansion of property operation services.

#### *Consideration transferred*

	RMB'000
Cash	256
Consideration payables (note)	922
Total	1,178

Note: During the year ended 31 December 2012, the Group has not yet settled for the consideration payable due as at 31 December 2011.

Acquisition-related costs were insignificant and have been excluded from the cost of acquisition and have been recognised as an expense in the period within the "administrative expenses" line item in the consolidated statement of comprehensive income.

#### 40. Acquisition of Subsidiaries (continued)

##### (b) Acquisition of business (continued)

**For the year ended 31 December 2011** (continued)

*Consideration transferred* (continued)

Assets acquired and liabilities recognised at the date of acquisition are as follows:

	RMB'000
Property, plant and equipment	18
Other receivables	1,157
Bank balances and cash	1,078
Trade and other payables	(2,629)
Tax payable	(27)
	(403)

The other receivables acquired with a fair value of approximately RMB1,157,000 had gross contractual amounts of approximately RMB1,157,000.

*Goodwill arising on acquisition*

	RMB'000
Consideration transferred	1,178
Non-controlling interests	(260)
Plus: fair value of net liabilities acquired	403
Goodwill arising on acquisition	1,321

The non-controlling interests amounting to approximately RMB260,000, was measured by reference to the proportionate share of the 49% of Shenzhen Robert's net identifiable liabilities at the acquisition date.

Goodwill arose on the acquisition of Tianjin Xintang, Huizhou Youling and Shenzhen Robert because the acquisition included the control premium and the future profitability as at acquisition date. These benefits could not be separately recognised from goodwill because they do not meet the recognition criteria for identifiable intangible assets.

None of the goodwill arising on this acquisition is expected to be deductible for tax purposes.

*Net cash inflow arising on acquisition*

	RMB'000
Cash consideration paid	(256)
Bank balances and cash acquired	1,078
	822

## NOTES TO THE CONSOLIDATED FINANCIAL STATEMENTS

For the year ended 31 December 2012

### 40. Acquisition of Subsidiaries (continued)

#### (b) Acquisition of business (continued)

**For the year ended 31 December 2011** (continued)

*Impact of acquisition on the results of the Group*

Included in the profit for the year ended 31 December 2011 is approximately RMB117,000 attributable to the additional businesses generated by Tianjin Xintang, Huizhou Youling and Shenzhen Robert in total. Revenue for the year includes approximately RMB4,396,000 generated from Tianjin Xintang, Huizhou Youling and Shenzhen Robert in total.

Had the above acquisition been completed on 1 January 2011, the revenue of the Group for the year ended 31 December 2011 would have been approximately RMB5,594,993,000, and the profit for the year would have been approximately RMB1,209,661,000.

The proforma information is for illustrative purposes only and is not necessarily an indication of revenue and results of operations of the Group that actually would have been achieved had the acquisition been completed at 1 January 2011, nor is intended to be a projection of future results.

### 41. Disposal of a Subsidiary

For the year ended 31 December 2011

On 14 February 2011, the Group disposed of its entire 85% equity interests in Shenzhen Xingyan Property Consultancy Company Limited (深圳市星彥地產顧問有限公司) ("Shenzhen Xingyan") to an independent third party for a consideration of approximately RMB21,250,000. Shenzhen Xingyan was engaged in provision of property agency services.

	RMB'000
<b>Consideration satisfied by:</b>	
Cash	14,875
Consideration receivable	6,375
	21,250
<b>Analysis of assets and liabilities over which control was lost:</b>	
Property, plant and equipment	1,700
Trade and other receivables	2,415
Amounts due from Fantasia group companies	5,531
Bank balances and cash	3,184
Trade and other payables	(7,256)
Tax payable	(1,267)
	4,307
<b>Gain on disposal of a subsidiary:</b>	
Cash consideration	14,875
Consideration receivable	6,375
Non-controlling interests	646
Net assets disposed of	(4,307)
	17,589
<b>Net cash inflow arising on disposal:</b>	
Cash consideration	14,875
Bank balances and cash disposed of	(3,184)
	11,691

Note: The consideration receivable amounting to RMB6,375,000 has been settled during the year ended 31 December 2012.



## 42. Operating Lease Commitments

### The Group as lessee

At the end of the reporting period, the Group had commitments for future minimum lease payments under non-cancellable operating leases which fall due as follows:

	2012 RMB'000	2011 RMB'000
Within one year	11,709	7,022
In the second to the fifth year inclusive	34,703	18,428
After the fifth year	3,310	5,638
	49,722	31,088

Operating lease payments represent rentals payable by the Group for certain offices premises. Leases are negotiated for an average term of 1 to 10 years with fixed rentals.

### The Group as lessor

At the end of the reporting period, the Group has contracted with tenants for the following future minimum lease payments:

	2012 RMB'000	2011 RMB'000
Within one year	89,603	50,426
In the second to the fifth year inclusive	249,858	174,104
After the fifth year	132,139	106,234
	471,600	330,764

Property rental income represents rentals receivable by the Group. Leases are negotiated for an average term of 1 to 18 years with fixed rentals.

## 43. Other Commitments

	2012 RMB'000	2011 RMB'000
Construction commitments in respect of properties for sale contracted for but not provided in the consolidated financial statements	4,615,929	2,525,242
Land development expenditure commitments in respect of development cost contracted for but not provided in the consolidated financial statements	91,130	98,202
Construction commitments in respect of investment properties contracted for but not provided in the consolidated financial statements	47,192	206,353
Construction commitments in respect of hotels contracted for but not provided in the consolidated financial statements	54,482	41,646

## NOTES TO THE CONSOLIDATED FINANCIAL STATEMENTS

For the year ended 31 December 2012

### 44. Share Option Scheme

The Company's share option scheme (the "Scheme") was adopted pursuant to a resolution passed on 27 October 2009 for the primary purposes of providing incentives to certain directors and employees of the Company and its subsidiaries ("Eligible Employees"), and will expire on 28 August 2021 and 15 October 2022. Under the Scheme, the Board of Directors of the Company is authorised to grant options at a consideration of HK\$1 per option to the Eligible Employees to subscribe for shares in the Company ("Shares").

The maximum number of Shares which may be issued upon exercise of all options to be granted under the Scheme ("Options") and any other share option schemes of the Company shall not, in the absence of shareholders' approval, in aggregate exceed 10% of the shares of the Company in issue at any point in time. Options granted to a substantial shareholder or an independent non-executive director in excess of 0.1% of the Company's share capital or with a value in excess of HK\$5 million must be approved in advance by the Company's shareholders.

The exercisable period of an option is determined by the directors at their discretion. The expiry date of the option may be determined by the Board of Directors of the Company which shall not be later than the expiry day of the Scheme.

The exercise price is determined by the directors of the Company, and will not be less than the greater of: (i) the closing price of the Company on the offer date; (ii) the average of the closing price of the Company's shares for the five trading days immediately preceding the offer of the options and (iii) the nominal value per share of the Company.

As at 31 December 2012, the total number of shares to be issued upon the exercise of all options granted under the Scheme is 119,400,000 (2011: 74,230,000) of HK\$0.1 each, representing approximately 2.3% (2011: 1.4%) of the issued share capital of the Company.

Details of the share options granted under the Scheme during the years ended 31 December 2011 and 2012 is as follows:

Category of Grantee	Date of grant	Exercise price per share	Exercisable period	Vesting period
Directors	29 August 2011	HK\$0.836	29/08/2012–28/08/2021	29/08/2011–28/08/2012
			29/08/2013–28/08/2021	29/08/2011–28/08/2013
			29/08/2014–28/08/2021	29/08/2011–28/08/2014
	16 October 2012	HK\$0.8	16/10/2013–15/10/2022	16/10/2012–15/10/2013
			16/10/2014–15/10/2022	16/10/2012–15/10/2014
			16/10/2015–15/10/2022	16/10/2012–15/10/2015
Employees	29 August 2011	HK\$0.836	29/08/2012–28/08/2021	29/08/2011–28/08/2012
			29/08/2013–28/08/2021	29/08/2011–28/08/2013
			29/08/2014–28/08/2021	29/08/2011–28/08/2014
	16 October 2012	HK\$0.8	16/10/2013–15/10/2022	16/10/2012–15/10/2013
			16/10/2014–15/10/2022	16/10/2012–15/10/2014
			16/10/2015–15/10/2022	16/10/2012–15/10/2015

#### 44. Share Option Scheme (continued)

The following table discloses movements of the Company's share options held by employees and directors during the years ended 31 December 2012 and 2011:

Category of Grantees	Date of grant	Exercisable period	Vesting period	Outstanding at 1 January 2011	Granted and outstanding at 31 December 2011	Granted during the year	Cancelled/lapsed during the year	Exercised during the year	Outstanding at 31 December 2012
Directors	29 August 2011	29/08/2012 – 28/08/2021	29/08/2011 – 28/08/2012	–	2,201,000	–	(883,000)	–	1,318,000
		29/08/2013 – 28/08/2021	29/08/2011 – 28/08/2013	–	4,402,000	–	(1,766,000)	–	2,636,000
		29/08/2014 – 28/08/2021	29/08/2011 – 28/08/2014	–	15,407,000	–	(6,181,000)	–	9,226,000
	16 October 2012	16/10/2013 – 15/10/2022	16/10/2012 – 15/10/2013	–	–	1,872,000	(277,000)	–	1,595,000
		16/10/2014 – 15/10/2022	16/10/2012 – 15/10/2014	–	–	3,744,000	(554,000)	–	3,190,000
		16/10/2015 – 15/10/2022	16/10/2012 – 15/10/2015	–	–	13,104,000	(1,939,000)	–	11,165,000
				–	22,010,000	18,720,000	(11,600,000)	–	29,130,000
Employees	29 August 2011	29/08/2012 – 28/08/2021	29/08/2011 – 28/08/2012	–	5,222,000	–	(1,041,000)	–	4,181,000
		29/08/2013 – 28/08/2021	29/08/2011 – 28/08/2013	–	10,444,000	–	(2,082,000)	–	8,362,000
		29/08/2014 – 28/08/2021	29/08/2011 – 28/08/2014	–	36,554,000	–	(7,287,000)	–	29,267,000
	16 October 2012	16/10/2013 – 15/10/2022	16/10/2012 – 15/10/2013	–	–	4,971,000	(125,000)	–	4,846,000
		16/10/2014 – 15/10/2022	16/10/2012 – 15/10/2014	–	–	9,942,000	(250,000)	–	9,692,000
		16/10/2015 – 15/10/2022	16/10/2012 – 15/10/2015	–	–	34,797,000	(875,000)	–	33,922,000
				–	52,220,000	49,710,000	(11,660,000)	–	90,270,000
<b>Total</b>			–	74,230,000	68,430,000	(23,260,000)	–	119,400,000	
Exercisable at the end of the year					–			5,499,000	

The closing price of the shares on the date of grant was HK\$0.82 at 29 August 2011 and HK\$0.77 at 16 October 2012. Binomial Option Pricing Model has been used to estimate the fair value of the options. The variables and assumptions used in computing the fair value of the share options are based on the Company's best estimate. The value of an option varies with different variables of certain subjective assumptions. The inputs into the model are as follows:

	16 October 2012	29 August 2011
Market price	HK\$0.770	HK\$0.820
Exercise price	HK\$0.800	HK\$0.836
Expected volatility	44.87%	40.43%
Risk-free rate	0.66%	1.74%
Expected dividend yield	5.195%	4.878%

During the year ended 31 December 2012, the estimated fair value of the options at the date of grant is approximately RMB13,680,000. During the year ended 31 December 2011, the estimated fair values of the options at the date of grant is approximately RMB15,225,000. The Group recognised the total expense of approximately RMB5,180,000 for the year ended 31 December 2012 (2011: RMB2,240,000) in relation to share options granted by the Company.

## NOTES TO THE CONSOLIDATED FINANCIAL STATEMENTS

For the year ended 31 December 2012

### 45. Retirement Benefits Plans

The Group operates a Mandatory Provident Fund Scheme for all qualifying employees in Hong Kong. The assets of the scheme are held separately from those of the Group, in funds under control of a trustee. The Group contributes lower of 5% of relevant payroll costs or HK\$1,250 per person per month to the Scheme, which is matched by employees.

The employees of the Group in the PRC are members of state-managed retirement benefit scheme operated by the PRC Government. The Company's subsidiary is required to contribute a certain percentage of payroll to the retirement benefit schemes to fund the benefits. The only obligation of the Group with respect to the scheme is to make the required contributions under the scheme.

### 46. Contingent Liabilities

	2012 RMB'000	2011 RMB'000
Guarantees given to banks for mortgage facilities granted to purchasers of the Group's properties	2,750,751	2,478,814

The Group had provided guarantees in respect of mortgage facilities granted by certain banks in connection with the mortgage loans entered into by purchasers of the Group's properties. Pursuant to the terms of the guarantees, if there is default of the mortgage payments by these purchasers, the Group is responsible to repay the outstanding mortgage loans together with accrued interests thereon and any penalty owed by the defaulted purchasers to banks. The Group is then entitled to take over the legal title of the related properties. The guarantee period commences from the dates of grant of the relevant mortgage loans and ends after the buyer obtained the individual property ownership certificate.

In the opinion of the directors, the fair value of guarantee contracts is insignificant at initial recognition. Also, no provision for the guarantee contracts at the end of the reporting period is recognised as the default risk is low.

## 47. RELATED PARTY DISCLOSURES

- 1) During the year, in addition to those disclosed in notes 31 and 36, the Group had significant transactions with related parties as follows:

Related parties	Relationship	Transactions	2012 RMB'000	2011 RMB'000
Huidong Dayawan San Jiao Zhou Company Limited 惠東縣大亞灣三角洲俱樂部有限公司	Company controlled by Ms. Zeng Jie, Baby, a controlling shareholder and director of the Company	Management service fee recognised	612	980
Shenzhen Xi Fu Hui Club Management Company Limited 深圳喜福會會所管理有限公司	Company controlled by Ms. Zeng Jie, Baby, a controlling shareholder and director of the Company	Property rental income recognised	301	301
Cube Architecture	An associate of Shenzhen Tiankuo, (defined in note 31), a related company controlled by Ms. Zeng Jie, Baby, the controlling shareholder and director of the Company	Design services fee incurred	1,099	4,154
Yu Shui 于水	Non-controlling shareholder of a subsidiary of the Company	Consideration paid in respect of acquisition of additional interest in a subsidiary of the Group	–	332,440
Zhongxu Investment Limited 中旭投資有限公司	Non-controlling shareholder of a subsidiary of the Company	Consideration paid in respect of acquisition of additional interest in a subsidiary of the Group	–	10,000

- 2) Compensation of key management personnel

The remuneration of directors and other members of key management during the year is as follows:

	2012 RMB'000	2011 RMB'000
Short-term benefit	50,422	61,260
Post-employment benefit	7,501	2,663
Share-based payment	4,803	1,985
	62,726	65,908

- 3) Others

As at 31 December 2012 and 2011, certain directors of the Company provided joint guarantees to the banks and trust company to secure the Group's bank and other borrowings amounting to RMB620,000,000 in aggregate.

During the year ended 31 December 2012, the Group sold certain properties to two directors of the Company, at a cash consideration of approximately RMB8,629,000 (2011: RMB3,391,000), the Group had sold certain properties to its key management personnels (excluding the aforesaid directors) of the Group, at a cash consideration of approximately RMB17,536,000 (2011: RMB3,068,000).

## NOTES TO THE CONSOLIDATED FINANCIAL STATEMENTS

For the year ended 31 December 2012

### 48. Particulars of Principal Subsidiaries of the Company

Particulars of principal subsidiaries indirectly held, unless otherwise stated, by the Company at 31 December 2012 and 2011 are as follows:

Name of subsidiary	Place and date of incorporation/ establishment	Issued and fully paid share/ registered capital	Proportion ownership interest held by the Group		Principal activities	Legal form
			2012	2011		
Winning Sky International Limited	The BVI 8 March 2006	US\$100	100% (directly)	100% (directly)	Investment holding	Private limited liability
Fantastic Victory Limited	The BVI 3 September 2007	US\$100	100% (directly)	100% (directly)	Investment holding	Private limited liability
Wisdom Regal Limited	The BVI 3 September 2007	US\$100	100% (directly)	100% (directly)	Investment holding	Private limited liability
Colour Life Services Group Co., Ltd ("Colour life Services")	The Cayman Islands 16 March 2012	HK\$1,000	70% (directly)	70% (directly)	Investment holding	Private limited liability
Ace Link Pacific Limited <sup>#</sup>	The BVI 3 September 2007	US\$100	70%	70%	Investment holding	Private limited liability
Precise Idea Limited	The BVI 17 June 2009	US\$1	100% (directly)	100% (directly)	Investment holding	Private limited liability
Talent Bright International Limited	The BVI 17 June 2009	US\$1	100% (directly)	100% (directly)	Investment holding	Private limited liability
香港花樣年投資控股集團有限公司 Fantasia Investment Holdings Company Limited ("Fantasia Investment Holdings")	Hong Kong 19 February 2001	HK\$10,000	100%	100%	Investment holding	Private limited liability
悅泰投資有限公司 Joytime Investment Limited	Hong Kong 6 November 2007	HK\$10,000	100%	100%	Investment holding	Private limited liability
金展集團有限公司 Gold Genius Holdings Limited <sup>#</sup>	Hong Kong 8 November 2007	HK\$10,000	100%	100%	Investment holding	Private limited liability
花樣年酒店管理(國際)有限公司 Fantasia Hotel Management (International) Company Limited	Hong Kong 15 July 2009	HK\$1	100%	100%	Investment holding	Private limited liability
花樣年物業管理(國際)有限公司 Fantasia Property Management (International) Company Limited	Hong Kong 15 July 2009	HK\$1	100%	100%	Investment holding	Private limited liability
香港康年貿易有限公司 Hong Kong Kangnian Trading Company Limited	Hong Kong 24 September 2009	US\$500,000	100%	100%	Trading and investment holding	Private limited liability

#### 48. Particulars of Principal Subsidiaries of the Company (continued)

Name of subsidiary	Place and date of incorporation/ establishment	Issued and fully paid share/ registered capital	Proportion ownership interest held by the Group		Principal activities	Legal form
			2012	2011		
花樣年集團(中國)有限公司 Fantasia Group (China) Company Limited*	The PRC 20 January 2006	RMB1,624,843,500	100%	100%	Investment holding and property development	Limited liability company
天津松江花樣年置業有限公司 Tianjin Songjiang Fantasia Real Estate Company Limited*	The PRC 29 May 2006	RMB50,000,000	60%	60%	Property development	Limited liability company
深圳市花樣年地產集團有限公司 Shenzhen Fantasia Real Estate Group Limited* ("Shenzhen Fantasia")	The PRC 28 September 1996	RMB150,000,000	100%	100%	Investment holding, property development and investment	Limited liability company
深圳市彩生活服務集團有限公司 Shenzhen Fantasia Colour Life Service Group Limited*	The PRC 25 August 2006	RMB15,000,000	70%	70%	Investment holding	Limited liability company
惠州大亞灣花萬裏實業有限公司 Huizhou Daya Bay Huawanli Industry Company Limited*	The PRC 8 June 2007	RMB51,000,000	100%	100%	Property development	Limited liability company
天津市花樣年投資有限公司 Tianjin Fantasia Investment Company Limited*	The PRC 12 June 2006	RMB100,000,000	100%	100%	Property development	Limited liability company
成都通和置業有限公司 Chengdu Tonghe Real Estate Company Limited*	The PRC 18 October 2001	RMB75,610,000	100%	100%	Property development and investment	Limited liability company
深圳市花千里房地產開發有限公司 Shenzhen Huaqianli Real Estate Investment Development Company Limited*	The PRC 28 August 2006	RMB660,339,487	100%	100%	Investment holding	Limited liability company
深圳置富房地產開發有限公司 Shenzhen Zhifu Real Estate Investment Development Company Limited*	The PRC 1 July 1994	RMB946,843,500	100%	100%	Property development and investment	Limited liability company
深圳宏威裝飾設計工程有限公司 Shenzhen Hongwei Decoration & Designing Company Limited*	The PRC 25 May 1994	RMB10,000,000	100%	100%	Provision of interior design services	Limited liability company
深圳市花樣年物業管理有限公司 Shenzhen Fantasia Property Management Company Limited**	The PRC 11 December 2000	RMB5,000,000	100%	100%	Provision of property operation services	Limited liability company

## NOTES TO THE CONSOLIDATED FINANCIAL STATEMENTS

For the year ended 31 December 2012

### 48. Particulars of Principal Subsidiaries of the Company (continued)

Name of subsidiary	Place and date of incorporation/ establishment	Issued and fully paid share/ registered capital	Proportion ownership interest held by the Group		Principal activities	Legal form
			2012	2011		
深圳市彩生活網絡服務有限公司 Shenzhen Colour Life Network Services Company Limited**	The PRC 12 June 2007	RMB10,000,000	100%	100%	Provision of property operation services	Limited liability company
深圳市開元同濟樓宇科技有限公司 Shenzhen Kaiyuan Tongji Building Science & Technology Company Limited**	The PRC 15 November 2001	RMB5,000,000	100%	100%	Provision of security system design, installation and maintenance services	Limited liability company
深圳市蓮塘物業管理有限公司 Shenzhen Liantang Property Management Company Limited**	The PRC 16 November 1999	RMB5,500,000	100%	100%	Provision of property operation services	Limited liability company
花樣年實業發展(成都)有限公司 Fantasia (Chengdu) Development Company Limited*	The PRC 4 July 2001	RMB50,000,000	100%	100%	Property development and investment	Limited liability company
花樣年(成都)生態旅遊開發有限公司 Fantasia (Chengdu) Ecological Tourism Development Company Limited*	The PRC 7 September 2006	RMB1,344,970,000	100%	100%	Property development	Limited liability company
成都花萬裏置業有限公司 Chengdu Huawanli Real Estate Company Limited*	The PRC 25 October 2005	RMB100,000,000	100%	100%	Property development and investment	Limited liability company
成都花千里置業有限公司 Chengdu Huaqianli Real Estate Company Limited*	The PRC 6 November 2006	RMB704,680,000	100%	100%	Property development	Limited liability company
成都花百里置業有限公司 Chengdu Huabaili Real Estate Company Limited*	The PRC 22 May 2003	RMB270,000,000	100%	100%	Property development	Limited liability company
東莞市花樣年房地產投資有限公司 Dongguan Fantasia Real Estate Investment Company Limited*	The PRC 4 December 2006	RMB30,000,000	100%	100%	Property development	Limited liability company
雅浩科技發展(深圳)有限公司 Yahao Technology Development (Shenzhen) Company Limited**	The PRC 25 August 2005	HKD1,000,000	100%	100%	Investment holding	Limited liability company
深圳市康年科技有限公司 Shenzhen Kangnian Technology Company Limited*	The PRC 9 February 2007	RMB100,000,000	100%	100%	Property development and investment	Limited liability company
四川西美投資有限公司 Sichuan Ximei Investment Company Limited*	The PRC 7 June 2004	RMB670,000,000	100%	100%	Property development	Limited liability company



#### 48. Particulars of Principal Subsidiaries of the Company (continued)

Name of subsidiary	Place and date of incorporation/ establishment	Issued and fully paid share/ registered capital	Proportion ownership interest held by the Group		Principal activities	Legal form
			2012	2011		
天津福大房地產銷售有限公司 Tianjin Fuda Real Estate Development Company Limited*	The PRC 18 October 2004	RMB45,000,000	100%	100%	Property development	Limited liability company
宜興市江南水鄉度假村有限公司 Yixing Jiangnan Shuixiang Tourism Resort Company Limited*	The PRC 19 April 2005	RMB28,000,000	60%	60%	Property development	Limited liability company
深圳市星彥行置業有限公司 Shenzhen Xingyanhang Property Company Limited**	The PRC 23 April 2007	RMB4,000,000	92.65%	92.65%	Provision of agency services	Limited liability company
成都新津友幫房地產開發有限 責任公司 Chengdu Xinjin Youbang Real Estate Development Company Limited*	The PRC 9 May 2004	RMB85,000,000	100%	100%	Property development	Limited liability company
成都花樣年望叢文化發展有限公司 Chengdu Fantasia Wangcong Culture Development Company Limited*	The PRC 6 August 2008	RMB300,000,000	100%	100%	Property development	Limited liability company
成都九蓉房地產開發有限公司 Chengdu Jiurong Real Estate Development Limited*	The PRC 22 August 2007	RMB320,000,000	100%	100%	Property development	Limited liability company
深圳花樣年商業管理有限公司 Shenzhen Fantasia Business Management Company Limited*	The PRC 3 June 2009	RMB120,000,000	100%	100%	Provision of property operation services	Limited liability company
深圳市花樣年酒店管理有限公司 Shenzhen Fantasia Hotel Management Company Limited*	The PRC 3 June 2009	RMB100,000,000	100%	100%	Hotel services	Limited liability company
深圳市彩悅酒店管理有限公司 Shenzhen Caiyue Hotel Management Company Limited**	The PRC 20 August 2008	RMB100,000	100%	100%	Hotel services	Limited liability company
深圳市彩悅酒店有限公司 Shenzhen Caiyue Hotel Company Limited**	The PRC 15 January 2009	RMB100,000	100%	100%	Hotel services	Limited liability company
寧夏回族自治區新聖基建築工程 有限公司 Ningxia Hui Nationality Autonomous Region Xingshengji Construction Company Limited*	The PRC 22 July 2009	RMB50,000,000	100%	100%	Provision of construction services	Limited liability company

## NOTES TO THE CONSOLIDATED FINANCIAL STATEMENTS

For the year ended 31 December 2012

### 48. Particulars of Principal Subsidiaries of the Company (continued)

Name of subsidiary	Place and date of incorporation/ establishment	Issued and fully paid share/ registered capital	Proportion ownership interest held by the Group		Principal activities	Legal form
			2012	2011		
深圳滙恒置業有限公司 Shenzhen Huiheng Property Company Limited*	The PRC 20 April 2006	RMB150,000,000	100%	100%	Property development	Limited liability company
惠州市惠陽區花千里實業有限公司 Huizhou Huiyang Huaqianli Industry Company Limited.*	The PRC 14 August 2011	RMB100,000,000	100%	100%	Property development	Limited liability company
花千里投資(北京)有限公司 Huaqianli Investment (Beijing) Company Limited.*	The PRC 15 March 2011	RMB10,000,000	100%	100%	Investment Holding	Limited liability company
蘇州花萬里房地產開發有限公司 Suzhou Huawanli Real Estate Company Limited*	The PRC 9 September 2009	RMB180,000,000	100%	100%	Property development	Limited liability company
蘇州林甲岩房產發展有限公司 Suzhou LKN Real Estate Company Limited*	The PRC 5 July 1994	RMB180,599,652	100%	100%	Property development	Limited liability company
深圳市匯港物業管理有限公司 Shenzhen Hui Gang Property Management Company Limited**	The PRC 12 April 2002	RMB3,000,000	75%	75%	Provision of property operation services	Limited liability company
深圳市蓮塘物業管理有限公司 Shenzhen Liangtang Property Management Company Limited*	The PRC 16 November 1999	RMB5,500,000	100%	100%	Provision of property operation services	Limited liability company
成都市花樣年物業服務有限公司 Chengdu Fantasia Property Service Company Limited*	The PRC 23 December 2009	RMB5,000,000	100%	100%	Provision of property operation services	Limited liability company
東莞花千里房地產開發有限公司 Dongguan Huaqianli Property Development Company Limited*	The PRC 30 April 2011	RMB30,000,000	100%	100%	Property development	Limited liability company
深圳高華投資有限公司 Shenzhen Gao Hua Investment Limited*	The PRC 12 March 2011	RMB200,000,000	100%	100%	Investment holding, property development and investment	Limited liability company
成都市諾亞舟實業有限公司 Chengdu Nuoyazhou Development Company Limited*	The PRC 17 June 2008	RMB300,000,000	100%	100%	Property development	Limited liability company
江蘇東發置業有限公司 Jiangsu Dongfa Real Estate Company Limited*	The PRC 2 March 2009	RMB20,000,000	100%	100%	Property development	Limited liability company
桂林萬豪房地產開發有限公司 Guilin Wanhao Property Development Limited*	The PRC 14 November 2007	RMB250,000,000	100%	100%	Property development	Limited liability company

#### 48. Particulars of Principal Subsidiaries of the Company (continued)

Name of subsidiary	Place and date of incorporation/ establishment	Issued and fully paid share/ registered capital	Proportion ownership interest held by the Group		Principal activities	Legal form
			2012	2011		
桂林聚豪房地產開發有限公司 Guilin Juhao Property Development Limited*	The PRC 14 November 2007	RMB250,000,000	100%	100%	Property development	Limited liability company
成都花港置業有限公司 Chendu Huagang Real Estate Company Limited*	The PRC 14 April 2012	RMB200,000,000	100%	100%	Property development	Limited liability company
TCL王牌電子(深圳)有限公司 TCL King Electronics (Shenzhen) Company Limited*	The PRC 9 October 1981	HKD100,000,000	100%	100%	Property development	Limited liability company
惠州市友鄰物業管理有限公司 Huizhou Youling Property Management Company Limited**	The PRC 13 June 2008	RMB500,000	100%	100%	Provision of property operation services	Limited liability company
天津新塘物業管理有限公司 Tianjin Xintang Property Management Company Limited**	The PRC 21 May 2007	RMB500,000	100%	100%	Provision of property operation services	Limited liability company
深圳市羅伯特管家物業管理有限公司 Shenzhen Robert Housekeeper Property Management Company Limited**	The PRC 9 April 2002	RMB1,000,000	51%	51%	Provision of property operation services	Limited liability company
鐵嶺正南物業管理有限公司 Tieling Zhengnan Property Management Company Limited**A	The PRC 18 March 2008	RMB500,000	51%	–	Provision of property operation services	Limited liability company
南京花樣年物業管理有限公司 Nanjing Fantasia Property Management Company Limited**A	The PRC 29 June 2000	RMB5,000,000	100%	–	Provision of property operation services	Limited liability company
陝西中強物業管理有限公司 Shaanxi Zhongqiang Property Management Company Limited**A	The PRC 8 September 2003	RMB3,000,000	100%	–	Provision of property operation services	Limited liability company
河源市華達物業管理有限公司 Heyuan Huada Property Management Company Limited**A	The PRC 12 June 2002	RMB3,000,000	100%	–	Provision of property operation services	Limited liability company
秦皇島市宏添源物業服務有限公司 Qinhuangdao Hongtianyuan Property Service Company Limited**A	The PRC 25 October 2005	RMB5,000,000	51%	–	Provision of property operation services	Limited liability company
至卓飛高線路板(深圳)有限公司 Topsearch Printed Circuits (Shenzhen) Ltd <sup>A</sup>	The PRC 25 September 1987	RMB391,093,510	61%	–	Property Development	Limited liability company

## NOTES TO THE CONSOLIDATED FINANCIAL STATEMENTS

For the year ended 31 December 2012

### 48. Particulars of Principal Subsidiaries of the Company (continued)

Name of subsidiary	Place and date of incorporation/ establishment	Issued and fully paid share/ registered capital	Proportion ownership interest held by the Group		Principal activities	Legal form
			2012	2011		
花萬里投資(北京)有限公司 Huawanli Investment (Beijing) Company Limited* <sup>^</sup>	The PRC 13 September 2011	RMB779,150,000	100%	–	Property Development	Limited liability company
深圳市花萬里酒店管理有限公司 Shenzhen Huawanli Hotel* Management Company Limited	The PRC 23 October 2012	RMB1,000,000	100%	–	Hotel Management	Limited liability company
深圳市花樣年養生養老管理有限公司 Shenzhen Fantasia Senior Housing Management Company Limited*	The PRC 23 October 2012	RMB1,000,000	100%	–	Investment holding	Limited liability company
深圳市花樣年文化旅遊管理有限公司 Shenzhen Fantasia Culture Tourism Management Company Limited*	The PRC 15 October 2012	RMB1,000,000	100%	–	Investment holding	Limited liability company
深圳市花萬里商業管理有限公司 Shenzhen Huawanli Commercial Management Company Limited*	The PRC 15 October 2012	RMB1,000,000	100%	–	Investment holding	Limited liability company
大理市花千里文化旅遊開發有限公司 Dali Huaqianli Culture Tourism Development Company Limited*	The PRC 4 July 2012	RMB100,000,000	100%	–	Investment holding	Limited liability company
成都望叢房地產開發有限公司 Chengdu Wangcong Property Development Company Limited*	The PRC 28 June 2012	RMB20,000,000	100%	–	Property development	Limited liability company
深圳市同之年股權投資 基金管理有限公司 Shenzhen Tongzhinian Equity Investment Fund Management Company Limited*	The PRC 20 August 2012	RMB10,000,000	54%	–	Investment holding	Limited liability company
深圳市花樣年股權投資 基金管理有限公司 Shenzhen Fantasia Equity Investment Fund Management Company Limited*	The PRC 15 May 2012	RMB10,000,000	100%	–	Investment holding	Limited liability company
惠州市花樣年房地產開發有限公司 Huizhou Fantasia Property Development Company Limited*	The PRC 23 March 2012	RMB1,000,000	100%	–	Property development	Limited liability company

\* The English name is for identification purpose only.

# These subsidiaries were held by a non-wholly owned subsidiary of the Company namely Colour Life Services at 31 December 2012.

<sup>^</sup> These subsidiaries were acquired during the year ended 31 December 2012. Details are set out in note 40.

The above table lists the subsidiaries of the Group which, in the opinion of the directors, principally affected the results or assets of the Group. To give details of other subsidiaries would, in the opinion of the directors, result in particulars of excessive length.

## 49. Information About the Statement of Financial Position of the Company

Information about the statement of financial position of the Company at the end of the reporting period includes:

	2012 RMB'000	2011 RMB'000
<b>NON-CURRENT ASSETS</b>		
Investments in unlisted subsidiaries	1,196,233	932,758
Advance to subsidiaries	4,263,648	3,475,509
	5,459,881	4,408,267
<b>CURRENT ASSETS</b>		
Other receivables	1,204	–
Banks balances and cash	248,259	49,229
	249,463	49,229
<b>CURRENT LIABILITIES</b>		
Amounts due to subsidiaries	204,208	417,478
Accruals	5,745	4,364
	209,953	421,842
<b>NET CURRENT ASSETS (LIABILITIES)</b>	39,510	(372,613)
<b>TOTAL ASSETS LESS CURRENT LIABILITIES</b>	5,499,391	4,035,654
<b>NON-CURRENT LIABILITY</b>		
Senior notes	2,329,003	752,367
	3,170,388	3,283,287
<b>CAPITAL AND RESERVES</b>		
Share capital (see note 39)	457,093	457,093
Reserves	2,713,295	2,826,194
	3,170,388	3,283,287

Movement of reserves:

	Share capital RMB'000	Share premium RMB'000	Accumulated profits RMB'000	Share options reserve RMB'000	Total RMB'000
At 1 January 2011	429,389	2,481,236	86,082	–	2,996,707
Subscription of new shares (note 39)	27,704	304,736	–	–	332,440
Profit and total comprehensive income for the year	–	–	117,788	–	117,788
Recognition of equity-settled share-based payments (note 44)	–	–	–	2,240	2,240
Dividend paid to shareholders of the Company (note 13)	–	(165,888)	–	–	(165,888)
At 31 December 2011	457,093	2,620,084	203,870	2,240	3,283,287
Profit and total comprehensive income for the year	–	–	50,780	–	50,780
Recognition of equity-settled share-based payments (note 44)	–	–	–	5,180	5,180
Dividend paid to shareholders of the Company (note 13)	–	(168,859)	–	–	(168,859)
At 31 December 2012	457,093	2,451,225	254,650	7,420	3,170,388

## 50. Events After the Reporting Period

On 22 January 2013, the Company issued additional senior notes with principal amount of US\$250,000,000 at an issue price of 100% of the face value of the notes, which are unsecured and bear coupon interest at 10.75% per annum payable semi-annually in arrears and are due on 22 January 2020 and an announcement on the issue of this additional senior notes had been made by the Company on 16 January 2013.

## INDEPENDENT AUDITOR'S REPORT

# Deloitte.

## 德勤

TO THE MEMBERS OF FANTASIA HOLDINGS GROUP CO., LIMITED

花樣年控股集團有限公司

*(Incorporated in the Cayman Islands with limited liability)*

We have audited the consolidated financial statements of Fantasia Holdings Group Co., Limited (the "Company") and its subsidiaries (collectively referred to as the "Group") set out on pages 59 to 142, which comprise the consolidated statement of financial position as at 31 December 2011, and the consolidated statement of comprehensive income, consolidated statement of changes in equity and consolidated statement of cash flows for the year then ended, and a summary of significant accounting policies and other explanatory information.

### **Directors' Responsibility for the Consolidated Financial Statements**

The directors of the Company are responsible for the preparation of the consolidated financial statements that give a true and fair view in accordance with Hong Kong Financial Reporting Standards issued by the Hong Kong Institute of Certified Public Accountants and the disclosure requirements of the Hong Kong Companies Ordinance, and for such internal control as the directors determine is necessary to enable the preparation of the consolidated financial statements that are free from material misstatement, whether due to fraud or error.

### **Auditor's Responsibility**

Our responsibility is to express an opinion on these consolidated financial statements based on our audit and to report our opinion solely to you, as a body, in accordance with our agreed terms of engagement, and for no other purpose. We do not assume responsibility towards or accept liability to any other person for the contents of this report. We conducted our audit in accordance with Hong Kong Standards on Auditing issued by the Hong Kong Institute of Certified Public Accountants. Those standards require that we comply with ethical requirements and plan and perform the audit to obtain reasonable assurance about whether the consolidated financial statements are free from material misstatement.

An audit involves performing procedures to obtain audit evidence about the amounts and disclosures in the consolidated financial statements. The procedures selected depend on the auditor's judgment, including the assessment of the risks of material misstatement of the consolidated financial statements, whether due to fraud or error. In making those risk assessments, the auditor considers internal control relevant to the entity's preparation of the consolidated financial statements that give a true and fair view in order to design audit procedures that are appropriate in the circumstances, but not for the purpose of expressing an opinion on the effectiveness of the entity's internal control. An audit also includes evaluating the appropriateness of accounting policies used and the reasonableness of accounting estimates made by the directors, as well as evaluating the overall presentation of the consolidated financial statements.

We believe that the audit evidence we have obtained is sufficient and appropriate to provide a basis for our audit opinion.

### **Opinion**

In our opinion, the consolidated financial statements give a true and fair view of the state of affairs of the Group as at 31 December 2011, and of the Group's profit and cash flows for the year then ended in accordance with Hong Kong Financial Reporting Standards and have been properly prepared in accordance with the disclosure requirements of the Hong Kong Companies Ordinance.

Deloitte Touche Tohmatsu

*Certified Public Accountants*

Hong Kong

12 March 2012

## CONSOLIDATED STATEMENT OF COMPREHENSIVE INCOME

For the year ended 31 December 2011

	Notes	2011 RMB'000	2010 RMB'000
Revenue	7	5,592,350	4,471,234
Cost of sales and services		(3,200,650)	(2,546,440)
Gross profit		2,391,700	1,924,794
Other income, gains and losses	8	46,922	32,199
Change in fair value of investment properties	16	182,980	320,461
Recognition of change in fair value of completed properties for sale upon transfer to investment properties	28	191,142	67,326
Selling and distribution expenses		(262,433)	(131,278)
Administrative expenses		(309,972)	(238,724)
Finance costs	9	(108,471)	(180,131)
Impairment loss recognised in respect of goodwill	26	(1,321)	(5,375)
Share of results of associates		171	406
Gain on disposal of an associate		3,533	–
Gain on disposal of a subsidiary	39	17,589	–
Profit before taxation	10	2,151,840	1,789,678
Income tax expense	11	(942,199)	(828,708)
Profit for the year		1,209,641	960,970
<b>Other comprehensive income (expense)</b>			
Surplus on revaluation of properties		11,795	–
Deferred taxation liability arising from revaluation of properties		(2,949)	–
Other comprehensive income for the year (net of income tax)		8,846	–
Total comprehensive income for the year		1,218,487	960,970
Profit for the year attributable to:			
Owners of the Company		1,153,624	807,281
Non-controlling interests		56,017	153,689
		1,209,641	960,970
Total comprehensive income attributable to:			
Owners of the Company		1,162,470	807,281
Non-controlling interests		56,017	153,689
		1,218,487	960,970
Earnings per share – Basic (RMB)	14	0.23	0.17

## CONSOLIDATED STATEMENT OF FINANCIAL POSITION

At 31 December 2011

	Notes	2011 RMB'000	2010 RMB'000
<b>NON-CURRENT ASSETS</b>			
Property, plant and equipment	15	529,215	374,434
Investment properties	16	2,443,694	1,697,677
Interests in associates	17	1,077	17,795
Advance to an associate	18	–	72,041
Prepaid lease payments	19	163,307	346,045
Premium on prepaid lease payments	20	440,275	359,203
Prepayment		11,890	43,370
Land development expenditure	21	1,335,848	393,849
Deposits paid for acquisition of subsidiaries	23	8,084	–
Deposits paid for acquisition of a property project	24	104,900	37,000
Deferred tax assets	27	220,826	157,504
		5,259,116	3,498,918
<b>CURRENT ASSETS</b>			
Properties for sale	28	10,222,320	7,644,582
Prepaid lease payments	19	6,413	6,881
Premium on prepaid lease payments	20	11,157	6,101
Deposits paid for acquisition of land use rights	22	–	763,095
Trade and other receivables	29	1,216,377	977,179
Amounts due from related parties	30	3,262	7,500
Amounts due from customers for contract works	31	16,359	15,939
Tax recoverable		51,143	5,580
Restricted bank deposits	32	315,134	85,161
Bank balances and cash	32	1,021,355	2,371,452
		12,863,520	11,883,470
<b>CURRENT LIABILITIES</b>			
Trade and other payables	33	2,268,829	1,686,718
Deposits received for sale of properties		2,619,004	1,834,067
Amounts due to related parties	34	2,547	100,549
Tax payable		1,527,259	1,104,147
Borrowings – due within one year	35	2,100,069	2,132,381
		8,517,708	6,857,862
<b>NET CURRENT ASSETS</b>		4,345,812	5,025,608
<b>TOTAL ASSETS LESS CURRENT LIABILITIES</b>		9,604,928	8,524,526



	Notes	2011 RMB'000	2010 RMB'000
<b>NON-CURRENT LIABILITIES</b>			
Deferred tax liabilities	27	212,347	128,121
Borrowings – due after one year	35	2,640,933	2,642,605
Senior notes	36	752,367	787,330
		3,605,647	3,558,056
		5,999,281	4,966,470
<b>CAPITAL AND RESERVES</b>			
Share capital	37	457,093	429,389
Reserves		5,361,531	4,072,745
Equity attributable to owners of the Company		5,818,624	4,502,134
Non-controlling interests		180,657	464,336
		5,999,281	4,966,470

The consolidated financial statements on pages 59 to 142 were approved and authorised for issue by the Board of Directors on 12 March 2012 and are signed on its behalf by:

**Pan Jun**  
*DIRECTOR*

**Chan Sze Hon**  
*DIRECTOR*

## CONSOLIDATED STATEMENT OF CHANGES IN EQUITY

For the year ended 31 December 2011

	Attributable to owners of the Company											
	Share capital	Share premium	Special reserve	Share option reserve	Contribution reserve	Statutory reserves	Discretionary reserves	Property revaluation reserve	Accumulated profits	Total	Non-controlling interests	Total
	RMB'000	RMB'000	RMB'000	RMB'000	RMB'000	RMB'000	RMB'000	RMB'000	RMB'000	RMB'000	RMB'000	RMB'000
		(Note i)	(Note ii)	(Note iii)		(Note iv)	(Note iv)	(Note v)				
At 1 January 2010	429,389	2,556,336	(595)	-	40,600	31,120	1,477	-	711,932	3,770,259	311,102	4,081,361
Profit and total comprehensive income for the year	-	-	-	-	-	-	-	-	807,281	807,281	153,689	960,970
Acquisition of additional interest in a subsidiary	-	-	(306)	-	-	-	-	-	-	(306)	-	(306)
Acquisition of subsidiaries (note 38(b))	-	-	-	-	-	-	-	-	-	-	42	42
Contribution from non-controlling shareholders	-	-	-	-	-	-	-	-	-	-	2,800	2,800
Transfer	-	-	-	-	-	2,985	-	-	(2,985)	-	-	-
Dividend paid to non-controlling shareholders	-	-	-	-	-	-	-	-	-	-	(3,297)	(3,297)
Dividend paid to shareholders of the Company	-	(75,100)	-	-	-	-	-	-	-	(75,100)	-	(75,100)
At 31 December 2010 and 1 January 2011	429,389	2,481,236	(901)	-	40,600	34,105	1,477	-	1,516,228	4,502,134	464,336	4,966,470
Profit for the year	-	-	-	-	-	-	-	-	1,153,624	1,153,624	56,017	1,209,641
Surplus on revaluation of properties	-	-	-	-	-	-	-	11,795	-	11,795	-	11,795
Deferred taxation liability arising from revaluation of properties	-	-	-	-	-	-	-	(2,949)	-	(2,949)	-	(2,949)
Other comprehensive income for the year	-	-	-	-	-	-	-	8,846	-	8,846	-	8,846
Total comprehensive income for the year	-	-	-	-	-	-	-	8,846	1,153,624	1,162,470	56,017	1,218,487
Issue of shares	27,704	304,736	-	-	-	-	-	-	-	332,440	-	332,440
Acquisition of additional interest in subsidiaries	-	-	(10,082)	-	-	-	-	-	-	(10,082)	(334,758)	(344,840)
Acquisition of subsidiaries (note 38(b))	-	-	-	-	-	-	-	-	-	-	(260)	(260)
Disposal of partial interest without loss of control	-	-	(4,690)	-	-	-	-	-	-	(4,690)	4,690	-
Disposal of a subsidiary (note 39)	-	-	-	-	-	-	-	-	-	-	(646)	(646)
Dividend paid to non-controlling shareholders	-	-	-	-	-	-	-	-	-	-	(8,722)	(8,722)
Dividend paid to shareholders of the Company	-	(165,888)	-	-	-	-	-	-	-	(165,888)	-	(165,888)
Recognition of equity-settled share-based payments	-	-	-	2,240	-	-	-	-	-	2,240	-	2,240
Transfer	-	-	-	-	-	6,303	-	-	(6,303)	-	-	-
At 31 December 2011	457,093	2,620,084	(15,673)	2,240	40,600	40,408	1,477	8,846	2,663,549	5,818,624	180,657	5,999,281

### Notes:

- (i) Pursuant to article 16 of the Company's Article of Association, the Company is permitted to pay out final dividend from share premium account.
- (ii) Special reserve arising from the change in Group's ownership interest in subsidiaries without loss of control represents the difference between the consideration paid or received and the adjustment to the non-controlling interests.
- (iii) Share options reserve represents the share-based payment under the Company's share option scheme.
- (iv) The statutory reserves and discretionary reserves relate to subsidiaries in the People's Republic of China (the "PRC") and are non-distributable. Transfers to these reserves are determined by the board of directors or the shareholders' meeting in accordance with the relevant laws and regulations of the PRC. These reserves can be used to offset accumulated losses, expand the scale of production and business and increase capital upon approval from the relevant authorities.
- (v) Revaluation surplus arising from the transfer of owner-occupied property to investment properties at the date of change in use amounted to RMB 11,795,000.

## CONSOLIDATED STATEMENT OF CASH FLOWS

For the year ended 31 December 2011

	2011 RMB'000	2010 RMB'000
<b>OPERATING ACTIVITIES</b>		
Profit before taxation	2,151,840	1,789,678
Adjustments for:		
Change in fair value of investment properties	(182,980)	(320,461)
Recognition of change in fair value of completed properties for sale upon transfer to investment properties	(191,142)	(67,326)
Release of prepaid lease payments	4,824	8,039
Release of premium on prepaid lease payments	6,864	3,997
Release of prepayment	14,533	20,000
Depreciation of property, plant and equipment	21,474	11,058
Gain on disposal of property, plant and equipment	(5)	(77)
Impairment loss recognised in respect of goodwill	1,321	5,375
(Reversal) allowance on bad and doubtful debts, net	(265)	2,937
Interest income	(8,941)	(15,781)
Imputed interest income on non-current interest-free advance to an associate	(537)	(3,593)
Finance costs	108,471	180,131
Net foreign exchange gain	(28,573)	(1,618)
Share of results of associates	(171)	(406)
Share-based payment expenses	2,240	–
Gain on disposal of a subsidiary	(17,589)	–
Gain on disposal of an associate	(3,533)	–
Operating cash flows before movements in working capital	1,877,831	1,611,953
Addition to prepaid lease payments	(148,412)	(700,696)
Increase in land development expenditure	(909,960)	(393,849)
Increase in properties for sale	(1,229,587)	(687,919)
Increase in deposits paid for acquisition of land use rights	–	(763,095)
Increase in trade and other receivables	(141,850)	(338,776)
Decrease in prepayment	17,000	9,802
Increase in prepayment to a related party for construction work	–	(7,500)
Increase in amounts due from customers for contract works	(420)	(12,131)
Increase in trade and other payables	519,205	731,364
Increase (decrease) in deposits received for sale of properties	784,937	(546,175)
Decrease in amounts due from related parties	7,500	–
Increase in amounts due to related parties	2,547	–
Cash generated from (used in) operations	778,791	(1,097,022)
Enterprise income tax ("EIT") paid, net	(218,726)	(129,423)
Land appreciation tax ("LAT") paid	(326,729)	(99,529)
Interest paid	(436,914)	(305,973)
<b>NET CASH USED IN OPERATING ACTIVITIES</b>	<b>(203,578)</b>	<b>(1,631,947)</b>

**CONSOLIDATED STATEMENT OF CASH FLOWS**

For the year ended 31 December 2011

	Notes	2011 RMB'000	2010 RMB'000
<b>INVESTING ACTIVITIES</b>			
Deposits paid for acquisition of a property project		(67,900)	(37,000)
(Increase) decrease in restricted bank deposits		(229,973)	104,551
Settlement of consideration payable		(63,900)	–
Purchases of property, plant and equipment		(155,933)	(73,665)
Additions to investment properties		(273,973)	(330,519)
Acquisition of assets and liabilities through acquisition of subsidiaries (net of cash and cash equivalents acquired)	38(a)	(180,223)	(1,411,326)
Acquisition of business (net of cash and cash equivalents acquired)	38(b)	822	(1,408)
Interest received		8,941	15,781
Investment in an associate		–	(500)
Proceeds from disposal of property, plant and equipment		8,114	471
Disposal of a subsidiary	39	11,691	–
Disposal of an associate		96,000	–
Deposits paid for acquisition of subsidiaries		(8,084)	–
Proceeds from disposal of investment properties		1,450	–
Increase in amounts due from related parties		(3,262)	–
<b>NET CASH USED IN INVESTING ACTIVITIES</b>		<b>(856,230)</b>	<b>(1,733,615)</b>
<b>FINANCING ACTIVITIES</b>			
Net proceeds from the issuance of senior notes	36	–	794,076
Contribution from a non-controlling shareholders		–	2,800
New borrowings raised		2,755,861	3,553,495
Repayment of borrowings		(2,738,576)	(2,190,084)
Dividends paid to shareholders of the Company		(165,888)	(75,100)
Dividend paid to non-controlling shareholders		(8,722)	(3,297)
Repayment to a related party		(100,549)	(310)
Acquisition of additional interest in subsidiaries		(344,840)	(306)
Proceeds from issue of shares		332,440	–
<b>NET CASH (USED IN) FROM FINANCING ACTIVITIES</b>		<b>(270,274)</b>	<b>2,081,274</b>
<b>NET DECREASE IN CASH AND CASH EQUIVALENTS</b>		<b>(1,330,082)</b>	<b>(1,284,288)</b>
<b>CASH AND CASH EQUIVALENTS AT THE BEGINNING OF THE YEAR</b>		<b>2,371,452</b>	<b>3,696,488</b>
Effect of foreign exchange rate changes		(20,015)	(40,748)
<b>CASH AND CASH EQUIVALENTS AT THE END OF THE YEAR, represented by bank balances and cash</b>		<b>1,021,355</b>	<b>2,371,452</b>

# NOTES TO THE CONSOLIDATED FINANCIAL STATEMENTS

For the year ended 31 December 2011

## 1. General

The Company was incorporated in the Cayman Islands on 17 October 2007 as an exempted company with limited liability under the Companies Law of the Cayman Islands. The shares of the Company have been listed on the Main Board of The Stock Exchange of Hong Kong Limited (the “SEHK”) with effect from 25 November 2009. Its parent is Fantasy Pearl International Limited, a limited liability company incorporated in the British Virgin Islands (the “BVI”). Its ultimate holding company is Ice Apex Limited, a limited liability company also incorporated in the BVI. Its ultimate controlling party is Ms. Zeng Jie, Baby. The address of the registered office of the Company is Cricket Square, Hutchins Drive, PO Box 2681, Grand Cayman KY1-1111, Cayman Islands and its principal place of business in Hong Kong is Room 1103, Top Glory Tower, 262 Gloucester Road, Causeway Bay, Hong Kong while its principal place of business in the People’s Republic of China (the “PRC”) is 27/F, Block A, Hailun Complex, No.6021 Shennan Boulevard, Shenzhen 518040, Guangdong Province, the PRC.

The Company acts as an investment holding company. Details of the principal activities of its subsidiaries are set out in note 46.

The consolidated financial statements are presented in Renminbi (“RMB”), which is the functional currency of the Company.

## 2. Application of New and Revised Hong Kong Financial Reporting Standards (“HKFRSs”)

In the current year, the Group has applied the following new and revised HKFRSs issued by the Hong Kong Institute of Certified Public Accountants (“HKICPA”).

Amendments to HKFRSs	Improvements to HKFRSs issued in 2010
HKAS 24 (as revised in 2009)	Related Party Disclosures
Amendments to HKAS 32	Classification of Rights Issues
Amendments to HK (IFRIC) – INT 14	Prepayments of a Minimum Funding Requirement
HK (IFRIC) – INT 19	Extinguishing Financial Liabilities with Equity Instruments

The application of the new and revised HKFRSs in the current year has had no material impact on the Group’s financial performance and positions for the current and prior years and/or on the disclosures set out in these consolidated financial statements.

## NOTES TO THE CONSOLIDATED FINANCIAL STATEMENTS

For the year ended 31 December 2011

### 2. Application of New and Revised Hong Kong Financial Reporting Standards (“HKFRSs”)

(continued)

#### New and revised Standards and Interpretations issued but not yet effective

The Group has not early applied the following new and revised Standards, Amendments or Interpretations that have been issued but are not yet effective.

Amendments to HKFRS 7	Disclosures – Transfers of Financial Assets <sup>1</sup>
	Disclosures – Offsetting Financial Assets and Financial Liabilities <sup>2</sup>
	Mandatory Effective Date of HKFRS 9 and Transition Disclosures <sup>3</sup>
HKFRS 9	Financial Instruments <sup>3</sup>
HKFRS 10	Consolidated Financial Statements <sup>2</sup>
HKFRS 11	Joint Arrangements <sup>2</sup>
HKFRS 12	Disclosure of Interests in Other Entities <sup>2</sup>
HKFRS 13	Fair Value Measurement <sup>2</sup>
Amendments to HKAS 1	Presentation of Items of Other Comprehensive Income <sup>5</sup>
Amendments to HKAS 12	Deferred Tax – Recovery of Underlying Assets <sup>4</sup>
HKAS 19 (as revised in 2011)	Employee Benefits <sup>2</sup>
HKAS 27 (as revised in 2011)	Separate Financial Statements <sup>2</sup>
HKAS 28 (as revised in 2011)	Investments in Associates and Joint Ventures <sup>2</sup>
Amendments to HKAS 32	Offsetting Financial Assets and Financial Liabilities <sup>6</sup>
HK(IFRIC) – Int 20	Stripping Costs in the Production Phase of a Surface Mine <sup>2</sup>

<sup>1</sup> Effective for annual periods beginning on or after 1 July 2011.

<sup>2</sup> Effective for annual periods beginning on or after 1 January 2013.

<sup>3</sup> Effective for annual periods beginning on or after 1 January 2015.

<sup>4</sup> Effective for annual periods beginning on or after 1 January 2012.

<sup>5</sup> Effective for annual periods beginning on or after 1 July 2012.

<sup>6</sup> Effective for annual periods beginning on or after 1 January 2014.

#### HKFRS 9 Financial Instruments

HKFRS 9 issued in 2009 introduces new requirements for the classification and measurement of financial assets. HKFRS 9 amended in 2010 includes the requirements for the classification and measurement of financial liabilities and for derecognition.

Key requirements of HKFRS 9 are described as follows:

- HKFRS 9 requires all recognised financial assets that are within the scope of HKAS 39 *Financial Instruments: Recognition and Measurement* to be subsequently measured at amortised cost or fair value. Specifically, debt investments that are held within a business model whose objective is to collect the contractual cash flows, and that have contractual cash flows that are solely payments of principal and interest on the principal outstanding are generally measured at amortised cost at the end of subsequent accounting periods. All other debt investments and equity investments are measured at their fair values at the end of subsequent reporting periods. In addition, under HKFRS 9, entities may make an irrevocable election to present subsequent changes in the fair value of an equity investment (that is not held for trading) in other comprehensive income, with only dividend income generally recognised in profit or loss.

## 2. Application of New and Revised Hong Kong Financial Reporting Standards (“HKFRSs”)

(continued)

### HKFRS 9 Financial Instruments (continued)

- The most significant effect of HKFRS 9 regarding the classification and measurement of financial liabilities relates to the presentation of changes in the fair value of a financial liability (designated as at fair value through profit or loss) attributable to changes in the credit risk of that liability. Specifically, under HKFRS 9, for financial liabilities that are designated as at fair value through profit or loss, the amount of change in the fair value of the financial liability that is attributable to changes in the credit risk of that liability is presented in other comprehensive income, unless the recognition of the effects of changes in the liability’s credit risk in other comprehensive income would create or enlarge an accounting mismatch in profit or loss. Changes in fair value attributable to a financial liability’s credit risk are not subsequently reclassified to profit or loss. Previously, under HKAS 39, the entire amount of the change in the fair value of the financial liability designated as at fair value through profit or loss was presented in profit or loss.

The directors anticipate that the adoption of HKFRS 9 in the future will not have significant impact on amounts reported in respect of the Group’s financial assets and financial liabilities.

### New and revised Standards on consolidation, joint arrangements, associates and disclosures

In June 2011, a package of five standards on consolidation, joint arrangements, associates and disclosures was issued, including HKFRS 10, HKFRS 11, HKFRS 12, HKAS 27 (as revised in 2011) and HKAS 28 (as revised in 2011).

Key requirements of these five standards are described below:

HKFRS 10 replaces the parts of HKAS 27 *Consolidated and Separate Financial Statements* that deal with consolidated financial statements and HK (SIC)-Int 12 *Consolidation – Special Purpose Entities*. HKFRS 10 includes a new definition of control that contains three elements: (a) power over an investee, (b) exposure, or rights, to variable returns from its involvement with the investee, and (c) the ability to use its power over the investee to affect the amount of the investor’s returns. Extensive guidance has been added in HKFRS 10 to deal with complex scenarios.

HKFRS 11 replaces HKAS 31 *Interests in Joint Ventures* and HK (SIC)-Int 13 *Jointly Controlled Entities – Non-Monetary Contributions by Venturers*. HKFRS 11 deals with how a joint arrangement of which two or more parties have joint control should be classified. Under HKFRS 11, joint arrangements are classified as joint operations or joint ventures, depending on the rights and obligations of the parties to the arrangements. In contrast, under HKAS 31, there are three types of joint arrangements: jointly controlled entities, jointly controlled assets and jointly controlled operations.

In addition, joint ventures under HKFRS 11 are required to be accounted for using the equity method of accounting, whereas jointly controlled entities under HKAS 31 can be accounted for using the equity method of accounting or proportionate accounting.

HKFRS 12 is a disclosure standard and is applicable to entities that have interests in subsidiaries, joint arrangements, associates and/or unconsolidated structured entities. In general, the disclosure requirements in HKFRS 12 are more extensive than those in the current standards.

## NOTES TO THE CONSOLIDATED FINANCIAL STATEMENTS

For the year ended 31 December 2011

### 2. Application of New and Revised Hong Kong Financial Reporting Standards (“HKFRSs”)

(continued)

#### **New and revised Standards on consolidation, joint arrangements, associates and disclosures** (continued)

These five standards are effective for annual periods beginning on or after 1 January 2013. Earlier application is permitted provided that all of these five standards are applied early at the same time.

The directors anticipate that these five standards will be adopted in the Group’s consolidated financial statements for the annual period beginning 1 January 2013. The application of these five standards may have significant impact on amounts reported in the consolidated financial statements. However, the directors have not yet performed a detailed analysis of the impact of the application of these five standards and have not yet quantified the extent of the impact.

#### **HKFRS 13 Fair Value Measurement**

HKFRS 13 establishes a single source of guidance for fair value measurements and disclosures about fair value measurements. The Standard defines fair value, establishes a framework for measuring fair value, and requires disclosures about fair value measurements. The scope of HKFRS 13 is broad; it applies to both financial instrument items and non-financial instrument items for which other HKFRSs require or permit fair value measurements and disclosures about fair value measurements, except in specified circumstances. In general, the disclosure requirements in HKFRS 13 are more extensive than those in the current standards. For example, quantitative and qualitative disclosures based on the three-level fair value hierarchy currently required for financial instruments only under HKFRS 7 *Financial Instruments: Disclosures* will be extended by HKFRS 13 to cover all assets and liabilities within its scope.

HKFRS 13 is effective for annual periods beginning on or after 1 January 2013, with earlier application permitted.

The directors anticipate that HKFRS 13 will be adopted in the Group’s consolidated financial statements for the annual period beginning 1 January 2013 and that the application of the new Standard may affect the amounts reported in the consolidated financial statements and result in more extensive disclosures in the consolidated financial statements.

#### **Amendments to HKAS 1 Presentation of Items of Other Comprehensive Income**

The amendments to HKAS 1 retain the option to present profit or loss and other comprehensive income in either a single statement or in two separate but consecutive statements. However, the amendments to HKAS 1 require additional disclosures to be made in the other comprehensive income section such that items of other comprehensive income are grouped into two categories: (a) items that will not be reclassified subsequently to profit or loss; and (b) items that may be reclassified subsequently to profit or loss when specific conditions are met. Income tax on items of other comprehensive income is required to be allocated on the same basis.

The amendments to HKAS 1 are effective for annual periods beginning on or after 1 July 2012. The presentation of items of other comprehensive income will be modified accordingly when the amendments are applied in the future accounting periods.



## 2. Application of New and Revised Hong Kong Financial Reporting Standards (“HKFRSs”)

(continued)

### Amendments to HKAS 12 Deferred Tax – Recovery of Underlying Assets

The amendments to HKAS 12 provide an exception to the general principles in HKAS 12 that the measurement of deferred tax assets and deferred tax liabilities should reflect the tax consequences that would follow from the manner in which the entity expects to recover the carrying amount of an asset. Specifically, under the amendments, investment properties that are measured using the fair value model in accordance with HKAS 40 *Investment Property* are presumed to be recovered through sale for the purposes of measuring deferred taxes, unless the presumption is rebutted in certain circumstances.

The amendments to HKAS 12 are effective for annual periods beginning on or after 1 January 2012. The directors anticipate that the application of the amendments to HKAS 12 in future accounting periods will result in adjustments to the amounts of deferred tax liabilities recognised in prior years regarding the Group’s investment properties of which the carrying amounts are presumed to be recovered through sale. However, the directors have not yet performed a detailed analysis of the impact of the application of the amendments to HKAS 12 and hence have not yet quantified the extent of the impact.

## 3. Significant Accounting Policies

The consolidated financial statements have been prepared in accordance with Hong Kong Financial Reporting Standards issued by the HKICPA. In addition, the consolidated financial statements include applicable disclosures required by the Rules Governing the Listing of Securities on The Stock Exchange of Hong Kong Limited and by the Hong Kong Companies Ordinance.

The consolidated financial statements have been prepared on the historical cost basis, except for certain properties and financial instruments that are measured at fair values, as explained in the accounting policies set out below. Historical cost is generally based on the fair value of the consideration given in exchange for goods.

The significant accounting policies are set out below.

### Basis of consolidation

The consolidated financial statements incorporate the financial statements of the Company and entities controlled by the Company (its subsidiaries). Control is achieved where the Company has the power to govern the financial and operating policies of an entity so as to obtain benefits from its activities.

The results of subsidiaries acquired or disposed of during the year are included in the consolidated statement of comprehensive income from the effective date of acquisition and up to the effective date of disposal, as appropriate.

Where necessary, adjustments are made to the financial statements of subsidiaries to bring their accounting policies into line with those used by other members of the Group.

All intra-group transactions, balances, income and expenses are eliminated on consolidation.

Non-controlling interests in subsidiaries are presented separately from the Group’s equity therein.

## NOTES TO THE CONSOLIDATED FINANCIAL STATEMENTS

For the year ended 31 December 2011

### 3. Significant Accounting Policies (continued)

#### Basis of consolidation (continued)

##### *Allocation of total comprehensive income to non-controlling interests*

Total comprehensive income and expense of a subsidiary is attributed to the owners of the Company and to the non-controlling interests even if this results in the non-controlling interests having a deficit balance (effective from 1 January 2010 onwards).

##### *Changes in the Group's ownership interests in existing subsidiaries*

Changes in the Group's ownership interests in subsidiaries that do not result in the Group losing control over the subsidiaries are accounted for as equity transactions. The carrying amounts of the Group's interests and the non-controlling interests are adjusted to reflect the changes in their relative interests in the subsidiaries. Any difference between the amount by which the non-controlling interests are adjusted and the fair value of the consideration paid or received is recognised directly in equity and attributed to owners of the Company.

When the Group loses control of a subsidiary, it (i) derecognises the assets (including any goodwill) and liabilities of the subsidiary at their carrying amounts at the date when control is lost, (ii) derecognises the carrying amount of any non-controlling interests in the former subsidiary at the date when control is lost (including any components of other comprehensive income attributable to them), and (iii) recognises the aggregate of the fair value of the consideration received and the fair value of any retained interest, with any resulting difference being recognised as a gain or loss in profit or loss attributable to the Group. When assets of the subsidiary are carried at revalued amounts or fair values and the related cumulative gain or loss has been recognised in other comprehensive income and accumulated in equity, the amounts previously recognised in other comprehensive income and accumulated in equity are accounted for as if the Group had directly disposed of the related assets (i.e. reclassified to profit or loss or transferred directly to retained earnings as specified by applicable HKFRSs). The fair value of any investment retained in the former subsidiary at the date when control is lost is regarded as the fair value on initial recognition for subsequent accounting under HKAS 39 *Financial Instruments: Recognition and Measurement* or, when applicable, the cost on initial recognition of an investment in an associate or a jointly controlled entity.

#### Business combinations

Acquisitions of businesses are accounted for using the acquisition method. The consideration transferred in a business combination is measured at fair value, which is calculated as the sum of the acquisition-date fair values of the assets transferred by the Group, liabilities incurred by the Group to the former owners of the acquiree and the equity interests issued by the Group in exchange for control of the acquiree. Acquisition-related costs are generally recognised in profit or loss as incurred.

### 3. Significant Accounting Policies (continued)

#### Business combinations (continued)

At the acquisition date, the identifiable assets acquired and the liabilities assumed are recognised at their fair value at the acquisition date, except that:

- deferred tax assets or liabilities and liabilities or assets related to employee benefit arrangements are recognised and measured in accordance with HKAS 12 *Income Taxes* and HKAS 19 *Employee Benefits* respectively;
- liabilities or equity instruments related to share-based payment transactions of the acquiree or the replacement of an acquiree's share-based payment transactions with share-based payment transactions of the Group are measured in accordance with HKFRS 2 *Share-based Payment* at the acquisition date (see the accounting policy below); and
- assets (or disposal groups) that are classified as held for sale in accordance with HKFRS 5 *Non-current Assets Held for Sale and Discontinued Operations* are measured in accordance with that Standard.

Goodwill is measured as the excess of the sum of the consideration transferred, the amount of any non-controlling interests in the acquiree, and the fair value of the acquirer's previously held equity interest in the acquiree (if any) over the net of the acquisition-date amounts of the identifiable assets acquired and the liabilities assumed. If, after re-assessment, the net of the acquisition-date amounts of the identifiable assets acquired and liabilities assumed exceeds the sum of the consideration transferred, the amount of any non-controlling interests in the acquiree and the fair value of the acquirer's previously held interest in the acquiree (if any), the excess is recognised immediately in profit or loss as a bargain purchase gain.

Non-controlling interests that are present ownership interests and entitle their holders to a proportionate share of the entity's net assets in the event of liquidation may be initially measured either at fair value or at the non-controlling interests' proportionate share of the recognised amounts of the acquiree's identifiable net assets. The choice of measurement basis is made on a transaction-by-transaction basis. Other types of non-controlling interests are measured at their fair value or, when applicable, on the basis specified in another Standard.

#### Property, plant and equipment

Property, plant and equipment including buildings held for use in the production or supply of goods or services, or for administrative purposes (other than properties under construction as described below) are stated in the consolidated statement of financial position at cost less subsequent accumulated depreciation and accumulated impairment losses, if any.

Depreciation is recognised so as to write off the cost of items of property, plant and equipment other than construction in progress less their residual values over their estimated useful lives, using the straight-line method. The estimated useful lives, residual values and depreciation method are reviewed at the end of each reporting period, with the effect of any changes in estimate accounted for on a prospective basis.

## NOTES TO THE CONSOLIDATED FINANCIAL STATEMENTS

For the year ended 31 December 2011

### 3. Significant Accounting Policies (continued)

#### Property, plant and equipment (continued)

Properties in the course of construction for production, supply or administrative purposes are carried at cost, less any recognised impairment loss. Costs include professional fees and, for qualifying assets, borrowing costs capitalised in accordance with the Group's accounting policy. Such properties are classified to the appropriate categories of property, plant and equipment when completed and ready for intended use. Depreciation of these assets, on the same basis as other property assets, commences when the assets are ready for their intended use.

If an item of property, plant and equipment becomes an investment property because its use has changed as evidenced by end of owner-occupation, any difference between the carrying amount and the fair value of that item at the date of transfer is recognised in other comprehensive income and accumulated in property revaluation reserve. On the subsequent sale or retirement of the asset, the relevant revaluation reserve will be transferred directly to retained profits.

An item of property, plant and equipment is derecognised upon disposal or when no future economic benefits are expected to arise from the continued use of the asset. Any gain or loss arising on the disposal or retirement of an item of property, plant and equipment is determined as the difference between the sales proceeds and the carrying amount of the asset and is recognised in profit or loss.

#### *Buildings under development for future owner-occupied purpose*

When buildings are in the course of development for production or for administrative purposes, the amortisation of prepaid lease payments provided during the construction period is included as part of costs of buildings under construction. Buildings under construction are carried at cost, less any identified impairment losses. Depreciation of buildings commences when they are available for use (i.e. when they are in the location and condition necessary for them to be capable of operating in the manner intended by management).

#### Investment properties

Investment properties are properties held to earn rentals and/or for capital appreciation including properties under construction for such purposes.

Investment properties are initially measured at cost, including any directly attributable expenditure. Subsequent to initial recognition, investment properties are measured at their fair values using the fair value model. Gains or losses arising from changes in the fair value of investment property are included in profit or loss for the period in which they arise.

Construction costs incurred for investment properties under construction are capitalised as part of the carrying amount of the investment properties under construction.

### 3. Significant Accounting Policies (continued)

#### Investment properties (continued)

Property that is being constructed or developed for future use as investment property is classified as investment property. If the fair value cannot be reliably determined, the investment property under development will be measured at cost until such time as fair value can be determined or construction is completed.

An investment property is derecognised upon disposal or when the investment property is permanently withdrawn from use and no future economic benefits are expected from its disposals. Any gain or loss arising on derecognition of the asset (calculated as the difference between the net disposal proceeds and the carrying amount of the asset) is included in the profit or loss in the period in which the item is derecognised.

#### Interests in associates

An associate is an entity over which the Group has significant influence and that is neither a subsidiary nor an interest in a joint venture. Significant influence is the power to participate in the financial and operating policy decisions of the investee but is not control or joint control over those policies.

The results and assets and liabilities of associates are incorporated in these consolidated financial statements using the equity method of accounting. Under the equity method, investments in associates are initially recognised in the consolidated statement of financial position at cost and adjusted thereafter to recognise the Group's share of the profit or loss and other comprehensive income of the associates. When the Group's share of losses of an associate exceeds the Group's interest in that associate (which includes any long-term interests that, in substance, form part of the Group's net investment in the associate), the Group discontinues recognising its share of further losses. Additional losses are recognised only to the extent that the Group has incurred legal or constructive obligations or made payments on behalf of the associate.

Any excess of the cost of acquisition over the Group's share of the net fair value of the identifiable assets, liabilities and contingent liabilities of an associate recognised at the date of acquisition is recognised as goodwill, which is included within the carrying amount of the investment.

Any excess of the Group's share of the net fair value of the identifiable assets, liabilities and contingent liabilities over the cost of acquisition, after reassessment, is recognised immediately in profit or loss.

The requirements of HKAS 39 are applied to determine whether it is necessary to recognise any impairment loss with respect to the Group's investment in an associate. When necessary, the entire carrying amount of the investment (including goodwill) is tested for impairment in accordance with HKAS 36 *Impairment of Assets* as a single asset by comparing its recoverable amount (higher of value in use and fair value less costs to sell) with its carrying amount, any impairment loss recognised forms part of the carrying amount of the investment. Any reversal of that impairment loss is recognised in accordance with HKAS 36 to the extent that the recoverable amount of the investment subsequently increases.

When a group entity transacts with its associate, profits and losses resulting from the transactions with the associate are recognised in the Group's consolidated financial statements only to the extent of interests in the associate that are not related to the Group.

## NOTES TO THE CONSOLIDATED FINANCIAL STATEMENTS

For the year ended 31 December 2011

### 3. Significant Accounting Policies (continued)

#### Goodwill

Goodwill arising on an acquisition of a business is carried at cost less any accumulated impairment losses and is presented separately in the consolidated statement of financial position.

For the purposes of impairment testing, goodwill arising from an acquisition is allocated to each of the relevant cash-generating units (or groups of cash generating units) that is expected to benefit from the synergies of the acquisition.

A cash-generating unit to which goodwill has been allocated is tested for impairment annually, or more frequent whenever there is indication that the unit may be impaired. For goodwill arising on an acquisition in a reporting period, the cash-generating unit to which goodwill has been allocated is tested for impairment before the end of that reporting period. If the recoverable amount of the cash-generating unit is less than the carrying amount of the unit, the impairment loss is allocated first to reduce the carrying amount of any goodwill allocated to the unit and then to the other assets of the unit pro-rata on the basis of the carrying amount of each asset in the unit. Any impairment loss for goodwill is recognised directly in profit or loss in the consolidated statement of comprehensive income. An impairment loss recognised for goodwill is not reversed in a subsequent periods.

On subsequent disposal of the relevant cash-generating unit, the attributable amount of goodwill is included in the determination of the amount of profit or loss on disposal.

#### Land development expenditure

Land development expenditure is stated at the lower of cost and net realisable value. The cost includes expenditure directly attributable to the development of relevant projects such as road construction, demolition, resettlement work and borrowing cost.

#### Properties for sale

Completed properties and properties under development for sale in the ordinary course of business are included in current assets and stated at the lower of cost and net realisable value. Cost includes the cost of land, development expenditure, borrowing costs capitalised in accordance with the Group's accounting policy, and other attributable expenses.

The Group transfers a property from inventories to investment property when there is a change of intention to hold the property to earn rentals or/and for capital appreciation rather than for sale in the ordinary course of business, which is evidenced by the commencement of an operating lease to another party. Any difference between the fair value of the property at the date of transfer and its previous carrying amount is recognised in profit or loss.

### 3. Significant Accounting Policies (continued)

#### **Installation contracts**

Where the outcome of the installation contract can be estimated reliably, revenue and costs are recognised by reference to the stage of completion of the contract activity at the end of the reporting period, as measured by reference to the proportion that billings agreed with the customer to date relative to the estimated total revenue for each contract. Variations in contract work, claims and incentive payments are included to the extent that the amount can be measured reliably and its receipt is considered probable.

Where the outcome of a contract cannot be estimated reliably, contract revenue is recognised to the extent of contract costs incurred that it is probable will be recoverable. Contract costs are recognised as expenses in the period in which they are incurred.

When it is probable that total contract costs will exceed total contract revenue, the expected loss is recognised as an expense immediately.

Where contract costs incurred to date plus recognised profits less recognised losses exceed progress billings, the surplus is shown as amounts due from customers for contract works. For contracts where progress billings exceed contract costs incurred to date plus recognised profits less recognised losses, the surplus is shown as amounts due to customers for contract works. Amounts received before the related work is performed are included in the consolidated statement of financial position, as a liability, as advances received included in other payables. Amounts billed for work performed but not yet paid by the customer are included in the consolidated statement of financial position under trade and other receivables.

#### **Financial instruments**

Financial assets and financial liabilities are recognised in the consolidated statement of financial position when a group entity becomes a party to the contractual provisions of the instrument.

Financial assets and financial liabilities are initially measured at fair value. Transaction costs that are directly attributable to the acquisition or issue of financial assets and financial liabilities (other than financial assets and financial liabilities at fair value through profit or loss) are added to or deducted from the fair values of the financial assets or financial liabilities, as appropriate, on initial recognition. Transaction costs directly attributable to the acquisition of financial assets or financial liabilities at fair value through profit or loss are recognised immediately in profit or loss.

#### **Financial assets**

The Group's financial assets are generally classified as loans and receivables. The classification depends on the nature and purpose of the financial assets and is determined at the time of initial recognition.

## NOTES TO THE CONSOLIDATED FINANCIAL STATEMENTS

For the year ended 31 December 2011

### 3. Significant Accounting Policies (continued)

#### Financial instruments (continued)

##### *Financial assets (continued)*

##### *Effective interest method*

The effective interest method is a method of calculating the amortised cost of a financial asset and of allocating interest income over the relevant period. The effective interest rate is the rate that exactly discounts estimated future cash receipts (including all fees paid or received that form an integral part of the effective interest rate, transaction costs and other premiums or discounts) through the expected life of the financial asset, or, where appropriate, a shorter period to the net carrying amount on initial recognition.

Interest income is recognised on an effective interest basis for debt instruments.

##### *Loans and receivables*

Loans and receivables are non-derivative financial assets with fixed or determinable payments that are not quoted in an active market. Subsequent to initial recognition, loans and receivables (including advance to an associate, deposits paid for acquisition of land use rights, subsidiaries and a property project, trade and other receivables, restricted bank deposits and bank balances and cash) are carried at amortised cost using the effective interest method, less any identified impairment losses (see accounting policy on impairment of financial assets below).

##### *Impairment of financial assets*

Financial assets are assessed for indicators of impairment at the end of the reporting period. Financial assets are considered to be impaired where there is objective evidence that, as a result of one or more events that occurred after the initial recognition of the financial asset, the estimated future cash flows of the financial assets have been affected.

Objective evidence of impairment could include:

- significant financial difficulty of the issuer or counterparty; or
- breach of contract, such as default or delinquency in interest and principal payments; or
- it becoming probable that the borrower will enter bankruptcy or financial re-organisation; or
- disappearance of an active market for that financial asset because of financial difficulties.



### 3. Significant Accounting Policies (continued)

#### Financial instruments (continued)

##### *Financial assets (continued)*

##### *Impairment of financial assets (continued)*

For certain categories of financial asset, such as trade and other receivables, assets that are assessed not to be impaired individually are subsequently assessed for impairment on a collective basis. Objective evidence of impairment for a portfolio of receivables could include the Group's past experience of collecting payments, an increase in the number of delayed payments in the portfolio past the average credit period, observable changes in national or local economic conditions that correlate with default on receivables.

The amount of the impairment loss recognised is the difference between the asset's carrying amount and the present value of the estimated future cash flows discounted at the financial asset's original effective interest rate.

The carrying amount of the financial asset is reduced by the impairment loss directly with the exception of trade and other receivables, where the carrying amount is reduced through the use of an allowance account. Changes in the carrying amount of the allowance account are recognised in profit or loss. When trade and other receivables are considered uncollectible, it is written off against the allowance account. Subsequent recoveries of amounts previously written off are credited to profit or loss.

##### *Financial liabilities and equity instruments*

Financial liabilities and equity instruments issued by a group entity are classified as either financial liabilities or as equity in accordance with the substance of the contractual arrangements entered into and the definitions of a financial liability and an equity instrument.

##### *Effective interest method*

The effective interest method is a method of calculating the amortised cost of a financial liability and of allocating interest expense over the relevant period. The effective interest rate is the rate that exactly discounts estimated future cash payments (including all fees paid or received that form an integral part of the effective interest rate, transaction costs and other premiums or discounts) through the expected life of the financial liability, or, where appropriate, a shorter period, to the net carrying amount on initial recognition.

Interest expense is recognised on an effective interest basis.

##### *Other financial liabilities*

Other financial liabilities (including trade and other payables, amounts due to related parties, borrowings and senior notes) are subsequently measured at amortised cost, using the effective interest method.

## NOTES TO THE CONSOLIDATED FINANCIAL STATEMENTS

For the year ended 31 December 2011

### 3. Significant Accounting Policies (continued)

#### Financial instruments (continued)

##### *Senior notes*

Senior notes issued by the Group that contain both liability and early redemption option (which is not closely related to the host contract) are classified separately into respective items on initial recognition. At the date of issue, both the liability and early redemption option components are recognised at fair value.

In subsequent periods, the liability component of the senior notes is carried at amortised cost using the effective interest method. The early redemption option is measured at fair value with changes in fair value recognised in profit or loss.

Transaction costs that relate to the issue of the senior notes are allocated to the liability and early redemption option components in proportion to their relative fair values. Transaction costs relating to the early redemption option are charged to profit or loss immediately. Transaction costs relating to the liability component are included in the carrying amount of the liability portion and amortised over the period of the senior notes using the effective interest method.

##### *Equity instruments*

An equity instrument is any contract that evidences a residual interest in the assets of the Group after deducting all of its liabilities. Equity instruments issued by the Group are recognised at the proceeds received, net of direct issue costs.

##### *Embedded derivatives*

Derivatives embedded in non-derivative host contracts are treated as separate derivatives when their risks and characteristics are not closely related to those of the host contracts and the host contracts are not measured at fair value with changes in fair value recognised in profit or loss.

##### *Financial guarantee contracts*

A financial guarantee contract is a contract that requires the issuer to make specified payments to reimburse the holder for a loss it incurs because a specified debtor fails to make payment when due in accordance with the original or modified terms of a debt instrument.

A financial guarantee contract issued by the Group and not designated at fair value through profit or loss is recognised initially at its fair value less transaction costs that are directly attributable to the issue of the financial guarantee contract. Subsequent to initial recognition, the Group measures the financial guarantee contract at the higher of: (i) the amount of obligation under the contract, as determined in accordance with HKAS 37 *Provisions, Contingent Liabilities and Contingent Assets*, and (ii) the amount initially recognised less, when appropriate, cumulative amortisation recognised in accordance with the revenue recognition policy.

### 3. Significant Accounting Policies (continued)

#### Financial instruments (continued)

##### *Derecognition*

The Group derecognises a financial asset only when the contractual rights to the cash flows from the asset expire, or when it transfers the financial asset and substantially all the risks and rewards of ownership of the asset to another entity. If the Group neither transfers nor retains substantially all the risks and rewards of ownership and continues to control the transferred asset, the Group continues to recognise the asset to the extent of its continuing involvement and recognises an associated liability. If the Group retains substantially all the risks and rewards of ownership of a transferred financial asset, the Group continues to recognise the financial asset and also recognises a collateralised borrowing for the proceeds received.

On derecognition of a financial asset in its entirety, the difference between the asset's carrying amount and the sum of the consideration received and receivable and the cumulative gain or loss that had been recognised in other comprehensive income and accumulated in equity is recognised in profit or loss.

The Group derecognises financial liabilities when, and only when, the Group's obligations are discharged, cancelled or expire. The difference between the carrying amount of the financial liability derecognised and the consideration paid and payable is recognised in profit or loss.

Impairment losses on tangible assets other than goodwill (see accounting policy in respect of goodwill above)

At the end of the reporting period, the Group reviews the carrying amounts of its tangible assets to determine whether there is any indication that those assets have suffered an impairment loss. If any such indication exists, the recoverable amount of the asset is estimated in order to determine the extent of the impairment loss, if any. When it is not possible to estimate the recoverable amount of an individual asset, the Group estimates the recoverable amount of the cash-generating unit to which the asset belongs. Where a reasonable and consistent basis of allocation can be identified, corporate assets are also allocated to individual cash-generating units, or otherwise they are allocated to the smallest group of cash-generating units for which a reasonable and consistent allocation basis can be identified.

Recoverable amount is the higher of fair value less costs to sell and value in use. In assessing value in use, the estimated future cash flows are discounted to their present value using a pre-tax discount rate that reflects current market assessments of the time value of money and the risks specific to the asset for which the estimates of future cash flows have not been adjusted.

If the recoverable amount of an asset (or a cash-generating unit) is estimated to be less than its carrying amount, the carrying amount of the asset (or a cash-generating unit) is reduced to its recoverable amount. An impairment loss is recognised immediately in profit or loss, unless the relevant asset is carried at a revalued amount under another standard, in which case the impairment loss is treated as a revaluation decrease under that standard.

## NOTES TO THE CONSOLIDATED FINANCIAL STATEMENTS

For the year ended 31 December 2011

### 3. Significant Accounting Policies (continued)

#### Financial instruments (continued)

##### *Derecognition* (continued)

Where an impairment loss subsequently reverses, the carrying amount of the asset is increased to the revised estimate of its recoverable amount, but so that the increased carrying amount does not exceed the carrying amount that would have been determined had no impairment loss been recognised for the asset (or a cash-generating unit) in prior years. A reversal of an impairment loss is recognised as income immediately, unless the relevant asset is carried at a revalued amount under another standard, in which case the reversal of the impairment loss is treated as a revaluation increase under that standard.

##### Revenue recognition

Revenue is measured at the fair value of the consideration received or receivable and represents amounts receivable for properties sold and services provided in the normal course of business, net of discounts and sales related taxes.

##### *Sales of properties*

Revenue from sales of properties in the ordinary course of business is recognised when the respective properties have been completed and delivered to the buyers. Deposits and instalments received from purchasers prior to meeting the above criteria for revenue recognition are included in the consolidated statement of financial position under current liabilities.

When the completed properties are sold in exchange for dissimilar goods or services, the exchange is regarded as a transaction which generates revenue. The revenue is measured at the fair value of the goods or services received, adjusted by the amount of any cash or cash equivalents transferred.

##### *Agency fee, service income, management fee, parking fee and consultation fee*

Agency fee, service income, management fee, parking fee and consultation fee are recognised when services are provided.

##### *Contract revenue*

Contract revenue from installation contract is recognised when the outcome of the contract can be estimated reliably and the stage of completion at the end of reporting period can be measured reliably. Revenue from construction contracts is recognised on the percentage of completion method, measured by reference to the proportion that billings agreed with the customer to date relative to the estimated total revenue for each contract. When the outcome of a construction contract cannot be estimated reliably, revenue is recognised only to the extent of contract cost incurred that it is probable to be recoverable.

##### *Hotel operation*

Revenue from hotel accommodation, hotel management and related services, food and beverage sales and other ancillary services is recognised when the services are rendered.

### 3. Significant Accounting Policies (continued)

#### Revenue recognition (continued)

##### *Interest income*

Interest income from a financial asset is recognised when it is probable that the economic benefits will flow to the Group and the amount of income can be measured reliably. Interest income is accrued on a time basis, by reference to the principal outstanding and at the effective interest rate applicable, which is the rate that exactly discounts estimated future cash receipts through the expected life of the financial asset to that asset's net carrying amount on initial recognition.

##### **Government grants**

Government grants are not recognised until there is reasonable assurance that the Group will comply with the conditions attaching to them and that the grants will be received.

Government grants are recognised in profit or loss on a systematic basis over the periods in which the Group recognises as expenses the related costs for which the grants are intended to compensate.

Government grants that are receivable as compensation for expenses or losses already incurred or for the purpose of giving immediate financial support to the Group with no future related costs are recognised in profit or loss in the period in which they become receivable.

##### **Borrowing costs**

Borrowing costs directly attributable to the acquisition, construction or production of qualifying assets, which are assets that necessarily take a substantial period of time to get ready for their intended use or sale, are added to the cost of those assets until such time as the assets are substantially ready for their intended use or sale.

All other borrowing costs are recognised in profit or loss in the period in which they are incurred.

##### **Leasing**

Leases are classified as finance leases whenever the terms of the lease transfer substantially all the risks and rewards of ownership to the lessee. All other leases are classified as operating leases.

##### *The Group as lessor*

Rental income from operating leases is recognised in profit or loss on a straight-line basis over the term of the relevant lease.

##### *The Group as lessee*

Operating lease payments are recognised as an expense on a straight-line basis over the lease term, except where another systematic basis is more representative of the time pattern in which economic benefits from the leased asset are consumed.

## NOTES TO THE CONSOLIDATED FINANCIAL STATEMENTS

For the year ended 31 December 2011

### 3. Significant Accounting Policies (continued)

#### Leasing (continued)

##### *The Group as lessee (continued)*

In the event that lease incentives are received to enter into operating leases, such incentives are recognised as a liability. The aggregate benefit of incentives is recognised as a reduction of rental expense on a straight-line basis, except where another systematic basis is more representative of the time pattern in which economic benefits from the leased asset are consumed.

##### *Leasehold land and building*

When a lease includes both land and building elements, the Group assesses the classification of each element as a finance or an operating lease separately based on the assessment as to whether substantially all the risks and rewards incidental to ownership of each element have been transferred to the Group, unless it is clear that both elements are operating leases in which case the entire lease is classified as an operating lease. Specifically, the minimum lease payments (including any lump-sum upfront payments) are allocated between the land and the building elements in proportion to the relative fair values of the leasehold interests in the land element and building element of the lease at the inception of the lease.

To the extent the allocation of the lease payments can be made reliably, interest in leasehold land that is accounted for as an operating lease is presented as “prepaid lease payments” in the consolidated statement of financial position and is amortised over the lease term on a straight-line basis except for those that are classified and accounted for as investment properties under the fair value model. When the lease payments cannot be allocated reliably between the land and building elements, the entire lease is generally classified as a finance lease and accounted for as property, plant and equipment.

##### *Prepaid lease payments*

The prepaid lease payments represent upfront payments for land use rights for the purpose of development of properties for sale or for use in the production or supply of goods or services, and are initially recognised at cost and released to profit or loss over the remaining lease term on a straight-line basis. The prepaid lease payments in respect of development of projects for sale whereby the construction work is expected to complete beyond normal operating cycle are classified under non-current assets.

##### *Premium on prepaid lease payments*

The premium on prepaid lease payments represent the excess of the consideration paid over the carrying amount of the prepaid lease payments in respect of leasehold lands in the PRC acquired through acquisition of subsidiaries and released to profit or loss over the remaining lease term on a straight-line basis. The premium on prepaid lease payments in respect of projects whereby the construction work is expected to complete beyond normal operating cycle are classified under non-current assets.

### 3. Significant Accounting Policies (continued)

#### Taxation

Income tax expense represents the sum of the tax currently payable and deferred tax.

The tax currently payable is based on taxable profit for the year. Taxable profit differs from the profit as reported in the consolidated statement of comprehensive income because it excludes items of income or expense that are taxable or deductible in other years and it further excludes items that are never taxable or deductible. The Group's liability for current tax is calculated using tax rates that have been enacted or substantively enacted by the end of the reporting period.

Deferred tax is recognised on differences between the carrying amounts of assets and liabilities in the consolidated financial statements and the corresponding tax base used in the computation of taxable profit. Deferred tax liabilities are generally recognised for all taxable temporary differences. Deferred tax assets are generally recognised to the extent that it is probable that taxable profits will be available against which those deductible temporary differences can be utilised. Such assets and liabilities are not recognised if the temporary difference arises from goodwill or from the initial recognition (other than in a business combination) of other assets and liabilities in a transaction that affects neither the taxable profit nor the accounting profit.

Deferred tax liabilities are recognised for taxable temporary differences associated with investments in subsidiaries and associates, except where the Group is able to control the reversal of the temporary difference and it is probable that the temporary difference will not reverse in the foreseeable future. Deferred tax assets arising from deductible temporary differences associated with such investments are only recognised to the extent that it is probable that there will be sufficient taxable profits against which to utilise the benefits of the temporary differences and they are expected to reverse in the foreseeable future.

The carrying amount of deferred tax assets is reviewed at the end of the reporting period and reduced to the extent that it is no longer probable that sufficient taxable profits will be available to allow all or part of the asset to be recovered.

Deferred tax assets and liabilities are measured at the tax rates that are expected to apply in the period in which the liability is settled or the asset is realised, based on tax rate (and tax laws) that have been enacted or substantively enacted by the end of the reporting period.

The measurement of deferred tax liabilities and assets reflects the tax consequences that would follow from the manner in which the Group expects, at the end of the reporting period, to recover or settle the carrying amount of its assets and liabilities.

Current and deferred tax is recognised in profit or loss, except when it relates to items that are recognised in other comprehensive income or directly in equity, in which case, the current and deferred tax are also recognised in other comprehensive income or directly in equity respectively.

## NOTES TO THE CONSOLIDATED FINANCIAL STATEMENTS

For the year ended 31 December 2011

### 3. Significant Accounting Policies (continued)

#### Retirement benefit costs

Payments to state-managed retirement benefit scheme and the Mandatory Provident Fund Scheme are recognised as an expense when employees have rendered service entitling them to the contributions.

#### Foreign currencies

In preparing the financial statements of each individual group entity, transactions in currencies other than the functional currency of the entity (foreign currencies) are recorded in the respective functional currency (i.e. the currency of the primary economic environment in which the entity operates) at the rates of exchange prevailing on the dates of transactions. At the end of the reporting period, monetary items denominated in foreign currencies are retranslated at the rates prevailing at that date. Non-monetary items that are measured in terms of historical cost in a foreign currency are not retranslated.

Exchange differences arising on the settlement of monetary items, and on the retranslation of monetary items, are included in profit or loss in the period in which they arise.

#### Share-based payment transactions

##### *Equity-settled share-based payment transactions*

The fair value of services received determined by reference to the fair value of share options granted at the grant date is expensed on a straight-line basis over the vesting period, with a corresponding increase in equity (share options reserve).

At the end of the reporting period, the Group revises its estimates of the number of options that are expected to ultimately vest. The impact of the revision of the original estimates during the vesting period, if any, is recognised in profit or loss such that the cumulative expense reflects the revised estimate, with a corresponding adjustment to share options reserve.

When share options are exercised, the amount previously recognised in share options reserve will be transferred to share premium. When the share options are forfeited after the vesting date or are still not exercised at the expiry date, the amount previously recognised in share options reserve will continue to be held in share options reserve.



#### 4. Key Sources of Estimation Uncertainty

In the application of applying the Group's accounting policies, which are described in note 3, the management has made various estimates about the carrying amounts of assets and liabilities that are not readily apparent from other sources. The estimates are based on past experience, expectations of the future and other information that are considered to be relevant. Actual results may differ from these estimates.

The estimates and underlying assumptions are reviewed on an ongoing basis. Revisions to accounting estimates are recognised in the period in which the estimate is revised if the revision affects only that period, or in the period of the revision and future periods if the revision affects both current and future periods.

The following are the key assumptions concerning the future, and other key sources of estimation uncertainty at the end of reporting period, that have a significant risk of causing a material adjustment to the carrying amounts of assets and liabilities within the next financial year.

##### **Determination of net realisable value of properties under development for sale and completed properties for sale**

Properties under development for sale and completed properties for sale are stated at the lower of cost and net realisable value with aggregate carrying amount of approximately RMB10,222,320,000 (2010: RMB7,644,582,000). Cost of each unit in each phase of development is determined using the weighted average method. The net realisable value is the estimated selling price less estimated selling expenses and estimated cost of completion (if any), which are determined based on best available information. Where there is any decrease in the estimated selling price arising from any changes to the property market conditions in the PRC, there may be write-down on the properties under development for sale and completed properties for sale.

##### **LAT**

The Group is subject to land appreciation tax in the PRC. However, the implementation and settlement of the tax varies amongst different tax jurisdictions in various cities of the PRC and certain projects of the Group have not finalised their land appreciation tax calculations and payments with any local tax authorities in the PRC. Accordingly, significant estimate is required in determining the amount of land appreciation and its related income tax provisions. The Group recognised the land appreciation tax based on management's best estimates. The final tax outcome could be different from the amounts that were initially recorded, and these differences will impact the income tax expense and the related income tax provisions in the periods in which such tax is finalised with local tax authorities.

##### **Deferred tax assets**

Deferred tax assets are recognised for all unused tax losses to the extent that it is probable that taxable profit or taxable temporary difference will be available against which the losses can be utilised. Significant management estimation is required to determine the amount of deferred tax assets that can be recognised, based upon the likely timing and level of future taxable profits or taxable temporary difference together with future tax planning strategies.

##### **Recognition and allocation of construction costs on properties under development**

Development costs of properties are recorded as properties under development during the construction stage and will be transferred to completed properties for sale and charged to the consolidated statement of comprehensive income upon the recognition of the sales of the properties. Before the final settlement of the development costs and other costs relating to the sale of the properties, these costs are accrued by the Group based on management's best estimate. During the development stage, the Group typically divides the development projects into phases. Costs that are common to different phases are allocated to individual phases based on saleable area. Where the final settlement of costs and the related cost allocation is different from the initial estimates, any increase or decrease in the development costs and other costs would affect the profit or loss in future years.

## NOTES TO THE CONSOLIDATED FINANCIAL STATEMENTS

For the year ended 31 December 2011

### 5. Capital Risk Management

The Group manages its capital to ensure that entities in the Group will be able to continue as a going concern while maximising the return to shareholders through the optimisation of the debt and equity balance. The Group's overall strategy remains unchanged from prior year. The capital structure of the Group consists of debt, which includes amounts due to related parties as disclosed in note 34, borrowings as disclosed in note 35, senior notes as disclosed in note 36, cash and cash equivalents as disclosed in note 32 and equity attributable to owners of the Company, comprising share capital and reserves.

The directors of the Company review the capital structure periodically. As a part of this review, the corporate finance department reviews the planned construction projects proposed by engineering department and prepares the annual budget taking into account of the provision of funding.

The directors of the Company then assess the annual budget and consider the cost of capital and the risks associated with each class of capital. The directors of the Company also balance its overall capital structure through the payment of dividends, new share issues as well as the issue of new debt or the redemption of existing debt.

## NOTES TO THE CONSOLIDATED FINANCIAL STATEMENTS

For the year ended 31 December 2011

### 6. Financial Instruments

#### (a) Categories of financial instruments

	2011 RMB'000	2010 RMB'000
<b>Financial assets</b>		
Loans and receivables (including cash and cash equivalents)	2,530,510	3,535,453
<b>Financial liabilities</b>		
Amortised cost	7,655,232	7,306,656

#### (b) Financial risk management objectives and policies

The Group's major financial instruments include advance to an associate, deposits paid for acquisition of land use rights, subsidiaries and a property project, trade and other receivables, restricted bank deposits, bank balances and cash, trade and other payables, amounts due to related parties, borrowings and senior notes. Details of these financial instruments are disclosed in respective notes.

The management monitors and manages the financial risks relating to the operations of the Group through internal risk assessment which analyses exposures by degree and magnitude of risks. The risks included market risk (including currency risk and interest rate risk), credit risk and liquidity risk. The policies on how to mitigate these risks are set out below. The management manages and monitors these exposures to ensure appropriate measures are implemented on a timely and effective manner.

#### (c) Foreign currency risk management

The Group has bank balances, borrowings and senior notes which are denominated in foreign currencies of the relevant group entities, hence expose to exchange rate fluctuations.

The carrying amount of the Group's foreign currency denominated monetary assets and monetary liabilities at the respective reporting periods are as follow:

	2011 RMB'000	2010 RMB'000
<b>Assets</b>		
United States Dollars ("USD")	5,195	17,376
Hong Kong Dollars ("HKD")	288,798	520,692
Taiwan Dollars ("TWD")	3,496	–
<b>Liabilities</b>		
USD	1,596,688	1,449,600
HKD	163,761	199,111

The Group currently does not enter into any derivative contracts to minimise the currency risk exposure. However, the management will consider hedging significant currency risk should the need arises.

The Group mainly exposes to the effects of fluctuation in USD and HKD against RMB.

## NOTES TO THE CONSOLIDATED FINANCIAL STATEMENTS

For the year ended 31 December 2011

### 6. Financial Instruments (continued)

#### (c) Foreign currency risk management (continued)

The following table details the Group's sensitivity to a 5% (2010: 5%) increase and decrease in the RMB against the relevant foreign currencies. 5% (2010: 5%) is the sensitivity rate used in management's assessment of the reasonably possible change in foreign exchange rates. The sensitivity analysis includes only outstanding foreign currency denominated monetary items and adjusts their translation at the year end for a 5% (2010: 5%) change in foreign currency rates. The sensitivity analysis includes bank balances, borrowings and senior notes. A positive number indicates an increase in profit for the year where the RMB strengthens against the relevant currencies. For a 5% (2010: 5%) weakening of the RMB against the relevant currencies, there would be an equal and opposite impact on the profit for the year.

	2011 RMB'000	2010 RMB'000
<b>USD</b>		
Increase in profit for the year	79,575	71,613
<b>HKD</b>		
Decrease in profit for the year	(6,252)	(16,078)
<b>TWD</b>		
Decrease in profit for the year	(175)	–

During the year ended 31 December 2011, in management's opinion, the sensitivity analysis is unrepresentative of the foreign exchange risk as the year end exposure does not reflect the exposure during the year. USD denominated borrowings and HKD denominated bank balances were incurred in the last quarter of the 2010 financial year, which results in an increment in the respective balances at year end.

#### (d) Interest rate risk management

The Group is exposed to cash flow interest rate risk due to the fluctuation of the prevailing market interest rate on bank balances and variable-rate borrowings.

The Group is also exposed to fair value interest rate risk which relates primarily to its balance with a related party, fixed-rate borrowings and senior notes (see notes 34, 35 and 36). The Group currently does not use any derivative contracts to hedge its loans to interest rate risk. However, the management will consider hedging significant interest rate exposure should the need arises.

The Group's exposures to interest rates on financial liabilities are detailed in the liquidity risk management section of this note. The Group's cash flow interest rate risk is mainly concentrated on the fluctuation of the London Interbank Offered Rate ("LIBOR") arising from the Group's USD borrowings, the Hong Kong Interbank Offer Rate ("HIBOR") arising from the Group's HKD borrowings and Benchmark Borrowing Rate of The People's Bank of China ("Benchmark Rate") from the Group's RMB borrowings.

#### *Sensitivity analysis*

##### *Bank balances*

The sensitivity analysis below has been determined based on the exposure to interest rates for the bank balances at the end of the reporting period. A 25 basis points (2010: 25 basis points) increase or decrease is used and represents management's assessment of the reasonably possible change in interest rates.

If interest rates had been higher/lower by 25 basis points (2010: 25 basis points) and all other variables were held constant, the Group's profit for the year ended 31 December 2011 would increase/decrease by approximately RMB2,506,000 (2010: increase/decrease of approximately RMB4,607,000).

## 6. Financial Instruments (continued)

### (d) Interest rate risk management (continued)

#### *Sensitivity analysis* (continued)

##### *Variable-rate borrowings*

The sensitivity analysis below has been determined based on the exposure to interest rates for the variable-rate borrowings at the end of the reporting period. A 50 basis points (2010: 50 basis points) increase or decrease is used and represents management's assessment of the reasonably possible change in interest rates.

If interest rates had been higher/lower by 50 basis points (2010: 50 basis points) and all other variables were held constant, the Group's profit for the year ended 31 December 2011 would decrease/increase by approximately RMB5,036,000 (2010: decrease/increase of approximately RMB16,706,000), net of interest capitalised in accordance with the Group's accounting policy.

### (e) Credit risk management

As at 31 December 2011, the Group's maximum exposure to credit risk which will cause a financial loss to the Group due to failure to discharge an obligation by the counterparties and financial guarantees provided by the Group is arising from:

- the carrying amount of the respective recognised financial assets as stated in the consolidated statement of financial position; and
- the amount of contingent liabilities in relation to financial guarantee issued by the Group as disclosed in note 44.

In order to minimise the credit risk, the Group has policies in place for determination of credit limits, credit approvals and other monitoring procedures to ensure that follow-up action is taken to recover overdue debts. In addition, the Group reviews the recoverable amount of each individual trade debt at the end of the reporting period to ensure that adequate impairment losses are made for irrecoverable amounts. In this regard, the directors of the Company consider that the Group's credit risk is significantly reduced.

The Group has no significant concentration of credit risk on trade receivables, with exposure spread over a number of counterparties and customers.

At 31 December 2011, the Group has concentration of credit risk on the deposits paid for acquisition of a property project, which are all engaged in PRC property development business.

The Group's credit risk on liquid funds is limited because the counterparties are banks with high credit ratings and good reputation established in the PRC and Hong Kong. The Group's credit risk on deposits paid on acquisition of land use rights is not significant as the counterparties are enterprises with good reputation established in PRC.

For properties under development which are subject to pre-sales agreements, the Group typically provides guarantees to banks in connection with the customers' borrowing of mortgage loans to finance their purchase of the properties for an amount up to 70% of the total purchase price of the property. If a purchaser defaults on the payment of its mortgage during the term of guarantee, the bank holding the mortgage may demand the Group to repay the outstanding amount of the loan and any accrued interest thereon. Under such circumstances, the Group is able to retain the customer's purchase deposit and sell the property to recover any amounts paid by the Group to the bank. In this regard, the directors of the Company consider that the Group's credit risk is significantly reduced.

## NOTES TO THE CONSOLIDATED FINANCIAL STATEMENTS

For the year ended 31 December 2011

### 6. Financial Instruments (continued)

#### (f) Liquidity risk management

In the management of the liquidity risk, the Group monitors and maintains a level of cash and cash equivalents deemed adequate by the management to finance the Group's operations and mitigate the effects of fluctuations in cash flows. The management monitors the utilisation of borrowings and ensures compliance with loan covenants.

The Group relies on borrowings, amounts due to related parties and senior notes as a significant source of liquidity. As at 31 December 2011, the Group has total available unutilised overdraft and bank loan facilities of approximately RMB478,000,000 (2010: RMB869,145,000).

The following table details the Group's remaining contractual maturity for its non-derivative financial liabilities. The table has been drawn up based on the undiscounted cash flows of financial liabilities based on the earliest date on which the Group can be required to pay. Specifically, bank loans with a repayment on demand clause are included in the earliest time band regardless of the probability of the banks choosing to exercise their rights. The maturity dates for other non-derivative financial liabilities are based on the agreed repayment dates.

The table includes both interest and principal cash flows. To the extent that interest flows are floating rate, the undiscounted amount is derived from interest rate at the end of the reporting period.

#### Liquidity table

	Weighted average effective interest rate %	On demand or less than 1 month RMB'000	1-3 months RMB'000	3 months to 1 year RMB'000	1-5 years RMB'000	Over 5 years RMB'000	Total undiscounted cash flows RMB'000	Carrying amount RMB'000
<b>As at 31 December 2011</b>								
<b>Non-derivative financial liabilities</b>								
Trade and other payables	–	786,674	389,199	949,438	34,005	–	2,159,316	2,159,316
Amounts due to related parties	–	2,547	–	–	–	–	2,547	2,547
Borrowings								
– fixed rate	–	–	–	–	–	–	–	–
– variable rate	6.68	238,280	46,333	1,862,997	2,544,013	799,036	5,490,659	4,741,002
Financial guarantee contracts	–	2,478,814	–	–	–	–	2,478,814	–
Senior notes	14.89	–	–	105,855	1,020,746	–	1,126,601	752,367
		3,506,315	435,532	2,918,290	3,598,764	799,036	11,257,937	7,655,232
<b>As at 31 December 2010</b>								
<b>Non-derivative financial liabilities</b>								
Trade and other payables	–	471,003	680,213	481,389	11,186	–	1,643,791	1,643,791
Amount due to a related party	7.02	100,549	–	–	–	–	100,549	100,549
Borrowings								
– fixed rate	5.37	1,432	2,865	111,167	225,709	–	341,173	320,000
– variable rate	5.58	224,813	144,329	1,645,777	2,695,855	109,072	4,819,846	4,454,986
Financial guarantee contracts	–	1,689,775	–	–	–	–	1,689,775	–
Senior notes	14.89	–	–	111,261	1,184,139	–	1,295,400	787,330
		2,487,572	827,407	2,349,594	4,116,889	109,072	9,890,534	7,306,656

## 6. Financial Instruments (continued)

### (f) Liquidity risk management (continued)

Bank loans with a repayment on demand clause are included in the “on demand or less than 1 month” time band in the above maturity analysis. As at 31 December 2011, the aggregate undiscounted principal amounts of these bank loans amounted to approximately RMB203,761,000 (2010: RMB199,111,000). Taking into account the Group’s financial position, the directors do not believe that it is probable that the banks will exercise their discretionary rights to demand immediate repayment. The directors believe that such bank loans will be repaid ranging from 1 year to 3 years after the reporting date in accordance with the scheduled repayment dates set out in the loan agreements. At that time, the aggregate principal and interest cash outflows will amount to RMB221,662,000 (2010:RMB215,977,000).

The amounts included above for financial guarantee contracts are the maximum amounts the Group could be required to settle under the arrangement for the full guaranteed amount if that amount is claimed by the counterparty to the guarantee. Based on expectations at the end of the reporting period, the Group considers that it is more likely than not that no amount will be payable under the arrangement. However, this estimate is subject to change depending on the probability of the counterparty claiming under the guarantee which is a function of the likelihood that the financial receivables held by the counterparty which are guaranteed suffer credit losses.

The amounts included above for variable interest rate instruments for non-derivative financial liabilities is subject to change if changes in variable interest rates differ to those estimates of interest rates determined at the end of the reporting period.

### (g) Fair value

The fair values of financial assets and financial liabilities are determined as follow:

- the fair values of financial assets and financial liabilities with standard terms and conditions and traded in active liquid markets are determined with reference to quoted market bid prices and ask prices respectively; and
- the fair values of other financial assets and financial liabilities are determined is determined in accordance with generally accepted pricing models based on discounted cash flow analysis.

Except for the senior notes set out in note 36, the directors consider that the carrying amounts of financial assets and financial liabilities recorded at amortised costs in the consolidated financial statements approximate their fair values.

## NOTES TO THE CONSOLIDATED FINANCIAL STATEMENTS

For the year ended 31 December 2011

### 7. Revenue and Segment Information

	2011 RMB'000	2010 RMB'000
Sales of properties (Note)	5,396,289	4,320,413
Rental income from investment properties	37,887	17,727
Agency fee from provision of property agency services	10,571	36,845
Management fee and installation services fee from provision of property operation services	124,895	89,228
Hotel operations	22,708	7,021
	5,592,350	4,471,234

Note: The properties sold by the Group are mainly represented by residential properties.

The segment information reported externally was analysed on the basis of their products and services supplied by the Group's operating divisions which is consistent with the internal information that are regularly reviewed by the directors of the Company, the chief operating decision maker, for the purposes of resource allocation and assessment of performance. This is also the basis of organisation in the Group, whereby the management has chosen to organise the Group around differences in products and services.

Inter-segment revenue are eliminated on consolidation.

The Group has five reportable and operating segments as follows:

Property development	–	developing and selling of properties in the PRC
Property investment	–	leasing of investment properties
Property agency services	–	provision of property agency and other related services
Property operation services	–	provision of property management, installation of security systems and other related services
Hotel operations	–	provision of hotel accommodation, hotel management and related services, food and beverage sales and other ancillary services

The accounting policies of the operating segments are the same as the Group's accounting policies described in note 3. Segment profit represents the profit earned by each segment without allocation of central administration costs and directors' salaries, interest income, imputed interest income on non-current interest-free advance to an associate, exchange gain, share of results of associates, gain on disposal of an associate, finance costs and income tax expense. This is the measure reported to the chief operating decision maker for the purposes of resources allocation and assessment of segment performance.

For the purposes of monitoring segment performance and allocating resources between segments, the chief operating decision maker also reviews the segment assets attributable to each operating segment, which comprises assets other than interests in associates, advance to an associate, restricted bank deposits, bank balances and cash and other corporate assets.



## 7. Revenue and Segment Information (continued)

The following is an analysis of the Group's revenue, results and other material items by reportable and operating segment under review:

### Segment revenues, results, assets and other material items for 31 December 2011:

	Property development RMB'000	Property investment RMB'000	Property agency services RMB'000	Property operation services RMB'000	Hotel operations RMB'000	Total RMB'000
External revenues	5,396,289	37,887	10,571	124,895	22,708	5,592,350
Inter-segment revenues	3,617	1,835	7,430	158,781	–	171,663
Segment result	1,839,573	400,483	42,396	68,366	(39,869)	2,310,949
Segment assets	13,319,848	2,445,142	2,011	302,290	422,111	16,491,402

Amounts included in the measure  
of segment profit or loss or  
segment assets:

Additions to non-current assets (note)	51,822	524,753	144	8,185	153,284	738,188
Change in fair value of investment properties	–	182,980	–	–	–	182,980
Recognition of change in fair value of completed properties for sale upon transfer to investment properties	–	191,142	–	–	–	191,142
Release of prepaid lease payments	4,736	–	–	–	88	4,824
Release of premium on prepaid lease payments	6,864	–	–	–	–	6,864
Depreciation of property, plant and equipment	7,771	–	338	2,450	10,687	21,246
Loss (gain) on disposal of property, plant and equipment	33	–	–	(25)	(13)	(5)
(Reversal) allowance on bad and doubtful debts, net	(2,334)	–	–	2,069	–	(265)

Inter-segment revenues are charged at prevailing market rate.

## NOTES TO THE CONSOLIDATED FINANCIAL STATEMENTS

For the year ended 31 December 2011

### 7. Revenue and Segment Information (continued)

Segment revenues, results, assets and other material items for 31 December 2010:

	Property development RMB'000	Property investment RMB'000	Property agency services RMB'000	Property operation services RMB'000	Hotel operations RMB'000	Total RMB'000
External revenues	4,320,413	17,727	36,845	89,228	7,021	4,471,234
Inter-segment revenues	5,184	–	32,511	18,557	5	56,257
Segment result	1,606,296	403,384	7,409	36,244	(14,836)	2,038,497
Segment assets	10,522,812	1,703,856	10,959	105,042	329,400	12,672,069

Amounts included in the measure  
of segment profit or loss or  
segment assets:

Additions to non-current assets (note)	39,390	795,848	872	6,332	175,693	1,018,135
Change in fair value of investment properties	–	320,461	–	–	–	320,461
Recognition of change in fair value of completed properties for sale upon transfer to investment properties	–	67,326	–	–	–	67,326
Release of prepaid lease payments	8,039	–	–	–	–	8,039
Release of premium on prepaid lease payments	3,997	–	–	–	–	3,997
Depreciation of property, plant and equipment	5,287	–	1,582	1,777	2,294	10,940
Gain on disposal of property, plant and equipment	(11)	–	(66)	–	–	(77)
Allowance on bad and doubtful debts, net	2,400	–	–	537	–	2,937

Inter-segment revenues are charged at prevailing market rate.

Note: Additions to non-current assets comprise mainly additions to property plant and equipment and investment properties and exclude interests in associates, advance to an associate, prepayment, deposits paid for acquisition of subsidiaries and a property project, deferred tax assets.

## 7. Revenue and Segment Information (continued)

### Reconciliation:

	2011 RMB'000	2010 RMB'000
<b>Revenue:</b>		
Total revenue for reportable segments	5,764,013	4,527,491
Elimination of inter-segment revenues	(171,663)	(56,257)
Group's total revenues	5,592,350	4,471,234
<b>Profit or loss:</b>		
Segment result	2,310,949	2,038,497
Elimination of inter-segment result	(50,728)	(43,134)
Unallocated amounts:		
Unallocated income	38,053	20,917
Unallocated corporate expenses	(40,346)	(41,502)
Finance costs	(108,471)	(180,131)
Impairment of loss recognised in respect of goodwill	(1,321)	(5,375)
Share of results of associates	171	406
Gain on disposal of an associate	3,533	–
Profit before taxation	2,151,840	1,789,678
<b>Assets:</b>		
Total assets for reportable segments	16,491,402	12,672,069
Unallocated assets:		
Interests in associates	1,077	17,795
Advance to an associate	–	72,041
Restricted bank deposits	62,198	85,161
Bank balances and cash	1,274,291	2,371,452
Corporate assets	293,668	163,870
Group's total assets	18,122,636	15,382,388

## NOTES TO THE CONSOLIDATED FINANCIAL STATEMENTS

For the year ended 31 December 2011

### 7. Revenue and Segment Information (continued)

#### Reconciliation: (continued)

	2011 RMB'000	2010 RMB'000
<b>Other material items:</b>		
<i>Release of prepaid lease payments</i>		
Reportable segment totals	4,824	8,039
Unallocated amount	–	–
Group's total	4,824	8,039
<i>Release of premium on prepaid lease payments</i>		
Reportable segment totals	6,864	3,997
Unallocated amount	–	–
Group's total	6,864	3,997
<i>Depreciation of property, plant and equipment</i>		
Reportable segment totals	21,246	10,940
Unallocated amount	228	118
Group's total	21,474	11,058
<i>Additions to non-current assets</i>		
Reportable segment totals	738,188	1,018,135
Unallocated amount	568	69
Group's total	738,756	1,018,204
<i>Gain on disposal of property, plant and equipment</i>		
Reportable segment totals	(5)	(77)
Unallocated amount	–	–
Group's total	(5)	(77)
<i>(Reversal) allowance on bad and doubtful debt, net</i>		
Reportable segment totals	(265)	2,937
Unallocated amount	–	–
Group's total	(265)	2,937
<i>Impairment loss recognised in respect of goodwill</i>		
Reportable segment totals	1,321	5,375
Unallocated amount	–	–
	1,321	5,375

The Group's revenue from external customers is derived solely from its operations in the PRC, and non-current assets of the Group are mainly located in the PRC.

During the years ended 31 December 2011 and 2010, there was no revenue from transactions with a single external customer amounted to 10% or more of the Group's total revenue.

## 8. Other Income, Gains and Losses

	2011 RMB'000	2010 RMB'000
Interest income	8,941	15,781
Imputed interest income on non-current interest-free advance to an associate	537	3,593
Forfeiture income on deposits received	1,148	378
Government grant (note)	5,797	10,133
Net exchange gain	28,573	1,618
Others	1,926	696
	46,922	32,199

Note: The amount represents the grants received from the relevant PRC government to encourage the development of real estate industry. The subsidies are unconditional and granted on a discretionary basis to the Group during the year.

## 9. Finance Costs

	2011 RMB'000	2010 RMB'000
Interest on:		
– borrowings wholly repayable within five years	294,931	239,575
– borrowings not wholly repayable within five years	30,247	1,742
– senior notes	75,029	74,589
– amounts due to related parties	1,744	7,098
Less: Amount capitalised in properties under development for sale	(256,522)	(139,657)
Amount capitalised in land development expenditure	(32,039)	–
Amount capitalised in investment properties under development	(4,663)	–
Amount capitalised in construction in progress	(256)	(3,216)
	108,471	180,131

In 2010, certain amount of borrowing costs capitalised arose on the general borrowing pool and were calculated by applying the capitalisation rates of 6.06% per annum to expenditure on qualifying assets. In 2011, all the borrowing cost capitalised arose on the specific borrowings.

## NOTES TO THE CONSOLIDATED FINANCIAL STATEMENTS

For the year ended 31 December 2011

### 10. Profit before Taxation

	2011 RMB'000	2010 RMB'000
Profit before taxation has been arrived at after charging (crediting):		
Directors' emoluments (note 12)	8,617	10,104
Other staff's salaries and allowances	218,619	181,983
Retirement benefit scheme contributions	22,052	13,575
Share-based payment	1,578	–
Total staff costs	250,866	205,662
Less: Amount capitalised in properties under development for sale	(67,475)	(36,690)
	183,391	168,972
Auditor's remuneration	4,069	3,221
Release of prepaid lease payments	4,824	8,039
Release of premium on prepaid lease payments	6,864	3,997
Depreciation of property, plant and equipment	21,474	11,058
Gain on disposal of property, plant and equipment	(5)	(77)
(Reversal) allowance on bad and doubtful debts, net	(265)	2,937
Cost of properties recognised as an expense	2,771,307	2,014,859
Contract cost recognised as an expense	39,318	27,456
Rental expenses in respect of rented premises under operating leases	7,688	8,636
Gross rental income from investment properties	(37,887)	(17,727)
Less: direct operating expenses from investment properties that generated rental income	3,658	2,130
	(34,229)	(15,597)

### 11. Income Tax Expense

	2011 RMB'000	2010 RMB'000
Current tax:		
PRC taxes		
EIT	520,569	360,752
LAT	403,675	440,801
	924,244	801,553
Deferred tax (note 27)		
Current year	18,768	34,800
Underprovision of deferred tax assets	(813)	(7,645)
	17,955	27,155
	942,199	828,708

## 11. Income Tax Expense (continued)

No provision for Hong Kong Profits Tax has been made in the consolidated financial statements as the income of the Group neither arise in nor is derived from Hong Kong.

The Group's PRC enterprise income tax is calculated based on the applicable tax rate on assessable profits, if applicable.

PRC land appreciation tax is levied at progressive rates ranging from 30% to 60% on the appreciation of land value, being the proceeds of sales of properties less deductible expenditures including cost of land use rights and all property development expenditures.

The income tax expense for the year can be reconciled to the profit before taxation per the consolidated statement of comprehensive income as follows:

	2011 RMB'000	2010 RMB'000
Profit before taxation	2,151,840	1,789,678
Tax at PRC enterprise income tax rate of 25% (2010: 25%) (note i)	537,960	447,420
Tax effect of share of results of associates	(43)	(102)
Tax effect of income not taxable for tax purposes	(1,131)	(898)
Tax effect of expenses not deductible for tax purposes (note ii)	58,271	33,525
Tax effect of tax losses not recognised	60,575	40,418
Utilisation of tax losses previously not recognised	(5,858)	(3,076)
Tax effect of different tax rates of subsidiaries	(9,518)	(11,535)
LAT	403,675	440,801
Tax effect of LAT	(100,919)	(110,200)
Underprovision of deferred tax assets	(813)	(7,645)
Income tax expense for the year	942,199	828,708

Notes:

- (i) Majority of the assessable profits of the Group were derived from subsidiaries situated in Shenzhen and Chengdu of the PRC and the applicable enterprise income tax rate of those subsidiaries were 25%.
- (ii) The amounts for the years ended 31 December 2011 and 2010 mainly relate to the tax effect of expenses incurred by offshore companies, including the interest on senior notes and professional fees.

## NOTES TO THE CONSOLIDATED FINANCIAL STATEMENTS

For the year ended 31 December 2011

### 12. Directors' and Employees' Remuneration

The emoluments of the directors on a named basis are as follows:

	Fees RMB'000	Salaries and other benefits RMB'000	Discretionary bonus RMB'000 (note)	Retirement benefit scheme contributions RMB'000	Share-based payment RMB'000	Total RMB'000
<b>For the year ended 31 December 2011</b>						
<i>Executive director:</i>						
Pan Jun (潘軍)	–	1,802	–	37	150	1,989
Zeng Jie (曾寶寶)	–	1,802	–	37	150	1,989
Feng Huiming (馮輝明)	–	1,003	656	37	151	1,847
Chan Sze Hon (陳思翰)	–	1,010	602	9	115	1,736
<i>Independent non-executive director:</i>						
He Min (何敏)	240	–	–	–	24	264
Huang Ming (黃明)	240	–	–	–	24	264
Liao Changjiang (廖長江)	240	–	–	–	24	264
Xu Quan (許權)	240	–	–	–	24	264
	960	5,617	1,258	120	662	8,617
<b>For the year ended 31 December 2010</b>						
<i>Executive director:</i>						
Pan Jun (潘軍)	–	1,776	1,398	22	–	3,196
Zeng Jie (曾寶寶)	–	1,776	458	21	–	2,255
Feng Huiming (馮輝明)	–	1,003	1,193	22	–	2,218
Chan Sze Hon (陳思翰)	–	1,045	420	10	–	1,475
<i>Independent non-executive director:</i>						
He Min (何敏)	240	–	–	–	–	240
Huang Ming (黃明)	240	–	–	–	–	240
Liao Changjiang (廖長江)	240	–	–	–	–	240
Xu Quan (許權)	240	–	–	–	–	240
	960	5,600	3,469	75	–	10,104

Note: The discretionary bonus is determined by the board of directors based on the Group's performance for each financial year.



## 12. Directors' and Employees' Remuneration (continued)

### Employees' emoluments

The five individuals with the highest emoluments in the Group included 2 directors (2010: 3) for both years. Details of their emoluments are set out above. The emoluments of the remaining 3 (2010: 2) of the five highest paid individuals are as follows:

	2011 RMB'000	2010 RMB'000
Salaries and allowances	2,198	1,515
Discretionary bonus	4,003	3,339
Retirement benefit scheme contributions	109	50
Share-based payment	185	–
	6,495	4,904

Their emoluments were within the following band:

	2011 No. of employees	2010 No. of employees
HK\$2,000,001 to HK\$3,000,000	2	1
HK\$3,000,001 to HK\$3,500,000	1	1

During the years ended 31 December 2011 and 2010, no remuneration was paid by the Group to any of the directors or the five highest paid individuals as an inducement to join or upon joining the Group or as compensation for loss of office. None of the directors waived any remuneration for the years ended 31 December 2011 and 2010.

## NOTES TO THE CONSOLIDATED FINANCIAL STATEMENTS

For the year ended 31 December 2011

### 13. Dividends

	2011 RMB'000	2010 RMB'000
Final dividend for 2010 of HK4.00 cents per share (2009: HK1.75 cents) (Note i)	165,888	75,100
Dividends paid to non-controlling shareholders (Note ii)	8,722	3,297

Notes:

- (i) Subsequent to the end of the reporting period, a final dividend for 2011 of HK4.00 cents (2010: final dividend for 2010 of HK\$4.00 cents) per share amounting to HK\$208,289,000 in aggregate has been proposed by the directors for approval by the shareholders in the annual general meeting. The final dividends proposed after the end of the reporting period has not been recognised as a liability at the end of the reporting period.
- (ii) The amount represents dividends paid by the PRC subsidiaries to their non-controlling shareholders.

### 14. Earnings Per Share

The calculation of the basic earnings per share attributable to the owners of the Company is based on the following data:

	2011 RMB'000	2010 RMB'000
<b>Earnings</b>		
Earnings for the purpose of basic earnings per share (Profit for the year attributable to owners of the Company)	1,153,624	807,281
	2011	2010
<b>Number of Shares</b>		
Weighted average number of ordinary shares for the purpose of basic earnings per share	5,041,481,175	4,873,888,750

The weighted average number of ordinary shares during the year ended 31 December 2011 has been adjusted for the effect of the subscription shares as set out in note 37.

The computation of diluted earnings per share does not assume the exercise of the Company's options (note 42) because the exercise price of those options was higher than the average market price for shares from grant date on 29 August 2011 to the end of year 2011.

## 15. Property, Plant and Equipment

	Hotel buildings RMB'000	Buildings RMB'000	Renovations and leasehold improvements RMB'000	Furniture, fixtures and equipment RMB'000	Motor vehicles RMB'000	Construction in progress RMB'000	Total RMB'000
<b>COST</b>							
At 1 January 2010	–	24,246	21,151	24,599	10,749	118,305	199,050
Transfer from completed properties for sale (Note i)	–	5,348	–	–	–	–	5,348
Transfer from properties under development for sale (Note ii)	–	–	–	–	–	137,277	137,277
Acquisition of assets and liabilities through acquisition of subsidiaries (note 38(a))	–	–	–	228	134	–	362
Acquisition of business (note 38(b))	–	872	–	3	–	–	875
Additions	–	–	4,213	9,954	8,529	55,798	78,494
Transfer	54,489	9,309	198	4,132	–	(68,128)	–
Disposals	–	–	–	(792)	(346)	–	(1,138)
At 31 December 2010 and 1 January 2011	54,489	39,775	25,562	38,124	19,066	243,252	420,268
Transfer from completed properties for sale (Note i)	44,906	–	–	–	–	–	44,906
Transfer from properties under development for sale (Note ii)	–	–	–	–	–	11,270	11,270
Acquisition of business (note 38(b))	–	–	–	18	–	–	18
Additions	–	4,312	657	23,474	4,561	124,805	157,809
Transfer	–	40,933	–	93	–	(41,026)	–
Transfer to investment properties (Note iii)	–	(27,939)	–	–	–	–	(27,939)
Disposals	–	(8,387)	(761)	(1,456)	(882)	–	(11,486)
Disposal of a subsidiary (note 39)	–	–	(5,115)	(3,480)	(802)	–	(9,397)
At 31 December 2011	99,395	48,694	20,343	56,773	21,943	338,301	585,449
<b>DEPRECIATION</b>							
At 1 January 2010	–	4,799	11,738	12,186	6,797	–	35,520
Provided for the year	895	1,370	2,310	4,345	2,138	–	11,058
Eliminated on disposals	–	–	–	(408)	(336)	–	(744)
At 31 December 2010 and 1 January 2011	895	6,169	14,048	16,123	8,599	–	45,834
Provided for the year	4,779	1,879	2,219	9,708	2,889	–	21,474
Eliminated on disposals	–	(859)	(760)	(911)	(847)	–	(3,377)
Eliminated on disposal of a subsidiary (note 39)	–	–	(4,907)	(2,472)	(318)	–	(7,697)
At 31 December 2011	5,674	7,189	10,600	22,448	10,323	–	56,234
<b>CARRYING AMOUNTS</b>							
At 31 December 2011	93,721	41,505	9,743	34,325	11,620	338,301	529,215
At 31 December 2010	53,594	33,606	11,514	22,001	10,467	243,252	374,434

## NOTES TO THE CONSOLIDATED FINANCIAL STATEMENTS

For the year ended 31 December 2011

### 15. Property, Plant and Equipment (Continued)

Notes:

- (i) During the year ended 31 December 2011, buildings of RMB44,906,000 (2010: RMB5,348,000) were transferred from completed properties for sale as a result of the change in use of property as approved by the management of the Group.
- (ii) During the year ended 31 December 2011, RMB11,270,000 (2010: RMB137,277,000) was transferred from properties under development for sale as a result of change in intended use to self-use properties as approved by the management of the Group.
- (iii) During the year ended 31 December 2011, RMB27,939,000 was transferred from buildings to investment properties upon signing of relevant tenancy agreements. The excess of the fair value of these properties at the date of change in use over the carrying amounts, amounting to approximately RMB11,795,000 were recognised in the revaluation surplus.

The following useful lives are used in the calculation of depreciation:

Hotel buildings	Over the shorter of the term of lease or 20 years
Buildings	Over the shorter of the term of lease or 50 years
Renovations and leasehold improvements	5–10 years
Furniture, fixtures and equipment	5 years
Motor vehicles	5 to 10 years

At 31 December 2011, certain of the Group's buildings and construction in progress with carrying amounts of RMB1,121,000 (2010: RMB10,384,000) and nil (2010: RMB233,688,000) respectively, were pledged to banks to secure certain banking facilities granted to the Group.

The hotel buildings amounting to approximately RMB47,830,000 (2010: RMB53,594,000) and RMB45,891,000 (2010: Nil) are held under medium-term and long-term leases in the PRC, respectively. All the buildings are held under medium-term lease in the PRC at the end of both reporting periods.

### 16. Investment Properties

	Completed RMB'000	Under development RMB'000	Total RMB'000
<b>FAIR VALUE OR COST</b>			
At 1 January 2010	496,996	84,372	581,368
Transfer from deposits paid for acquisition of a property project	86,523	265,533	352,056
Acquisition of assets and liabilities through acquisition of subsidiaries (note 38(a))	6,717	–	6,717
Additions	–	330,519	330,519
Transfer from completed properties for sale (note 28)	106,556	–	106,556
Transfers upon completion of construction work	160,507	(160,507)	–
Net change in fair value recognised in profit or loss	(12,769)	333,230	320,461
At 31 December 2010 and 1 January 2011	844,530	853,147	1,697,677
Transfer from property, plant and equipment (note 15)	39,734	–	39,734
Additions	–	278,636	278,636
Transfer from completed properties for sale (note 28)	246,117	–	246,117
Transfers upon completion of construction work	993,338	(993,338)	–
Disposal	(1,450)	–	(1,450)
Net change in fair value recognised in profit or loss	71,602	111,378	182,980
At 31 December 2011	2,193,871	249,823	2,443,694

## 16. Investment Properties (Continued)

At 31 December 2011, the fair values of the Group's completed investment properties of approximately RMB2,193,871,000 (2010: RMB844,530,000) and investment properties under development of approximately nil (2010: RMB682,815,000) at the end of the reporting period were arrived at on the basis of a valuation carried out by Jones Lang LaSalle Sallmanns Limited. Jones Lang LaSalle Sallmanns Limited is a firm of independent qualified professional valuers not connected with the Group, and has appropriate qualifications and recent experiences in the valuation of similar properties in the relevant locations. The valuations of completed investment properties were arrived at by reference to net rental income allowing for reversionary income potential and market evidence of transaction prices for similar properties in the same locations and conditions, where appropriate. The valuations of investment properties under development has been arrived at using the capitalisation of net income derived from the properties located nearby, taking into account the construction costs that would be expended to complete the development, the developer's profit and percentage of completion of the properties.

At 31 December 2011, the Group has concluded the fair value of certain investment properties under development with carrying amounts of approximately RMB249,823,000 (2010: RMB170,332,000) are not reliably determinable on a continuing basis, therefore, these investment properties under development continued to be measured at cost until either its fair value becomes reliably determinable or construction is completed.

At 31 December 2011, investment properties with fair value of RMB484,365,000 (2010: RMB476,825,000) represents completed car parks which can be legally transferred, leased and mortgaged but the title certificates cannot be currently applied as there was no special provisions to obtain any title certificates, according to the relevant laws and regulations in Shenzhen, Suzhou and Tianjin areas.

At 31 December 2011, certain of the Group's investment properties with an aggregate fair value of approximately RMB1,015,147,000 (2010: RMB325,457,000) were pledged to banks to secure the banking facilities granted to the Group.

The investment properties amounting to approximately RMB920,737,000 (2010: RMB439,661,000) and RMB1,509,970,000 (2010: RMB1,258,016,000) are held under medium-term and long-term leases in the PRC, respectively.

All of the Group's property interests held under operating leases to earn rentals are measured using the fair value model and are classified and accounted for as investment properties.

## NOTES TO THE CONSOLIDATED FINANCIAL STATEMENTS

For the year ended 31 December 2011

### 17. Interests in Associates

	2011 RMB'000	2010 RMB'000
Cost of investment, unlisted	500	7,250
Share of post-acquisition results and other comprehensive income, net of dividends received	577	(6,344)
Deemed capital contributions	–	16,889
	1,077	17,795

Included in interests in associates as at 31 December 2010 were fair value adjustments of RMB16,889,000 on interest-free non-current advance to an associate. The details are set out in note 18.

During the year ended 31 December 2010, a discount on acquisition of RMB385,000, arising on the acquisition of Yuezhong Property Management Company Limited (越眾物業管理有限公司) had been included as income in the determination of the Group's share of results of associates.

As at 31 December 2011 and 2010, the Group had interests in the following associates:

Name of associate	Registered capital	Equity interest attributable to the Group as at 31 December		Principal activities
		2011	2010	
越眾物業管理有限公司 Yuezhong Property Management Company Limited	RMB1,000,000	50%	50%	Property management
東莞市左庭右院實業投資有限公司 Dongguan Zuoting Youyuan	RMB18,000,000	– (Note)	37.5%	Property development

Note: The associate was disposed of during the year ended 31 December 2011.

The summarised financial information in respect of the Group's associates is set out below:

	2011 RMB'000	2010 RMB'000
Total assets	5,796	299,311
Total liabilities	3,641	303,389
Net assets (liabilities)	2,155	(4,078)
Group's share of net assets of associates	1,077	906

## 17. Interests in Associates (continued)

	2011 RMB'000	2010 RMB'000
Revenue	9,622	2,443
Total comprehensive income (expense) for the year	347	(1,729)
Group's share of results of associates (note)	171	(258)

Note: During the year ended 31 December 2011, the unrecognised share of loss of associates was approximately RMB234,000 (2010: RMB279,000). In the opinion of directors, there are no significant unrecognised share of capital commitment and contingent liabilities at the end of the reporting period.

## 18. Advance to an Associate

	2011 RMB'000	2010 RMB'000
Dongguan Zuoting Youyuan	–	72,041

At 31 December 2010, the amount represented the advance to an associate which were non-trade nature and will not be recoverable within one year from the end of the reporting period and therefore considered as a non-current asset. The amount was unsecured, interest-free and measured at amortised cost using the effective interest method at the borrowing rate of 5.48% per annum.

The balance was disposed together with the equity interests held by Group at a cash consideration of RMB96,000,000 during 31 December 2011.

## 19. Prepaid Lease Payments

The Group's prepaid lease payments comprise:

	2011 RMB'000	2010 RMB'000
Leasehold land in the PRC		
Medium-term lease	68,312	64,700
Long-term lease	101,408	288,226
	169,720	352,926
Analysed for reporting purposes as:		
Current asset	6,413	6,881
Non-current asset	163,307	346,045
	169,720	352,926

## NOTES TO THE CONSOLIDATED FINANCIAL STATEMENTS

For the year ended 31 December 2011

### 19. Prepaid Lease Payments (continued)

During the year ended 31 December 2011, the Group acquired prepaid lease payments of approximately RMB19,547,000 (2010: RMB1,008,907,000) through the acquisition of subsidiaries as disclosed in note 38(a).

During the year ended 31 December 2011, the Group acquired prepaid lease payments of approximately RMB911,507,000 (2010: RMB700,696,000) through public auction, among which approximately RMB763,095,000 was paid during the year 31 December 2010 as deposits paid for acquisition of land use rights (note 22).

During the year ended 31 December 2011, prepaid lease payments of approximately RMB7,110,000 (2010: RMB2,957,000) were transferred from properties under development for sale as a result of change in intended use of the land to self-use properties. Amortisation charge of RMB1,620,000 (2010: RMB1,613,000) provided for the leasehold land is capitalised into construction in progress. The capitalisation of amortisation charge will cease when the assets are ready for their intended use.

During the year ended 31 December 2011, prepaid lease payments of RMB1,114,926,000 (2010: RMB1,519,143,000) was transferred to properties under development for sale upon commencement of the related construction work in certain property development projects.

At 31 December 2010, the Group was in the process of obtaining the land use right certificate for a prepaid lease payment with an aggregate carrying amount of approximately RMB120,675,000. The aforesaid land use right certificates have been obtained during the year ended 31 December 2011. As at 31 December 2011, all land use right certificates have been obtained.

At 31 December 2011, certain of the Group's prepaid lease payments with a carrying amount of approximately RMB62,310,000 (2010: RMB148,237,000) were pledged to banks to secure the banking facilities granted to the Group.



## 20. Premium on Prepaid Lease Payments

Premium on prepaid lease payments of the Group represent the excess of the fair value over the carrying amount of the prepaid lease payments in respect of leasehold lands in the PRC under medium-term and long-term lease acquired through purchase of subsidiaries during the year and are amortised over the period of the remaining lease term on a straight-line basis.

	RMB'000	
<b>COST</b>		
At 1 January 2010		47,579
Acquisition of assets and liabilities through acquisition of subsidiaries (note 38(a))		814,509
Transfer to properties under development for sale (Note)		(494,570)
At 31 December 2010 and 1 January 2011		367,518
Acquisition of assets and liabilities through acquisition of subsidiaries (note 38(a))		187,956
Transfer to properties under development for sale (Note)		(95,000)
At 31 December 2011		460,474
<b>AMORTISATION</b>		
At 1 January 2010		357
Amortised for the year		3,997
Eliminated on transfer to properties under development for sale (Note)		(2,140)
At 31 December 2010 and 1 January 2011		2,214
Amortised for the year		6,864
Eliminated on transfer to properties under development for sale (Note)		(36)
At 31 December 2011		9,042
<b>CARRYING AMOUNTS</b>		
At 31 December 2011		451,432
At 31 December 2010		365,304
	2011	2010
	RMB'000	RMB'000
Analysed for reporting purposes as:		
Current asset	11,157	6,101
Non-current asset	440,275	359,203
	451,432	365,304

Note: During the year ended 31 December 2011, premium on prepaid lease payments with carrying amount of approximately RMB94,964,000 (2010: RMB492,430,000) was transferred to properties under development for sales upon commencement of the related construction work in certain property development projects.

## NOTES TO THE CONSOLIDATED FINANCIAL STATEMENTS

For the year ended 31 December 2011

### 21. Land Development Expenditure

	2011 RMB'000	2010 RMB'000
Cost incurred	1,335,848	393,849

- (i) In September 2009, the Group entered into agreement (“Agreement 1”) with the People’s Government of Pixian County (“Pixian Government”) relating to the joint development of the Wangcong Ancient Sichuan Culture Park located in Pixian County, Chengdu, Sichuan Province (“Land Development Project 1”). Under the Agreement 1, the Group is responsible for preparing overall plans and detailed designs of the culture park including the improvement for parcels of land and its ancillary facilities pursuant to the guidelines set by the Pixian Government as well as the construction of road nearby while the Pixian Government is required to complete the demolition and resettlement work on these parcels of land. The land development expenditure represents the cost incurred in respect of the road construction, demolition and resettlement work. The additions during the year ended 31 December 2011 amounted to approximately RMB411,999,000 and the balance at 31 December 2011 is RMB805,848,000.

Pixian Government is required to arrange public auction for these parcels of land after 30 days that the Group completed the road construction, demolition and resettlement work and the Pixian Government is required to pay certain percentage of sale proceeds received in public auction to the Group by reference to the formula set out in the Agreement 1.

The Land Development Project 1 is not expected to be completed within the normal operating cycle of the Group and accordingly is classified as non-current assets.

- (ii) In March 2011, the Group entered into agreement (“Agreement 2”) with the People’s Government of Chengdu (“Chengdu Government”) relating to the joint development of the Wu Gui Qiao Town located in Jinjiang area, Chengdu, Sichuan Province (“Land Development Project 2”). Under the Agreement 2, the Group is required to jointly construct the ancillary facilities on these parcels of land pursuant to the guidelines set by the Chengdu Government while the Chengdu Government is required to complete the demolition and resettlement work on these parcels of land. The land development expenditure represents the cost incurred for constructing the ancillary facilities. The additions during the year ended 31 December 2011 amounted to approximately RMB530,000,000 and balance at 31 December 2011 is amounting to approximately RMB530,000,000.

Chengdu Government is required to arrange public auction for these parcels of land on or before 30 June 2013 after the Group has completed the construction of ancillary facilities and the Chengdu Government is required to pay certain percentage of sale proceeds received in public auction to the Group by reference to the formula set out in the Agreement 2.

The Land Development Project 2 is not expected to be completed within the normal operating cycle of the Group and accordingly is classified as non-current assets.

## **22. Deposits Paid for Acquisition of Land Use Rights**

As at 31 December 2010, the Group had made deposits of approximately RMB763,095,000 in relation to acquisition of land use rights from independent third parties (2011: Nil). The aforesaid deposits relate to land use rights acquired for development of properties for sale in the ordinary course of business and are therefore classified as current assets. The acquisition has been completed during the year ended 31 December 2011.

## **23. Deposits Paid for Acquisition of Subsidiaries**

During the year ended 31 December 2011, the Group has made deposits of approximately RMB8,084,000 in relation to the acquisition of Nanjing Dianya Property Management Company Limited (南京典雅物業管理有限公司), Tielin Zhennan Property Management Company Limited (鐵嶺正南物業管理有限公司), Qinghuangdao Hongtianyuan Property Company Limited (秦皇島市宏添源物業公司), Shanghai Tongyi Property Management Company Limited (上海通翼物業有限公司) and Liaoning Jixiang Baite Company Limited (遼寧吉祥百特有限公司) from independent third parties. The aforesaid companies are principally engaged in the PRC property management. At the date these consolidated financial statements were authorised for issue, the acquisitions have not been completed.

## **24. Deposits Paid for Acquisition of a Property Project**

During the year ended 31 December 2010, the Group had made deposit of approximately RMB37,000,000 in relation to the acquisition of a property project from an independent property developer. During the year ended 31 December 2011, the Group has made additional deposits of approximately RMB67,900,000 for acquiring the aforesaid property project.

The aforesaid deposit relates to acquisition of a building for hotel operations and is therefore classified as non-current assets.

At the date these consolidated financial statements were authorised for issue, the acquisition of a property project has not been completed.

## NOTES TO THE CONSOLIDATED FINANCIAL STATEMENTS

For the year ended 31 December 2011

### 25. Goodwill

	RMB'000
<b>COST</b>	
At 1 January 2010	24,820
Arising on acquisition of business (note 38(b))	5,375
At 31 December 2010 and 1 January 2011	30,195
Arising on acquisition of business (note 38(b))	1,321
At 31 December 2011	31,516
<b>IMPAIRMENT</b>	
At 1 January 2010	24,820
Impairment loss recognised for the year	5,375
At 31 December 2010 and 1 January 2011	30,195
Impairment loss recognised for the year	1,321
At 31 December 2011	31,516
<b>CARRYING AMOUNTS</b>	
At 31 December 2011	–
At 31 December 2010	–

During the year ended 31 December 2011, the Group acquired 100% equity interests in Tianjing Xintang Property Management Company Limited (“Tianjing Xingtang”), 51% equity interests in Shenzhen Robert Housekeeper Property Management Company Limited (“Shenzhen Robert”) and 100% equity interests in Huizhou Youling Property Management Company Limited (“Huizhou Youling”) from the independent third parties at a total cash consideration of approximately RMB1,178,000 (note 38(b)). Tianjing Xintang, Shenzhen Robert and Huizhou Youling are principally engaged in provision of property operation services and was acquired with the objective of expansion of property operation services.

On 31 March 2010, the Group acquired 75% equity interests in Shenzhen Hui Gang Property Management Company Limited (“Shenzhen Hui Gang”) from an independent third party at a consideration of approximately RMB5,500,000 (note 38(b)). Shenzhen Hui Gang is principally engaged in provision of property operation services and was acquired with the objective of expansion of property operation services.

Goodwill acquired in a business combination is allocated, at acquisition, to the cash generating units (“CGUs”) that are expected to benefit from that business combination.

## 26. Impairment Testing on Goodwill

In the opinion of the directors, the performance of Tianjing Xintang, Shenzhen Robert and Huizhou Youling in the future years assessed at the end of the reporting period is not as good as expected at the time of the acquisition due to the vigorous competition among other competitors and therefore impairment loss of RMB1,321,000 (2010: RMB5,375,000) is recognised during the year.

For the purposes of impairment testing, goodwill set out in note 25 has been allocated to one individual CGU, which is engaged in provision of property operation services. The carrying amount of goodwill (net of accumulated impairment losses) as at 31 December 2011 allocated to this CGU is nil (2010: nil).

## 27. Deferred Taxation

The following are the major deferred tax liabilities (assets) recognised and movements during the current and prior year are as follow:

	Fair value adjustment of investment properties RMB'000	Revaluation of properties RMB'000	Temporary difference on accruals RMB'000	Tax losses RMB'000	Others (note) RMB'000	Total RMB'000
At 1 January 2010	77,909	–	(6,934)	(47,749)	(79,764)	(56,538)
Charge (credit) to profit or loss	96,947	–	4,849	21,246	(88,242)	34,800
Underprovision of deferred tax assets	–	–	(166)	–	(7,479)	(7,645)
At 31 December 2010 and 1 January 2011	174,856	–	(2,251)	(26,503)	(175,485)	(29,383)
Charge to other comprehensive income	–	2,949	–	–	–	2,949
Charge (credit) to profit or loss	93,225	–	(8,519)	(40,191)	(25,747)	18,768
Underprovision of deferred tax assets	–	–	–	–	(813)	(813)
At 31 December 2011	268,081	2,949	(10,770)	(66,694)	(202,045)	(8,479)

Note: Others mainly represents the deductible temporary difference arising from LAT provision.

For the purpose of presentation in the consolidated statement of financial position, certain deferred taxation assets and liabilities has been offset. The following is the analysis of the deferred taxation balances for financial reporting purposes:

	2011 RMB'000	2010 RMB'000
Deferred tax assets	(220,826)	(157,504)
Deferred tax liabilities	212,347	128,121
	(8,479)	(29,383)

## NOTES TO THE CONSOLIDATED FINANCIAL STATEMENTS

For the year ended 31 December 2011

### 27. Deferred Taxation (continued)

At 31 December 2011, the Group had unutilised tax losses of approximately RMB729,686,000 (2010: RMB355,677,000). A deferred tax asset has been recognised in respect of approximately RMB266,776,000 (2010: RMB106,032,000) of such tax losses. No deferred tax asset has been recognised in respect of the remaining tax losses of RMB462,910,000 (2010: RMB249,645,000) due to the unpredictability of future profits streams. Pursuant to the relevant laws and regulations in the PRC, the unrecognised tax losses at the end of the reporting period will expire in the following years:

	2011 RMB'000	2010 RMB'000
2011	–	1,922
2012	31,839	33,965
2013	18,102	21,780
2014	15,384	15,384
2015	116,575	139,014
2016	237,025	–
No expiry	43,985	37,580
	462,910	249,645

At 31 December 2011, the aggregate amount of temporary differences associated with undistributed earnings of subsidiaries, for which deferred tax liabilities have not been recognised, was approximately RMB3,266,386,000 (2010: RMB1,783,074,000). No liability has been recognised in respect of these temporary differences because the Group is in a position to control the timing of the reversal of the temporary difference and it is probable that such differences will not reverse in the foreseeable future.

### 28. Properties for Sale

	2011 RMB'000	2010 RMB'000
Completed properties for sale	1,732,813	1,151,391
Properties under development for sale	8,489,507	6,493,191
	10,222,320	7,644,582

At 31 December 2011, certain of the Group's properties for sale with a carrying amount of RMB1,434,836,000 (2010: RMB2,048,054,000) were pledged to secure certain banking facilities granted to the Group.

At 31 December 2010, the Group was in the process of obtaining the land use right certificates for certain properties with an aggregate carrying amount of approximately RMB7,830,000 (2011: Nil).

During the year ended 31 December 2010, the Group had completed the acquisition of a property project from an independent property developer amounting to approximately RMB352,056,000 (2011: Nil).

During the year ended 31 December 2011, RMB56,176,000 (2010: RMB142,625,000) and RMB7,110,000 (2010: RMB2,957,000) were transferred to construction in progress under property, plant and equipment and prepaid lease payments, respectively, as a result of change in intended use to operate hotel business and for self used buildings as approved by the management of the Group.

## 28. Properties for Sale (continued)

During the year ended 31 December 2011, completed properties for sale with an aggregate amount of approximately RMB54,975,000 (2010: RMB39,230,000) were transferred to investment properties upon signing of relevant tenancy agreements. The excess of the fair value of these properties at the date of transfer over their carrying amounts, amounting to approximately RMB191,142,000 (2010: RMB67,326,000) were recognised in the consolidated statement of comprehensive income.

Included in the amount are properties under development for sale of approximately RMB2,451,117,000 (2010: RMB1,328,233,000) in relation to property development projects that are expected to complete after one year from the end of the reporting periods.

## 29. Trade and Other Receivables

Trade receivables are mainly arisen from sales of properties, rental income derived from investment properties, agency fee income in respect of property rentals, service and management income in respect of property management.

Considerations in respect of properties sold are received in accordance with the terms of the related sales and purchase agreements, normally within 30–90 days from date of delivery of the properties to the customers under the sales and purchase agreements.

Rental income from investment properties is received in accordance with the terms of the relevant lease agreements, normally within 30 days from the issuance of invoices.

Management and service fee income is received in accordance with the terms of the relevant property service agreements, normally within 30–90 days from the issuance of invoices.

Hotel operation income is in the form of cash sales.

	2011 RMB'000	2010 RMB'000
Trade receivables	410,171	116,301
Other receivables	93,568	90,403
Prepayments and other deposits	57,032	44,733
Prepayments for suppliers	280,925	336,598
Prepayments for construction work	293,111	339,971
Other tax prepayment (Note)	81,570	49,173
	1,216,377	977,179

Notes: During the year ended 31 December 2011, the Group is required to prepay business tax amounting to approximately RMB142,902,000 (2010: RMB159,252,000) in accordance with the relevant PRC tax rules in respect of its pre-sale of property development projects. As at 31 December 2011, amount of approximately RMB81,029,000 (2010: RMB48,938,000) has been prepaid and included in other tax prepayment.

Included in prepayments for construction work are amounts of approximately RMB23,486,000 (2010: RMB28,287,000) in relation to property development projects that are expected to be completed after one year from the end of the reporting periods.

## NOTES TO THE CONSOLIDATED FINANCIAL STATEMENTS

For the year ended 31 December 2011

### 29. Trade and Other Receivables (continued)

The following is an aged analysis of trade receivables of the Group net of allowance for doubtful debts presented based on the invoice date at the end of the reporting period:

	2011 RMB'000	2010 RMB'000
0 to 30 days	214,728	87,063
31 to 90 days	150,069	10,229
91 to 180 days	25,401	5,544
181 to 365 days	16,072	10,576
Over 1 year	3,901	2,889
	410,171	116,301

For property investment and property operating services, before accepting any new customer, the Group would assess the potential customer's credit quality and defined credit rating limits of each customers. Limits attributed to customers are reviewed once a year.

In determining the recoverability of a trade receivable, the Group considers any change in the credit quality of the trade receivable from the date credit was initially granted up to the reporting date and no impairment is necessary for those balances which are not past due.

At 31 December 2011, included in the Group's trade receivable balance are debtors with aggregate carrying amount of approximately RMB45,374,000 (2010: RMB19,009,000) which are past due for which the Group has not provided for impairment loss as there has not been a significant change in credit quality and amounts are still considered recoverable based on historical experience. The Group does not hold any collateral over these balances.

#### Ageing of trade receivables which are past due but not impaired

	2011 RMB'000	2010 RMB'000
91 to 180 days	25,401	5,544
181 to 365 days	16,072	10,576
Over 1 year	3,901	2,889
	45,374	19,009



## 29. Trade and Other Receivables (continued)

### Movement in the allowance for doubtful debts in respect of trade and other receivables

	2011 RMB'000	2010 RMB'000
Balance at the beginning of the year	2,937	1,520
Impairment losses reversed	(2,812)	(103)
Impairment losses written off	–	(1,520)
Impairment losses recognised	2,547	3,040
Balance at the end of the year	2,672	2,937

As at 31 December 2011, included in the allowance for doubtful debts are individually impaired trade and other receivables with an aggregate balance of RMB2,672,000 (2010: RMB2,937,000) of which the debtors have been in dispute with the Group.

## 30. Amounts Due from Related Parties

	2011 RMB'000	2010 RMB'000
深圳市天闊投資發展有限公司 Shenzhen Tiankuo Investment Development Company Limited (“Shenzhen Tiankuo”) (note i)	3,262	–
惠州市國勝土石方工程有限公司 Huizhou Guosheng Tushifang Industry Company Limited (“Huizhou Guosheng”) (note ii)	–	7,500
	3,262	7,500

#### Notes:

- (i) The balance represents the advance to Shenzhen Tiankuo, a related company controlled by Ms. Zeng Jie, Baby, the controlling shareholder and director of the Company. The amount is unsecured, non-interest bearing and is non-trade nature.
- (ii) The balance represented the prepayment for construction work in a property development for sale project and accordingly classified as trade nature. The balance was fully settled during the year ended 31 December 2011.

## NOTES TO THE CONSOLIDATED FINANCIAL STATEMENTS

For the year ended 31 December 2011

### 31. Amounts Due from Customers For Contract Works

	2011 RMB'000	2010 RMB'000
Contract costs incurred plus recognised profits less recognised losses	112,415	55,034
Less: Progress billings	(96,056)	(39,095)
	16,359	15,939

No retentions held by customers for contract works for installation contracts was included in amounts due from customers for contract works.

No advance from customers prior to commencement of contract works had been received during the years ended 31 December 2011 and 2010.

### 32. Restricted Bank Deposits/Bank Balances and Cash

#### Restricted bank deposits

The deposits carry interest rates ranging from 0.36% to 0.5% (2010: 0.36% to 0.72%) per annum. The restricted bank deposits amounting to approximately RMB62,198,000 (2010: RMB85,161,000) will be released upon the buyers obtaining the individual property ownership certificate, while a total amount RMB252,936,000 (2010: nil) are proceeds from presale of properties with the restriction on settlement of construction costs for relevant property projects.

#### Bank balances and cash

The bank balances carry variable interest rates ranging from 0.36% to 3.10% (2010: 0.36% to 2.25%) per annum.

At 31 December 2011, bank balances of the Group denominated in USD, HKD and TWD foreign currencies of the relevant group entities, are approximately RMB5,195,000 (2010: RMB17,376,000), RMB288,798,000 (2010: RMB520,692,000) and RMB3,496,000 (2010: Nil), respectively.

### 33. Trade and Other Payables

	2011 RMB'000	2010 RMB'000
Trade payables	1,696,289	1,319,641
Other payables	254,332	220,721
Other tax payables	104,674	36,520
Payroll payable	50,403	20,192
Welfare payable	695	2,895
Retention payable	29,330	16,442
Consideration payable (note 38)	128,267	63,900
Accruals	4,839	6,407
	2,268,829	1,686,718

Trade payables principally comprise amounts outstanding for purchase of materials for the construction of properties for sale and ongoing expenditures. The average credit period for purchase of construction materials ranged from 6 months to 1 year.

### 33. Trade and Other Payables (continued)

The following is an aged analysis of the Group's trade payables and retention payable presented based on the invoice date at the end of the reporting period:

	2011 RMB'000	2010 RMB'000
0 to 60 days	1,325,615	881,583
61 to 180 days	261,680	346,243
181 to 365 days	23,344	67,903
1-2 years	94,931	37,944
2-3 years	16,238	1,272
Over 3 years	3,811	1,138
	1,725,619	1,336,083

At 31 December 2011, the balances of approximately RMB29,330,000 (2010: RMB16,442,000) with age over 1 year represent the retention money of approximately 5% to 10% of the construction contract price.

### 34. Amounts Due to Related Parties

	2011 RMB'000	2010 RMB'000
深圳立方建築設計顧問有限公司 Shenzhen Cube Architecture Designing Consultants Company Limited ("Cube Architecture") (Note i)	2,547	–
天津松江集團有限公司 Tianjin Songjiang Group Company Limited ("Songjiang Group") (Note ii)	–	100,549
	2,547	100,549

Notes:

- (i) Cube Architecture is the associate of Shenzhen Tiankuo (defined in note 30), a related company controlled by Ms. Zeng Jie, Baby, the controlling shareholder and director of the Company. The amount is unsecured, non-interest bearing and represents the payable's to Shenzhen Tiankuo for the design fee for several property projects of the Group, and accordingly classified as trade nature. The average aging of the balance is within 90 days.
- (ii) Songjiang Group held 40% equity interests in a subsidiary of the Company. The amount was non-trade nature with interest bearing at 7.02% per annum and was fully repaid during the year ended 31 December 2011.

## NOTES TO THE CONSOLIDATED FINANCIAL STATEMENTS

For the year ended 31 December 2011

### 35. Borrowings

	2011 RMB'000	2010 RMB'000
Bank loans	4,273,002	4,306,986
Other loans	468,000	468,000
	4,741,002	4,774,986
Secured	4,711,002	4,206,986
Unsecured	30,000	568,000
	4,741,002	4,774,986
<i>Carrying amount repayable*:</i>		
Within one year	1,896,308	1,933,270
More than one year, but not exceeding two years	1,216,000	1,860,000
More than two years, but not exceeding five years	936,824	875,861
More than five years	691,870	105,855
	4,741,002	4,774,986
Less: Carrying amount of bank loans that are not repayable within one year from the end of the reporting period but contain a repayment on demand clause (shown under current liabilities)	(203,761)	(199,111)
Less: Amounts due within one year shown under current liabilities	(1,896,308)	(1,933,270)
	2,640,933	2,642,605

\* The amounts due are based on scheduled repayment dates set out in the loan agreements.

At 31 December 2011, all borrowings are denominated in RMB except that secured borrowings amounting to approximately RMB844,321,000 (2010: RMB662,270,000) and RMB163,762,000 (2010: RMB199,111,000) are denominated in USD and HKD respectively, foreign currency of relevant group entities.

The analysis of the Group's fixed-rate borrowings based on their contractual maturity dates are as follows:

	2011 RMB'000	2010 RMB'000
Fixed-rate borrowings:		
Within one year	–	100,000
More than one year, but not exceeding two years	–	220,000
	–	320,000

### 35. Borrowings (continued)

In addition, the Group has variable-rate borrowings which carry interest linked to LIBOR, HIBOR and Benchmark Rate. Interest is repriced every six months. The analysis of the Group's variable rate borrowings based on their contractual maturity dates are as follows:

	2011 RMB'000	2010 RMB'000
Variable-rate borrowings:		
Within one year	1,896,308	1,833,270
More than one year, but not exceeding two years	1,216,000	1,640,000
More than two years, but not exceeding five years	936,824	875,861
More than five years	691,870	105,855
	4,741,002	4,454,986

The ranges of effective interest rates (which are the contracted interest rates) on the Group's borrowings are as follows:

	2011	2010
Effective interest rate:		
Fixed-rate borrowings	N/A	5.37% per annum
Variable-rate borrowings		
LIBOR	+2% per annum	+2% per annum
HIBOR	+2% per annum	+2% per annum
Benchmark Rate	-1.52% to +5.85% per annum	-1.03% to +7.10% per annum

## NOTES TO THE CONSOLIDATED FINANCIAL STATEMENTS

For the year ended 31 December 2011

### 36. Senior Notes

On 12 May 2010, the Company issued senior notes in an aggregate principal amount of US\$120,000,000 (the "Notes"). The issue price is 98.264% of the principal amount of the Notes. The Notes are listed on the Singapore Exchange Securities Trading Limited. The Notes carry interest of 14% per annum and interest is payable semi-annually on 12 May and 12 November in arrears. The Notes will mature on 12 May 2015, unless redeemed earlier.

At any time, the Company may at its option redeem the Notes, in whole but not in part, at a redemption price equal to 100% of the principal amount of the Notes plus applicable premium as defined in the offering memorandum of the Company dated 5 May 2010 ("Applicable Premium") as of, and accrued and unpaid interest, if any to (but not including) the redemption date.

Applicable premium is the greater of (1) 1% of the principal amount of such Notes and (2) the excess of the amount equivalent to the principal amount and related interest up to 12 May 2015 discounted at a rate equal to comparable treasury price in United States plus 100 basis points over the principal amount.

At any time and from time to time prior to 12 May 2013, the Company may redeem up to 35% of the aggregate principal amount of the Notes with the net cash proceeds of one or more sales of ordinary shares of the Company in an equity offering at a redemption price of 114% of the principal amount of the Notes, plus accrued and unpaid interest, if any, to (but not including) the redemption date.

The Notes contain a liability component and the above early redemption options:

- (i) Liability component represents the present value of the contractually determined stream of future cash flows discounted at the prevailing market interest rate at that time applicable to instruments of comparable credit status and providing substantially the same cash flows, on the same terms, but without the embedded derivatives.

The interest charged for the year is calculated by applying an effective interest rate of approximately 14.89% per annum to the liability component since the Notes were issued.

- (ii) Early redemption options are regarded as embedded derivatives not closely related to the host contract. The directors consider that the fair value of the above early redemption options is insignificant on initial recognition and at 31 December 2011.

The movements of the liability component in the Notes during the years are set out below:

	RMB'000	RMB'000
Carrying amount as at 1 January	787,330	794,076
Exchange gains	(38,384)	(23,777)
Interest expenses	113,413	74,589
Less: Interest paid to Notes holders	(109,992)	(57,558)
Carrying amount as at 31 December	752,367	787,330

The fair value of the Notes at 31 December 2011 amounted to approximately RMB593,482,000. (2010: RMB812,539,000) The fair value is calculated using the market price of the Notes at the end of reporting period (or the nearest day of trading).

### 37. Share Capital

	Number of shares	Amount HK\$	Equivalent to RMB'000
Ordinary shares of HK\$0.1 each			
Authorised:			
At 1 January 2010, 31 December 2010, 1 January 2011 and 31 December 2011	8,000,000,000	800,000,000	704,008
Issued and fully paid:			
At 1 January 2010, 31 December 2010, 1 January 2011	4,873,888,750	487,388,875	429,389
Subscription of new shares (Note)	333,333,000	33,333,300	27,704
At 31 December 2011	5,207,221,750	520,722,175	457,093

Note: On 24 June 2011, the Company and the former non-controlling shareholder of a subsidiary ("Subscriber") entered into a subscription agreement, which the Subscriber has agreed to subscribe for the subscription shares ("Subscription Shares") at a total subscription amount of RMB332,440,000. The issue price of the Subscription Shares is HK\$1.2 per share which is determined with reference to the share price quoted on The Stock Exchange of Hong Kong Limited on 24 June 2011.

The Subscription Shares represent approximately 6.84% of the then existing issued share capital of the Company as at 24 June 2011 and approximately 6.4% of the enlarged issued share capital of the Company immediately after issue of the Subscription Shares. The Company intends to use the proceeds to finance continuing capital expenditure requirements and as general working capital for the Group's operating activities.

On 30 June 2011, total 333,333,000 Subscription Shares have been allotted and issued by the Company.

These new issued shares rank pari passu with existing shares.

## NOTES TO THE CONSOLIDATED FINANCIAL STATEMENTS

For the year ended 31 December 2011

### 38. Acquisition of Subsidiaries

#### (a) Acquisition of assets and liabilities through acquisition of subsidiaries

##### *For the year ended 31 December 2011*

On 19 August 2011, the Group acquired the assets and liabilities of a property project through the acquisition of 100% equity interests in TCL King Electronics (Shenzhen) Company Limited (TCL王牌電子(深圳)有限公司) from independent third parties at a cash consideration of approximately RMB309,345,000.

The above transaction was accounted for as purchase of assets and liabilities. Details of the net assets acquired in respect of the above transactions is summarised below:

	RMB'000
Net assets acquired	
Prepaid lease payments	19,547
Premium on prepaid lease payments	187,956
Other receivables	30,231
Amount due from Fantasia group company	70,000
Bank balances and cash	1,777
Other payables	(166)
	309,345
Total consideration satisfied by:	
Cash	182,000
Consideration payable due for settlement within one year	127,345
	309,345
Net cash (outflow) inflow arising on acquisition	
Cash consideration paid during the year	(182,000)
Bank balances and cash acquired	1,777
	(180,223)

##### *For the year ended 31 December 2010*

On 20 April 2010, the Group acquired the assets and liabilities of a property project through the acquisition of 100% equity interests in Suzhou Huawanli Real Estate Company Limited (蘇州花萬里房地產開發有限公司) from independent third parties at a consideration of approximately RMB219,215,000.

On 20 April 2010, the Group acquired the assets and liabilities of a property project through the acquisition of 100% equity interests in Suzhou LKN Real Estate Company Limited (蘇州林甲岩房產發展有限公司) from independent third parties at a consideration of approximately RMB226,383,000.

On 30 June 2010, the Group acquired the assets and liabilities of a property project through the acquisition of 100% equity interests in Dongguan Huaqianli Property Development Company Limited (東莞花千里房地產開發有限公司) from independent third parties at a consideration of approximately RMB10,000,000.

On 30 June 2010, the Group acquired the assets and liabilities of a property project through the acquisition of 100% equity interests in Shenzhen Gaohua Investment Limited (深圳高華投資有限公司) and its subsidiaries from independent third parties at a consideration of approximately RMB200,000,000.

On 7 September 2010, the Group acquired the assets and liabilities of a property project through the acquisition of 100% equity interests in Chengdu Nuoyazhou Development Company Limited (成都市諾亞舟實業有限公司) from independent third parties at a consideration of approximately RMB100,000,000.



### 38. Acquisition of Subsidiaries (continued)

#### (a) Acquisition of assets and liabilities through acquisition of subsidiaries (continued)

##### *For the year ended 31 December 2010* (continued)

On 17 December 2010, the Group acquired the assets and liabilities of a property project through the acquisition of 100% equity interest in Jiangsu Dongfa Real Estate Company Limited (江蘇東發置業有限公司) from independent third parties at a consideration of approximately RMB20,000,000.

On 24 December 2010, the Group acquired the assets and liabilities of a property project through the acquisition of 100% equity interests in Guilin Wanhao Property Development Limited (桂林萬豪房地產開發有限公司) from independent third parties at a consideration of approximately RMB153,144,000.

On 24 December 2010, the Group acquired the assets and liabilities of a property project through the acquisition of 100% equity interests in Guilin Juhao Property Development Limited (桂林聚豪房地產開發有限公司) from independent third parties at a consideration of approximately RMB176,197,000.

In addition to the considerations set out above, the Group made an aggregate payment of RMB827,250,000 owed by the acquirees to the respective vendors as at the date of the acquisition. The aforesaid amounts formed part of the consideration paid for the above acquisitions.

The above transaction was accounted for as purchase of assets and liabilities. Details of the net assets acquired in respect of the above transaction were summarised below:

	RMB'000
Net assets acquired	
Property, plant and equipment	362
Investment properties	6,717
Prepaid lease payments	1,008,907
Premium on prepaid lease payments	814,509
Completed properties for sale	15,460
Properties under development for sale	45,793
Other receivables	18,292
Tax recoverable	1,487
Bank balances and cash	33,963
Other payables	(13,301)
	1,932,189
Total consideration satisfied by:	
Cash	1,445,289
Deposits paid for acquisition of subsidiaries	423,000
Consideration payable settled in 2011	63,900
	1,932,189
Net cash (outflow) inflow arising on acquisition	
Cash consideration paid during the year	(1,445,289)
Bank balances and cash acquired	33,963
	(1,411,326)

## NOTES TO THE CONSOLIDATED FINANCIAL STATEMENTS

For the year ended 31 December 2011

### 38. Acquisition of Subsidiaries (continued)

#### (b) Acquisition of business

##### *For the year ended 31 December 2011*

On 19 April 2011, the Group acquired 100% equity interests in Tianjin Xingtang Property Management Company Limited 天津新塘物業管理有限公司 (“Tianjin Xintang”) from an independent third party at a consideration of approximately RMB78,000. Tianjin Xingtang is principally engaged in provision of property operation services and was acquired with the objective of expansion of property operation services.

On 1 July 2011, the Group acquired 100% equity interests in Huizhou Youling Property Management Company Limited 惠州友鄰物業管理有限公司 (“Huizhou Youling”) from an independent third party at a consideration of approximately RMB500,000. Huizhou Youling is principally engaged in provision of property operation services and was acquired with the objective of expansion of property operation services.

On 12 July 2011, the Group acquired 51% equity interests in Shenzhen Robert Housekeeper Property Management Company Limited 羅伯特管理物業管理有限公司 (“Shenzhen Robert”) from an independent third party at a consideration of approximately RMB600,000. Shenzhen Robert is principally engaged in provision of property operation services and was acquired with the objective of expansion of property operation services.

##### *Consideration transferred*

	RMB'000
Cash	256
Other payables	922
<b>Total</b>	<b>1,178</b>

Acquisition-related costs were insignificant and have been excluded from the cost of acquisition and have been recognised as an expense in the period within the “administrative expenses” line item in the condensed consolidated statement of comprehensive income.

Assets acquired and liabilities recognised at the date of acquisition are as follows:

	RMB'000
Property, plant and equipment	18
Other receivables	1,157
Bank balances and cash	1,078
Trade and other payables	(2,629)
Tax payable	(27)
	<b>(403)</b>

The other receivables acquired with a fair value of approximately RMB1,157,000 had gross contractual amounts of approximately RMB1,157,000.

### 38. Acquisition of Subsidiaries (continued)

#### (b) Acquisition of business (continued)

*For the year ended 31 December 2011 (continued)*

*Goodwill arising on acquisition*

	RMB'000
Consideration transferred	1,178
Plus: non-controlling interests	(260)
Less: fair value of net liabilities acquired	403
Goodwill arising on acquisition	1,321

The non-controlling interests amounting to approximately RMB260,000, was measured by reference to the proportionate share of the 49% of Shenzhen Robert's net identifiable liabilities at the acquisition date.

Goodwill arose on the acquisition of Tianjing Xingtang, Huizhou Youling and Shenzhen Robert because the acquisition included the control premium and the future profitability as at acquisition date. These benefits could not be separately recognised from goodwill because they do not meet the recognition criteria for identifiable intangible assets.

None of the goodwill arising on this acquisition is expected to be deductible for tax purposes.

*Net cash inflow arising on acquisition*

	RMB'000
Cash consideration paid	(256)
Bank balances and cash acquired	1,078
	822

*Impact of acquisition on the results of the Group*

Included in the profit for the year ended 31 December 2011 is approximately RMB117,000 attributable to the additional businesses generated by Tianjing Xingtang, Huizhou Youling and Shenzhen Robert in total. Revenue for the year includes approximately RMB4,396,000 generated from Tianjing Xingtang, Huizhou Youling and Shenzhen Robert in total.

Had the above acquisition been completed on 1 January 2011, the revenue of the Group for the year ended 31 December 2011 would have been approximately RMB5,594,993,000, and the profit for the year would have been approximately RMB1,209,661,000.

The proforma information is for illustrative purposes only and is not necessarily an indication of revenue and results of operations of the Group that actually would have been achieved had the acquisition been completed at 1 January 2011, nor is intended to be a projection of future results.

## NOTES TO THE CONSOLIDATED FINANCIAL STATEMENTS

For the year ended 31 December 2011

### 38. Acquisition of Subsidiaries (continued)

#### (b) Acquisition of business (continued)

##### *For the year ended 31 December 2010*

On 31 March 2010, the Group acquired 75% equity interests in Shenzhen Hui Gang from an independent third party at a consideration of approximately RMB5,500,000.

Shenzhen Hui Gang principally engaged in provision of property operation services and was acquired with the objective of expansion of property operation services.

##### *Consideration transferred*

	RMB'000
Cash	5,500

Acquisition-related costs were insignificant and have been excluded from the cost of acquisition and have been recognised as an expense in the period within the "administrative expenses" line item in the consolidated statement of comprehensive income.

##### *Assets and liabilities recognised at the date of acquisition*

	RMB'000
Net assets acquired	
Property, plant and equipment	875
Other receivables	227
Bank balances and cash	4,092
Trade and other payables	(4,948)
Tax payable	(79)
	167

The other receivables acquired with a fair value of approximately RMB227,000 had gross contractual amounts of approximately RMB227,000.

### 38. Acquisition of Subsidiaries (continued)

#### (b) Acquisition of business (continued)

*For the year ended 31 December 2010* (continued)

##### *Non-controlling interests*

The non-controlling interests in Shenzhen Hui Gang amounting to approximately RMB42,000, was measured by reference to the proportionate share of the acquiree's net identifiable assets at the acquisition date.

##### *Goodwill arising on acquisition*

	RMB'000
Consideration transferred	5,500
Plus: non-controlling interests	42
Less: fair value of net identifiable assets acquired	(167)
Goodwill arising on acquisition	5,375

Goodwill arose on the acquisition of Shenzhen Hui Gang because the acquisition included the future profitability of Shenzhen Hui Gang as at acquisition date. These assets could not be separately recognised from goodwill because they are not capable of being separated from Shenzhen Hui Gang and sold, transferred, licensed, rented or exchanged, either individually or together with any related contracts.

None of the goodwill arising on this acquisition was expected to be deductible for tax purposes.

##### *Net cash outflow arising on acquisition*

	RMB'000
Cash consideration paid	(5,500)
Bank balances and cash acquired	4,092
	(1,408)

##### *Impact of acquisition on the results of the Group*

Included in the profit for the year is RMB974,000 attributable to the additional business generated by Shenzhen Hui Gang. Revenue for the year includes approximately RMB5,694,000 generated from Shenzhen Hui Gang.

Had the above acquisition been completed on 1 January 2010, total group revenue for the year would have been approximately RMB4,473,011,000, and profit for the year would have been approximately RMB961,594,000.

The proforma information is for illustrative purposes only and is not necessarily an indication of revenue and results of operations of the Group that actually would have been achieved had the acquisition been completed on 1 January 2010, nor is it intended to be a projection of future results.

## NOTES TO THE CONSOLIDATED FINANCIAL STATEMENTS

For the year ended 31 December 2011

### 39. Disposal of a Subsidiary

For the year ended 31 December 2011

On 14 February 2011, the Group disposed of its entire 85% equity interests in Shenzhen Xingyan Property Consultancy Company Limited (深圳市星彥地產顧問有限公司) ("Shenzhen Xingyan") to an independent third party for a consideration of approximately RMB21,250,000. Shenzhen Xingyan was engaged in provision of property agency services.

	RMB'000
<b>Consideration satisfied by:</b>	
Cash	14,875
Consideration receivable	6,375
	21,250
<b>Analysis of assets and liabilities over which control was lost:</b>	
Property, plant and equipment	1,700
Trade and other receivables	2,415
Amounts due from group companies	5,531
Bank balances and cash	3,184
Trade and other payables	(7,256)
Tax payable	(1,267)
	4,307
<b>Gain on disposal of a subsidiary:</b>	
Cash consideration	14,875
Consideration receivable	6,375
Non-controlling interests	646
Net assets disposed of	(4,307)
	17,589
<b>Net cash inflow arising on disposal:</b>	
Cash consideration	14,875
Bank balances and cash disposed of	(3,184)
	11,691

The subsidiary disposed of did not contribute significantly to the Group's cash flows, revenue and profit from operations during the year ended 31 December 2011.

#### 40. Operating Lease Commitments

##### The Group as lessee

At the end of the reporting period, the Group had commitments for future minimum lease payments under non-cancellable operating leases which fall due as follows:

	2011 RMB'000	2010 RMB'000
Within one year	7,022	7,195
In the second to the fifth year inclusive	18,428	20,037
After the fifth year	5,638	10,190
	31,088	37,422

Operating lease payments represent rentals payable by the Group for certain offices premises. Leases are negotiated for an average term of 1 to 10 years with fixed rentals.

##### The Group as lessor

At the end of the reporting period, the Group has contracted with tenants for the following future minimum lease payments:

	2011 RMB'000	2010 RMB'000
Within one year	50,426	14,960
In the second to the fifth year inclusive	174,104	50,530
After the fifth year	106,234	115,668
	330,764	181,158

Property rental income represents rentals receivable by the Group. Leases are negotiated for an average term of 1 to 18 years with fixed rentals.

#### 41. Other Commitments

	2011 RMB'000	2010 RMB'000
Construction commitments in respect of properties for sale contracted for but not provided in the consolidated financial statements	2,525,242	1,631,646
Land development expenditure commitments in respect of development cost contracted for but not provided in the consolidated financial statements	98,202	–
Construction commitments in respect of investment properties contracted for but not provided in the consolidated financial statements	206,353	50,366
Construction commitments in respect of hotels contracted for but not provided in the consolidated financial statements	41,646	83,455
Consideration commitments in respect of acquisition of subsidiaries contracted for but not provided in the consolidated financial statements	4,521	–
Commitment in respect of acquisition of land use rights contracted for but not provided in the consolidated financial statements	–	140,000

## NOTES TO THE CONSOLIDATED FINANCIAL STATEMENTS

For the year ended 31 December 2011

### 42. Share Option Scheme

The Company's share option scheme (the "Scheme") was adopted pursuant to a resolution passed on 27 October 2009 for the primary purposes of providing incentives to certain directors and employees of the Company and its subsidiaries ("Eligible Employees"), and will expire on 28 August 2021. Under the Scheme, the Board of Directors of the Company is authorised to grant options at a consideration of HK\$1 per option to the Eligible Employees to subscribe for shares in the Company ("Shares").

The maximum number of Shares which may be issued upon exercise of all options to be granted under the Scheme ("Options") and any other share option schemes of the Company shall not, in the absence of shareholders' approval, in aggregate exceed 10% of the shares of the Company in issue at any point in time. Options granted to a substantial shareholder or an independent non-executive director in excess of 0.1% of the Company's share capital or with a value in excess of HK\$5 million must be approved in advance by the Company's shareholders.

The exercisable period of an option is determined by the directors at their discretion. The expiry date of the option may be determined by the Board of Directors of the Company which shall not be later than the expiry day of the Scheme.

The exercise price is determined by the directors of the Company, and will not be less than the greater of: (i) the closing price of the Company on the offer date; (ii) the average of the closing price of the Company's shares for the 5 trading days immediately preceding the offer of the options and (iii) the nominal value per share of the Company.

As at 31 December 2011, the total number of shares to be issued upon the exercise of all options granted under the Scheme is 74,230,000 of HK\$0.1 each, representing approximately 1.43% of the issued share capital of the Company.

Details of the share options granted under the Scheme during the year ended 31 December 2011 is as follows:

Category of Grantee	Date of grant	Exercise price per share	Exercisable period	Vesting period	Option granted during the year and at 31 December 2011
Directors	29 August 2011	HK\$0.836	29/08/2012–28/08/2021	29/08/2011–28/08/2012	2,201,000
			29/08/2013–28/08/2021	29/08/2011–28/08/2013	4,402,000
			29/08/2014–28/08/2021	29/08/2011–28/08/2014	15,407,000
					22,010,000
Employees	29 August 2011	HK\$0.836	29/08/2012–28/08/2021	29/08/2011–28/08/2012	5,222,000
			29/08/2013–28/08/2021	29/08/2011–28/08/2013	10,444,000
			29/08/2014–28/08/2021	29/08/2011–28/08/2014	36,554,000
					52,220,000

There is no share options exercised or expired during the year ended 31 December 2011.



#### 42. Share Option Scheme (continued)

The closing price of the shares on the date of grant was HK\$0.820. Binomial Option Pricing Model has been used to estimate the fair value of the options. The variables and assumptions used in computing the fair value of the share options are based on the Company's best estimate. The value of an option varies with different variables of certain subjective assumptions. The inputs into the model are as follows:

	29 August 2011
Market price	HK\$0.820
Exercise price	HK\$0.836
Expected volatility	40.43%
Risk-free rate	1.74%
Expected dividend yield	4.878%

The estimated fair value of the options at the date of grant and on 31 December 2011 is approximately RMB15,225,000. The Group recognised the total expense of approximately RMB2,240,000 for the year in relation to share options granted by the Company.

#### 43. Retirement Benefits Plans

The Group operates a mandatory Provident Fund Scheme for all qualifying employees in Hong Kong. The assets of the scheme are held separately from those of the Group, in funds under control of a trustee. The Group contributes lower of 5% of relevant payroll costs or HK\$1,000 per person per month to the Scheme, which is matched by employees.

The employees of the Group in the PRC are members of state-managed retirement benefit scheme operated by the PRC Government. The Company's subsidiary is required to contribute a certain percentage of payroll to the retirement benefit schemes to fund the benefits. The only obligation of the Group with respect to the scheme is to make the required contributions under the scheme.

#### 44. Contingent Liabilities

	2011	2010
	RMB'000	RMB'000
Guarantees given to banks for mortgage facilities granted to purchasers of the Group's properties	2,478,814	1,689,775

The Group had provided guarantees in respect of mortgage facilities granted by certain banks in connection with the mortgage loans entered into by purchasers of the Group's properties. Pursuant to the terms of the guarantees, if there is default of the mortgage payments by these purchasers, the Group is responsible to repay the outstanding mortgage loans together with accrued interests thereon and any penalty owed by the defaulted purchasers to banks. The Group is then entitled to take over the legal title of the related properties. The guarantee period commences from the dates of grant of the relevant mortgage loans and ends after the buyer obtained the individual property ownership certificate.

In the opinion of the directors, the fair value of guarantee contracts is insignificant at initial recognition. Also, no provision for the guarantee contracts at the end of the reporting period is recognised as the default risk is low.

## NOTES TO THE CONSOLIDATED FINANCIAL STATEMENTS

For the year ended 31 December 2011

### 45. Related Party Disclosures

- 1) During the year, in addition to those disclosed in notes 17, 18, 30 and 34, the Group had significant transactions with related parties as follows:

Related parties	Relationship	Transactions	2011 RMB'000	2010 RMB'000
Huidong Dayawan San Jiao Zhou Company Limited 惠東縣大亞灣三角洲俱樂部有限公司	Company controlled by Ms. Zeng Jie, Baby, a controlling shareholder and director of the Company	Management service fee	980	500
Shenzhen Xi Fu Hui Club Management Company Limited 深圳喜福會會所管理有限公司	Company controlled by Ms. Zeng Jie, Baby, a controlling shareholder and director of the Company	Property rental income received	301	301
Shenzhen Cube Architecture Designing Consultants Company Limited 深圳立方建築設計顧問有限公司	An associate of Shenzhen Tiankuo (defined in note 30), a related company controlled by Ms. Zeng Jie, Baby, the controlling shareholder and director of the Company	Design services fee paid	4,154	–
Mr. Yu Shui 于水先生	Non-controlling shareholder of a subsidiary of the Company	Consideration paid in respect of acquisition of additional interest in a subsidiary of the Group	332,440	–
Zhongxu Investment Limited 中旭投資有限公司	Non-controlling shareholder of a subsidiary of the Company	Consideration paid in respect of acquisition of additional interest in a subsidiary of the Group	10,000	–

During the year ended 31 December 2011, the Group sold certain properties to its key management personnel of the Group, at a cash consideration of approximately RMB6,459,000 (2010: RMB10,704,000).

2) **Compensation of key management personnel**

The remuneration of directors and other members of key management during the year is as follows:

	2011 RMB'000	2010 RMB'000
Short-term benefit	61,260	52,768
Post-employment benefit	2,663	1,353
Share-based payment	1,985	–
	65,908	54,121

#### 46. Particulars of Principal Subsidiaries of the Company

Particulars of principal subsidiaries indirectly held, unless otherwise stated, by the Company at 31 December 2011 and 2010 are as follows:

Name of subsidiary	Place and date of incorporation/ establishment	Issued and fully paid share/ registered capital	Proportion ownership interest held by the Group		Principal activities	Legal form
			2011	2010		
Winning Sky International Limited	The BVI 8 March 2006	US\$100	100% (directly)	100% (directly)	Investment holding	Private limited liability
Fantastic Victory Limited	The BVI 3 September 2007	US\$100	100% (directly)	100% (directly)	Investment holding	Private limited liability
Wisdom Regal Limited	The BVI 3 September 2007	US\$100	100% (directly)	100% (directly)	Investment holding	Private limited liability
Colour Life Services Group Co., Ltd ("Colour life Services")	The Cayman Islands 16 March 2011	HK\$1,000	70% (directly)	N/A	Investment holding	Private limited liability
Ace Link Pacific Limited #	The BVI 3 September 2007	US\$100	70%	100% (directly)	Investment holding	Private limited liability
Precise Idea Limited	The BVI 17 June 2009	US\$1	100% (directly)	100% (directly)	Investment holding	Private limited liability
Talent Bright International Limited	The BVI 17 June 2009	US\$1	100% (directly)	100% (directly)	Investment holding	Private limited liability
香港花樣年投資控股集團有限公司 Fantasia Investment Holdings Company Limited ("Fantasia Investment Holdings")	Hong Kong 19 February 2001	HK\$10,000	100%	100%	Investment holding	Private limited liability
悅泰投資有限公司 Joytime Investment Limited	Hong Kong 6 November 2007	HK\$10,000	100%	100%	Investment holding	Private limited liability
金展集團有限公司 Gold Genius Holdings Limited #	Hong Kong 8 November 2007	HK\$10,000	70%	100%	Investment holding	Private limited liability
花樣年酒店管理(國際)有限公司 Fantasia Hotel Management (International) Company Limited	Hong Kong 15 July 2009	HK\$1	100%	100%	Investment holding	Private limited liability
花樣年物業管理(國際)有限公司 Fantasia Property Management (International) Company Limited	Hong Kong 15 July 2009	HK\$1	100%	100%	Investment holding	Private limited liability

## NOTES TO THE CONSOLIDATED FINANCIAL STATEMENTS

For the year ended 31 December 2011

### 46. Particulars of Principal Subsidiaries of the Company (continued)

Name of subsidiary	Place and date of incorporation/ establishment	Issued and fully paid share/ registered capital	Proportion ownership interest held by the Group		Principal activities	Legal form
			2011	2010		
香港康年貿易有限公司 Hong Kong Kangnian Trading Company Limited	Hong Kong 24 September 2009	US\$500,000	100%	100%	Trading and investment holding	Private limited liability
花樣年集團(中國)有限公司 Fantasia Group (China) Company Limited*	The PRC 20 January 2006	RMB1,624,843,500	100%	100%	Investment holding and property development	Limited liability company
天津松江花樣年置業有限公司 Tianjin Songjiang Fantasia Real Estate Company Limited*	The PRC 29 May 2006	RMB50,000,000	60%	60%	Property development	Limited liability company
深圳市花樣年地產集團有限公司 Shenzhen Fantasia Real Estate Group Limited* ("Shenzhen Fantasia")	The PRC 28 September 1996	RMB100,000,000	100%	52%	Investment holding, property development and investment	Limited liability company
深圳市星彥地產顧問有限公司 Shenzhen Xingyan Property Consultancy Company Limited*	The PRC 21 February 2000	RMB3,000,000	–	85%	Provision of property agency services	Limited liability company
深圳市彩生活服务集團有限公司 Shenzhen Fantasia Colour Life Service Group Limited*	The PRC 25 August 2006	RMB15,000,000	70%	70%	Investment holding	Limited liability company
惠州大亞灣花萬里實業有限公司 Huizhou Daya Bay Huawanli Industry Company Limited*	The PRC 8 June 2007	RMB51,000,000	100%	100%	Property development	Limited liability company
天津市花樣年投資有限公司 Tianjin Fantasia Investment Company Limited*	The PRC 12 June 2006	RMB10,000,000	100%	100%	Property development	Limited liability company
成都通和置業有限公司 Chengdu Tonghe Real Estate Company Limited*	The PRC 18 October 2001	RMB75,610,000	100%	100%	Property development and investment	Limited liability company

#### 46. Particulars of Principal Subsidiaries of the Company (continued)

Name of subsidiary	Place and date of incorporation/ establishment	Issued and fully paid share/ registered capital	Proportion ownership interest held by the Group		Principal activities	Legal form
			2011	2010		
深圳市花千里房地產開發有限公司 Shenzhen Huaqianli Real Estate Investment Development Company Limited*	The PRC 28 August 2006	RMB660,339,487	100%	100%	Investment holding	Limited liability company
深圳置富房地產開發有限公司 Shenzhen Zhifu Real Estate Investment Development Company Limited*	The PRC 1 July 1994	RMB946,843,500	100%	100%	Property development and investment	Limited liability company
深圳宏威裝飾設計工程有限公司 Shenzhen Hongwei Decoration & Designing Company Limited*	The PRC 25 May 1994	RMB10,000,000	100%	100%	Provision of interior design services	Limited liability company
深圳市彩生活物業管理有限公司 Shenzhen Colour Life Property Management Company Limited**	The PRC 11 December 2000	RMB5,000,000	100%	100%	Provision of property operation services	Limited liability company
深圳市彩生活網絡服務有限公司 Shenzhen Colour Life Network Services Company Limited**	The PRC 12 June 2007	RMB10,000,000	100%	100%	Provision of property operation services	Limited liability company
深圳市開元同濟樓宇科技有限公司 Shenzhen Kaiyuan Tongji Building Science & Technology Company Limited**	The PRC 15 November 2001	RMB5,000,000	100%	100%	Provision of security system design, installation and maintenance services	Limited liability company
深圳市蓮塘物業管理有限公司 Shenzhen Liantang Property Management Company Limited**	The PRC 16 November 1999	RMB5,500,000	100%	100%	Provision of property operation services	Limited liability company
花樣年實業發展(成都)有限公司 Fantasia (Chengdu) Development Company Limited*	The PRC 4 July 2001	RMB50,000,000	100%	90%	Property development and investment	Limited liability company
花樣年(成都)生態旅遊開發有限公司 Fantasia (Chengdu) Ecological Tourism Development Company Limited*	The PRC 7 September 2006	RMB1,344,970,000	100%	100%	Property development	Limited liability company

## NOTES TO THE CONSOLIDATED FINANCIAL STATEMENTS

For the year ended 31 December 2011

### 46. Particulars of Principal Subsidiaries of the Company (continued)

Name of subsidiary	Place and date of incorporation/ establishment	Issued and fully paid share/ registered capital	Proportion ownership interest held by the Group		Principal activities	Legal form
			2011	2010		
成都花萬里置業有限公司 Chengdu Huawanli Real Estate Company Limited*	The PRC 25 October 2005	RMB100,000,000	100%	100%	Property development and investment	Limited liability company
成都花千里置業有限公司 Chengdu Huaqianli Real Estate Company Limited*	The PRC 6 November 2006	RMB704,680,000	100%	100%	Property development	Limited liability company
成都花百里置業有限公司 Chengdu Huabaili Real Estate Company Limited*	The PRC 22 May 2003	RMB270,000,000	100%	100%	Property development	Limited liability company
東莞市花樣年房地產投資有限公司 Dongguan Fantasia Real Estate Investment Company Limited*	The PRC 4 December 2006	RMB30,000,000	100%	100%	Property development	Limited liability company
雅浩科技發展(深圳)有限公司 Yahao Technology Development (Shenzhen) Company Limited**	The PRC 25 August 2005	HKD1,000,000	70%	100%	Investment holding	Limited liability company
深圳市康年科技有限公司 Shenzhen Kangnian Technology Company Limited*	The PRC 9 February 2007	RMB87,250,000	100%	100%	Property development and investment	Limited liability company
四川西美投資有限公司 Sichuan Ximei Investment Company Limited*	The PRC 7 June 2004	RMB500,000,000	100%	100%	Property development	Limited liability company
天津福大房地產銷售有限公司 Tianjin Fuda Real Estate Development Company Limited*	The PRC 18 October 2004	RMB45,000,000	100%	100%	Property development	Limited liability company
宜興市江南水鄉度假村有限公司 Yixing Jiangnan Shuixiang Tourism Resort Company Limited*	The PRC 19 April 2005	RMB28,000,000	60%	60%	Property development	Limited liability company
深圳市星彥行置業有限公司 Shenzhen Xingyanhang Property Company Limited**	The PRC 23 April 2007	RMB4,000,000	92.65%	92.65%	Provision of agency services	Limited liability company

#### 46. Particulars of Principal Subsidiaries of the Company (continued)

Name of subsidiary	Place and date of incorporation/ establishment	Issued and fully paid share/ registered capital	Proportion ownership interest held by the Group		Principal activities	Legal form
			2011	2010		
成都新津友幫房地產開發 有限責任公司 Chengdu Xinjin Youbang Real Estate Development Company Limited*	The PRC 9 May 2004	RMB85,000,000	100%	100%	Property development	Limited liability company
成都花樣年望叢文化發展有限公司 Chengdu Fantasia Wangcong Culture Development Company Limited*	The PRC 6 August 2008	RMB300,000,000	100%	100%	Property development	Limited liability company
成都九蓉房地產開發有限公司 Chengdu Jiurong Real Estate Development Limited*	The PRC 22 August 2007	RMB320,000,000	100%	100%	Property development	Limited liability company
深圳花樣年商業管理有限公司 Shenzhen Fantasia Business Management Company Limited*	The PRC 3 June 2009	RMB100,000,000	100%	100%	Provision of property operation services	Limited liability company
深圳市花樣年酒店管理有限公司 Shenzhen Fantasia Hotel Management Company Limited*	The PRC 3 June 2009	RMB50,000,000	100%	100%	Hotel services	Limited liability company
深圳市彩悅酒店管理有限公司 Shenzhen Caiyue Hotel Management Company Limited**	The PRC 20 August 2008	RMB100,000	100%	100%	Hotel services	Limited liability company
深圳市彩悅酒店有限公司 Shenzhen Caiyue Hotel Company Limited**	The PRC 15 January 2009	RMB100,000	100%	100%	Hotel services	Limited liability company
寧夏回族自治區新聖基建築工程 有限公司 Ningxia Hui Nationality Autonomous Region Xingshengji Construction Company Limited*	The PRC 22 July 2009	RMB20,000,000	100%	100%	Provision of construction services	Limited liability company
深圳滙恒置業有限公司 Shenzhen Huiheng Property Company Limited*	The PRC 20 April 2006	RMB10,000,000	100%	100%	Property development	Limited liability company

## NOTES TO THE CONSOLIDATED FINANCIAL STATEMENTS

For the year ended 31 December 2011

### 46. Particulars of Principal Subsidiaries of the Company (continued)

Name of subsidiary	Place and date of incorporation/ establishment	Issued and fully paid share/ registered capital	Proportion ownership interest held by the Group		Principal activities	Legal form
			2011	2010		
惠州市惠陽區花千里實業有限公司 Huizhou Huiyang Huaqianli Industry Company Limited.*	The PRC 14 August 2010	RMB100,000,000	100%	100%	Property development	Limited liability company
花千里投資(北京)有限公司 Huaqianli Investment (Beijing) Company Limited.*	The PRC 15 March 2010	RMB10,00,000	100%	76%	Investment Holding	Limited liability company
蘇州花萬里房地產開發有限公司 Suzhou Huawanli Real Estate Company Limited*	The PRC 9 September 2009	RMB180,000,000	100%	100%	Property development	Limited liability company
蘇州林甲岩房產發展有限公司 Suzhou LKN Real Estate Company Limited*	The PRC 5 July 1994	RMB180,599,652	100%	100%	Property development	Limited liability company
深圳市匯港物業管理有限公司 Shenzhen Hui Gang Property Management Company Limited**	The PRC 12 April 2002	RMB3,000,000	75%	75%	Provision of property operation services	Limited liability company
成都市花樣年物業服務有限公司 Chengdu Fantasia Property Service Company Limited*	The PRC 23 December 2009	RMB5,000,000	100%	70%	Provision of property operation services	Limited liability company
東莞花千里房地產開發有限公司 Dongguan Huaqianli Property Development Company Limited*	The PRC 30 April 2010	RMB30,000,000	100%	100%	Property development	Limited liability company
深圳高華投資有限公司 Shenzhen Gaohua Investment Limited*	The PRC 12 March 2010	RMB200,000,000	100%	100%	Investment holding, property development and investment	Limited liability company
成都市諾亞舟實業有限公司 Chengdu Nuoyazhou Development Company Limited*	The PRC 17 June 2008	RMB300,000,000	100%	100%	Property development	Limited liability company
江蘇東發置業有限公司 Jiangsu Dongfa Real Estate Company Limited*	The PRC 2 March 2009	RMB20,000,000	100%	100%	Property development	Limited liability company



#### 46. Particulars of Principal Subsidiaries of the Company (continued)

Name of subsidiary	Place and date of incorporation/ establishment	Issued and fully paid share/ registered capital	Proportion ownership interest held by the Group		Principal activities	Legal form
			2011	2010		
桂林萬豪房地產開發有限公司 Guilin Wanhao Property Development Limited*	The PRC 14 November 2007	RMB250,000,000	100%	100%	Property development	Limited liability company
桂林聚豪房地產開發有限公司 Guilin Juhao Property Development Limited*	The PRC 14 November 2007	RMB250,000,000	100%	100%	Property development	Limited liability company
成都花港置業有限公司 Chendu Huagang Real Estate Company Limited*	The PRC 14 April 2011	RMB200,000,000	100%	N/A	Property development	Limited liability company
TCL王牌電子(深圳)有限公司 TCL King Electronics (Shenzhen) Company Limited*	The PRC 9 October 1981	HKD100,000,000	100%	–	Property development	Limited liability company
惠州市友鄰物業管理有限公司 Huizhou Youling Property Management Company Limited**^	The PRC 13 June 2008	RMB500,000	100%	–	Provision of property operation services	Limited liability company
天津新塘物業管理有限公司 Tianjing Xintang Property Management Company Limited**^	The PRC 21 May 2007	RMB500,000	100%	–	Provision of property operation services	Limited liability company
深圳市羅伯特管家物業管理有限公司 Shenzhen Robert Housekeeper Property Management Company Limited**^	The PRC 9 April 2002	RMB1,000,000	51%	–	Provision of property operation services	Limited liability company

\* The English name is for identification purpose only.

# These subsidiaries were held by a non-wholly owned subsidiary of the Company namely Colour Life Services at 31 December 2011.

^ These subsidiaries were acquired during the year ended 31 December 2011. Details are set out in note 38 (b).

The above table lists the subsidiaries of the Group which, in the opinion of the directors, principally affected the results or assets of the Group. To give details of other subsidiaries would, in the opinion of the directors, result in particulars of excessive length.

## NOTES TO THE CONSOLIDATED FINANCIAL STATEMENTS

For the year ended 31 December 2011

### 47. Information about the Statement of Financial Position of the Company

Information about the statement of financial position of the Company at the end of the reporting period includes:

	2011 RMB'000	2010 RMB'000
<b>NON-CURRENT ASSETS</b>		
Investments in subsidiaries	932,758	529,525
Advances to subsidiaries	3,475,509	3,821,106
	4,408,267	4,350,631
<b>CURRENT ASSET</b>		
Banks balances and cash	49,229	101,463
<b>CURRENT LIABILITIES</b>		
Amounts due to subsidiaries	417,478	383
Accruals	4,364	5,404
Borrowings	–	662,270
	421,842	668,057
<b>NET CURRENT LIABILITIES</b>	<b>(372,613)</b>	<b>(566,594)</b>
<b>TOTAL ASSETS LESS CURRENT LIABILITIES</b>	<b>4,035,654</b>	<b>3,784,037</b>
<b>NON-CURRENT LIABILITY</b>		
Senior notes	752,367	787,330
	3,283,287	2,996,707
<b>CAPITAL AND RESERVES</b>		
Share capital (see note (37))	457,093	429,389
Reserves	2,826,194	2,567,318
	3,283,287	2,996,707

## REGISTERED OFFICES

Registered Office	Place of Business in Hong Kong
<b>Fantasia Holdings Group Co., Limited</b> Cricket Square Hutchins Drive P.O. Box 2681 Grand Cayman, KY1-1111 Cayman Islands	<b>Fantasia Holdings Group Co., Limited</b> Room 1103, Top Glory Tower 262 Gloucester Road Causeway Bay Hong Kong

## TRUSTEE

**Citicorp International Limited**  
56/F, One Island East  
18 Westlands Road  
Island East  
Hong Kong

## PAYING AGENT, NOTE REGISTRAR AND CMU LODGING AGENT

**Citicorp International Limited**  
9/F Two Harbourfront  
22 Tak Fung Street  
Hunghom  
Hong Kong

## LEGAL ADVISORS TO THE COMPANY

*As to U.S. and Hong Kong Law*

**Sidley Austin**  
Level 39, Two International  
Finance Centre  
8 Finance Street  
Central, Hong Kong

*As to Cayman Islands Law*

**Conyers Dill & Pearman  
(Cayman) Limited**  
Cricket Square  
Hutchins Drive  
P.O. Box 2681  
Grand Cayman, KY1-1111  
Cayman Islands

*As to British Virgin Islands Law*

**Conyers Dill & Pearman**  
Commerce House  
Wickhams Cay 1  
P.O. Box 3140, Road Town  
Tortola  
British Virgin Islands VG1110

*As to PRC Law*

**Commerce & Finance Law  
Offices**  
6N NCI Tower, A12  
Jianguomenwai Avenue  
Beijing 100022, PRC

## LEGAL ADVISORS TO THE INITIAL PURCHASERS

*As to U.S. Law*

**Davis Polk & Wardwell**  
18th Floor  
The Hong Kong Club Building  
3A Chater Road  
Central, Hong Kong

*As to PRC Law*

**King & Wood Mallesons**  
28th Floor, Landmark  
4028 Jintian Road, Futian District  
Shenzhen, PRC

## INDEPENDENT ACCOUNTANTS

**Deloitte Touche Tohmatsu**  
35/F, Pacific Place One  
88 Queensway  
Hong Kong